

TECNOLEC

TECWD85AD

LAVE LINGE SÉCHANT
WAS-EN DROOGCOMBINATIE
SECADOR DA MÁQUINA DE LAVAR
LAVASCIUGA BIANCHERIA
WASHER DRYER



 MANUEL D'UTILISATION

 HANDLEIDING

 MANUAL DE INSTRUÇÕES

 MANUALE DI ISTRUZIONI

 OPERATING INSTRUCTIONS

Table des matières

MISES EN GARDE IMPORTANTES	1
DESCRIPTION DU PRODUIT	5
INSTALLATION.....	8
AVANT CHAQUE LAVAGE	11
LAVAGE ET SÉCHAGE	13
TABLEAU DES PROGRAMMES	18
FONCTIONS SUPPLÉMENTAIRES	20
Fonction de Départ Différé	20
Fonction Sonore.....	20
Verrouillage Sécurité-enfant.....	21
NETTOYAGE ET ENTRETIEN	21
GUIDE DE DÉPANNAGE	24
FICHE D'INFORMATION SUR LE PRODUIT	26
SERVICE DE RÉPARATION ET PIÈCES DE RECHANGE	32
MISE AU REBUT.....	33

Ce produit a été fabriqué et vendu sous la responsabilité des Etablissements Darty et Fils (S.A.S).
et le logo sont des marques utilisées sous licence par les
Etablissements Darty et Fils (S.A.S) – pour plus d'informations : www.brand.com.
Tous autres produits, services, dénominations sociales, marques, nom commerciaux, noms
de produits et logos référencés ici sont la propriété de leurs titulaires respectifs.

MISES EN GARDE IMPORTANTES

MERCI DE BIEN VOULOIR LIRE LES CONSIGNES DE SÉCURITÉ ATTENTIVEMENT AVANT D'UTILISER L'APPAREIL ET DE LES CONSERVER POUR RÉFÉRENCE ULTÉRIEURE.

Attention

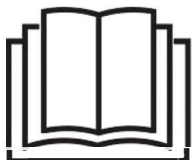

- **Lisez la notice d'utilisation.**
- **Cet appareil est destiné à être utilisé dans des applications domestiques et analogues, tels que:**
 - **des coins-cuisine réservés au personnel dans des magasins, bureaux et autres environnements professionnels;**
 - **des fermes;**
 - **par les clients des hôtels, motels et autres environnements à caractère résidentiel;**
 - **des environnements du type chambres d'hôtes;**
 - **des emplacements prévus pour un usage collectif dans des immeubles d'habitation.**
- **Si le câble d'alimentation est endommagé, il doit être remplacé par le fabricant, son service après vente ou des personnes de qualification similaire afin d'éviter un danger.**
- **Cet appareil peut être utilisé par des enfants âgés d'au moins 8 ans et par des personnes ayant des capacités physiques, sensorielles ou mentales réduites ou dénuées d'expérience ou de connaissance, s'ils (si elles) sont correctement surveillé(e)s ou si des instructions relatives à l'utilisation de l'appareil en toute sécurité leur ont été données et si les risques encourus ont été appréhendés.**
Les enfants ne doivent pas jouer avec l'appareil.

Le nettoyage et l'entretien par l'utilisateur ne doivent pas être effectués par des enfants sans surveillance.

- **ATTENTION: Ne pas raccorder à une alimentation en eau chaude.**
- **Les ouvertures d'aération ne doivent pas être obstruées par un tapis.**
- **La pression de l'eau à l'entrée ne doit pas être inférieure à 0.1 MPa ni supérieure à 1 MPa.**

- **Les ensembles de raccordement neufs fournis avec l'appareil doivent être utilisés; il convient de ne pas réutiliser les ensembles de raccordement usagés.**
- **Il convient de maintenir à distance les enfants de moins de 3 ans, à moins qu'ils ne soient sous une surveillance continue.**
- **En ce qui concerne la méthode du nettoyage, référez-vous à la section "NETTOYAGE ET ENTRETIEN" en pages 21-23.**
- **La masse maximale de linge sec, en kilogrammes, pour cet appareil est de 8 kg (pour le cycle "lavage") et 5 kg (pour le cycle "lavage et séchage").**
- **Le sèche-linge à tambour ne doit pas être utilisé si des produits chimiques ont été utilisés pour le nettoyage.**
- **Le collecteur de bourre doit être nettoyé fréquemment.**
- **Il ne faut pas laisser de la bourre s'accumuler autour du sèche-linge à tambour.**
- **Une ventilation appropriée doit être fournie afin d'éviter un refoulement, à l'intérieur de la pièce, de gaz provenant d'appareils brûlant d'autres combustibles, y compris les feux ouverts.**
- **Ne pas sécher dans le sèche-linge à tambour des articles non lavés.**
- **Il convient que les articles qui ont été salis avec des substances telles que l'huile de cuisson, l'acétone, l'alcool, l'essence, le kérosène, les détachants, la**

térébenthine, la cire et les substances pour retirer la cire soient lavés dans de l'eau chaude avec une quantité supplémentaire de détergent avant d'être séchés dans le sèche-linge à tambour.

- Il convient que les articles comme le caoutchouc mousse (mousse de latex), les bonnets de douche, les textiles étanches, les articles doublés de caoutchouc et les vêtements ou les oreillers comprenant des parties en caoutchouc mousse ne soient pas séchés dans le sèche-linge à tambour.
- Il convient d'utiliser les produits assouplissants, ou produits similaires, conformément aux instructions relatives aux produits assouplissants.
- Retirer des poches tous les objets tels que briquets et allumettes.
- **MISE EN GARDE:** Ne jamais arrêter un sèche-linge à tambour avant la fin du cycle de séchage, à moins que tous les articles ne soient retirés rapidement et étalés, de telle sorte que la chaleur soit dissipée.
- **MISE EN GARDE:** L'appareil ne doit pas être alimenté par l'intermédiaire d'un interrupteur externe, comme une minuterie, ou être connecté à un circuit qui est régulièrement mis sous tension et hors tension par le fournisseur d'électricité.
- L'air rejeté ne doit pas être évacué dans une évacuation utilisée pour les fumées rejetées provenant des appareils brûlant du gaz ou d'autres combustibles.
- L'appareil ne doit pas être installé derrière une porte à verrouillage, une porte coulissante ou une porte ayant une charnière du côté opposé à celle du sèche-linge,
- empêchant ainsi l'ouverture totale du sèche-linge à tambour.

Précautions de sécurité

- L'appareil est conçu exclusivement pour une utilisation à

l'intérieur.

- **Gardez les matériaux d'emballage de l'appareil hors de portée des enfants pour éviter tout risque de danger.**
- **Ne branchez pas la machine à l'alimentation si vos mains sont mouillées.**
- **Ne touchez pas la machine avec les mains ou les pieds mouillés.**
- **En cas de panne de courant, débranchez tout d'abord la machine de l'alimentation et fermez le robinet d'eau. N'essayez pas de réparer la machine vous-même. Veuillez contacter un technicien agréé.**
- **Ne dépassez jamais la capacité de charge maximale.**
- **La porte en verre peut devenir très chaude durant le cycle de lavage. Gardez les enfants et les animaux domestiques éloignés de la machine durant son utilisation.**
- **Ne forcez jamais l'ouverture de la porte lorsque la machine est en cours de fonctionnement.**
- **Ne laissez pas les enfants sans surveillance près de la machine, car ils pourraient s'enfermer à l'intérieur.**
- **Débranchez toujours la machine de l'alimentation électrique après son utilisation.**
- **Les animaux et les enfants risquent de monter dans la machine. Vérifiez l'appareil avant chaque opération.**
- **La prise doit être facilement accessible après l'installation de l'appareil.**
- **Ne lavez pas d'articles qui ont été nettoyés, trempés ou tamponnés avec des substances combustibles ou explosives (telles que de la cire, de l'huile, de la peinture, de l'essence, des dégraissants, des solvants de nettoyage à sec, du kérosène, etc.). Cela peut provoquer un incendie ou une explosion.**
- **La machine ne doit pas être installée dans une salle de bain ou dans des pièces très humides, ni dans des pièces contenant des gaz explosifs ou caustiques.**

DESCRIPTION DU PRODUIT

Tiroir
(pour détergent
et adoucissant)

Panneau de contrôle

Porte

Tambour

Couvercle du filtre
de vidange

Pieds réglables (4)



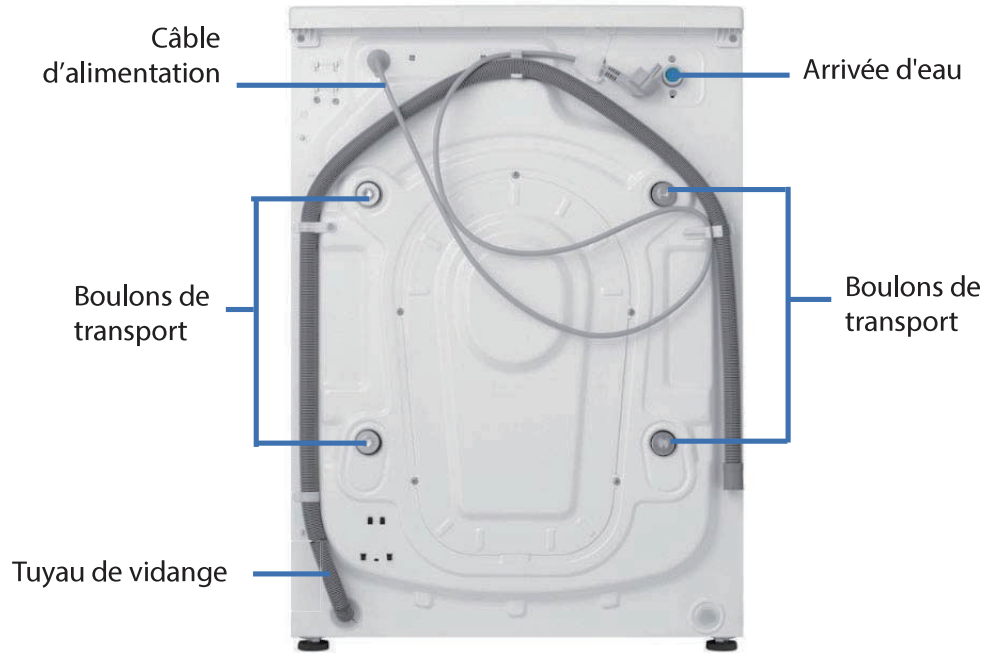

Accessoires



Capuchons



Tuyau d'arrivée d'eau



Plaque inférieure



Coude en U



Clé

Panneau de contrôle

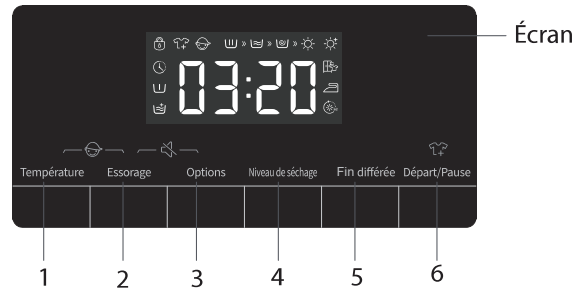
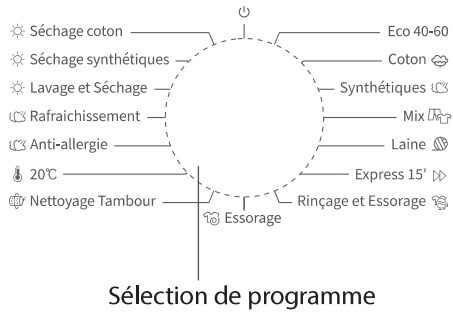

- 1 Bouton de sélection de la température
- 2 Bouton d'essorage
- 3 Bouton des options
- 4 Bouton de niveau de séchage
- 5 Bouton d'arrêt différé
- 6 Bouton Départ/Pause

- 1 + 2 Verrouillage sécurité-enfant
- 2 + 3 Fonction sonore
- 6 Fonction recharge

Indicateurs sur l'écran

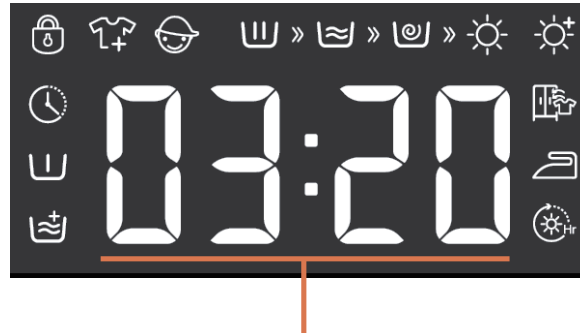

Indique la durée du lavage, la Vitesse, le code d'erreur ou la température

Verrouillage de la porte	Recharge	Verrouillage Sécurité-enfants	Arrêt différé	Prélavage	Rinçage supplémentaire

Symboles de niveau de séchage

Séchage supplémentaire	Sec pour placard	Prêt à repasser	Séchage minuté

Les symboles apparaissent à l'écran lorsque la phase correspondante est réglée.



INSTALLATION

■ Retrait de l'emballage

1. Retirez le carton et l'emballage en polystyrène.
2. Soulevez le lave-linge et enlevez l'emballage de la base. Cette manipulation nécessite au moins 2 personnes.
3. Enlevez le ruban de fixation du cordon d'alimentation électrique et du tuyau de vidange.



AVERTISSEMENT :

Les éléments d'emballage (tels que les films, le polystyrène) peuvent être dangereux pour les enfants.

Risque d'étouffement ! **Veillez à ce que tous les éléments d'emballage restent hors de portée des enfants.**

■ Retrait des boulons de transport

L'appareil est équipé de boulons de transport pour éviter les dommages internes pendant le transport. L'emballage et tous les boulons de transport doivent être enlevés avant d'utiliser l'appareil.

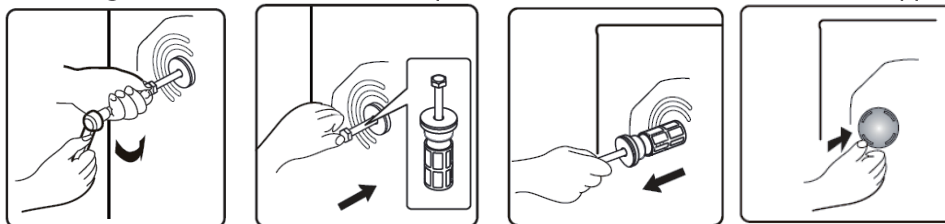

1. Utilisez une clé pour faire tourner les têtes de boulons dans le sens contraire aux aiguilles d'une montre jusqu'à ce que les boulons puissent être partiellement retirés.
2. Poussez les boulons de transport vers l'intérieur pour les desserrer.
3. Retirez les boulons de transport et les bagues en caoutchouc en tirant vers l'extérieur.
4. Fermez les trous avec les bouchons fournis.

■ Positionnement

Installez la machine sur un sol plat et ferme.
Veillez à ce que la circulation de l'air autour de l'appareil ne soit jamais entravée par des tapis, moquettes etc.
Prévoyez au moins 2 cm d'espace libre de chaque côté de l'appareil.
Veillez à ce que l'appareil ne repose pas sur son propre câble d'alimentation.

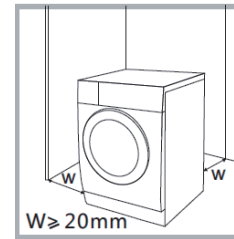

■ Exigences relatives à l'emplacement d'installation

Avant d'installer le lave-linge, un emplacement approprié comme suit doit être sélectionné :

- Une surface ferme, sèche et plane.
- Évitez la lumière directe du soleil
- Une ventilation suffisante
- La température ambiante est supérieure à 0° C.
- L'appareil doit être installé à distance de toute source de chaleur (appareils brûlant du gaz ou du charbon etc.).

■ Mise à niveau du sèche-linge

Un nivellement correct de la machine permet d'éviter les bruits et les vibrations excessifs.
Installez l'appareil sur une surface plane et solide au sol.

Si le sol est irrégulier, ajustez les pieds réglables au besoin.

- Ne mettez en aucun cas des objets sous les pieds de l'appareil (morceaux de carton, blocs de bois etc.).

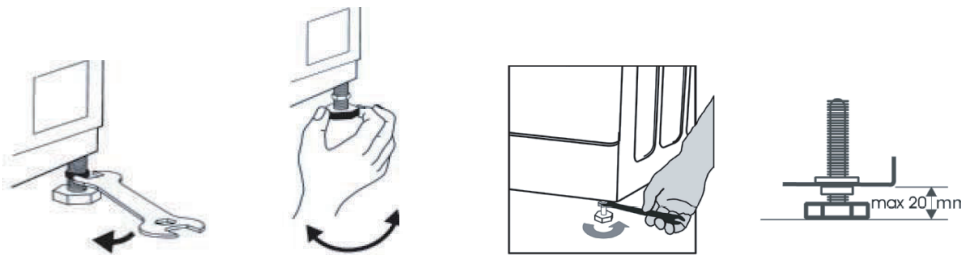

1. Dévissez les contre-écrous avec une clé.
2. Ajustez la hauteur en tournant les pieds réglables.
 - Veillez à ce que les 4 pieds touchent bien le sol, puis vérifiez que l'appareil est nivelé correctement en utilisant un niveau à bulle.
3. Serrez les contre-écrous.

■ Installation du capot inférieur

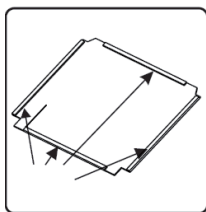

1. Retirez la feuille de protection du ruban adhésif double face collé aux quatre coins de la plaque inférieure.

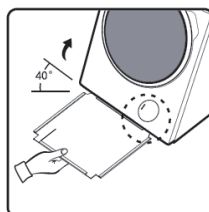

2. Inclinez l'appareil vers l'arrière (angle d'inclinaison : 40°) et insérez la plaque inférieure.

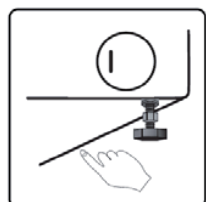

3. Pressez le ruban adhésif double face pour fixer la plaque inférieure à l'appareil.

Attention : Afin d'obtenir de meilleures performances en matière de niveau sonore, assurez-vous de placer la « plaque inférieure de réduction du bruit » comme indiqué. Veuillez lire et suivre les instructions d'installation figurant sur la plaque de réduction du bruit et dans le manuel d'instructions.

■ Connexion électrique

Votre sèche-linge fonctionne avec un courant de 220-240 V et 50Hz.

Les branchements électriques doivent être réalisés par un technicien qualifié en conformité avec les réglementations de sécurité locales.

Votre lave-linge doit être correctement relié à la terre. Nous ne serons pas responsables des dommages se produisant à cause de l'utilisation de la machine sans connexion correcte à la terre.

N'utilisez pas de rallonge ni de prise multiple.

L'appareil ne doit pas être branché par l'intermédiaire d'un appareil temporisateur externe (minuteur etc.) ou raccordé à un circuit qui l'allume et l'éteint par intermittence.

Ne débranchez pas l'appareil s'il y a du gaz inflammable à proximité.

■ Raccordement des tuyaux

Raccordement du tuyau d'arrivée d'eau



La machine doit être connectée à une alimentation en eau froide.

Assurez-vous que le tuyau n'est pas plié et qu'il n'est pas écrasé.

1. Vissez une extrémité du tuyau d'arrivée d'eau à l'arrière de la machine.

2. Connectez l'autre extrémité du tuyau d'arrivée d'eau à un robinet à raccord fileté 3/4".

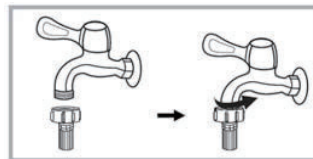
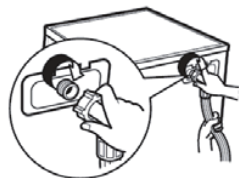

REMARQUE :

Une fois le raccordement terminé, ouvrez lentement le robinet et assurez-vous qu'il n'y a pas de fuite.

Veillez à ce que le tuyau ne soit pas tordu, écrasé, modifié ou sectionné.

Raccordement du tuyau de vidange

Pour installer le tuyau de vidange, veuillez utiliser l'une des méthodes suivantes.

Assurez-vous que le tuyau de vidange de l'eau ne soit pas plié, tordu, écrasé ou étiré.

- Insérez fermement le tuyau de vidange dans la colonne d'évacuation.

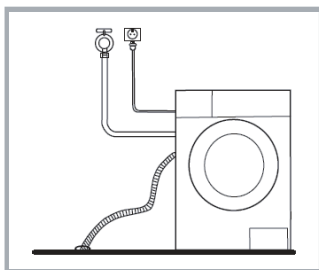

- Lorsque vous installez le tuyau de vidange dans un évier, fixez-le fermement avec une corde.

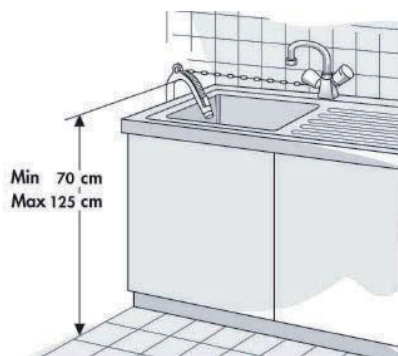

REMARQUE :

Le tuyau de vidange de l'eau doit être monté à une hauteur comprise entre 70 cm et 125 par rapport au sol.

AVANT CHAQUE LAVAGE

Règles de séparation du linge

- Type de tissu / symbole sur l'étiquette de lavage (coton, fibres mélangées, synthétique, laine, vêtements à laver à la main)
- Couleur
Séparez les articles en couleur des articles blancs. Lavez les vêtements neufs de couleur séparément.
- Dimensions
Lavez les articles de différentes tailles dans la même charge pour améliorer l'efficacité du lavage et la répartition des articles dans le tambour.
- Tissus délicats
Lavez les articles délicats séparément.
- Les articles pour bébés (vêtements de bébé, serviettes et mouchoirs) doivent être lavés séparément. S'ils sont lavés avec les vêtements des adultes, ils peuvent être infectés. La durée de rinçage sera augmentée pour assurer que le rinçage complet et le nettoyage ne laisse aucun résidu de lessive.
- Il est recommandé que les éléments qui sont facilement tachés tels que des chaussettes, des manches, des cols blancs etc., soient lavés à la main avant d'être mis dans le lave-linge pour obtenir des effets de lavage plus performants.

Poches vides



Assurez-vous que toutes les poches sont vides. Des objets tels que des clous, des pinces à cheveux, des allumettes, des stylos, des pièces de monnaie et des clés peuvent endommager votre machine et vos vêtements.

Fermez toutes les fermetures à glissière, boutons et crochets.

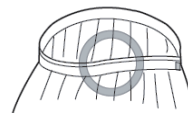

Fermez les fermetures à glissière, les crochets et les ficelles pour vous assurer que ces articles ne se coincent pas dans d'autres vêtements.

Nouez tous les rubans ou ceintures.

Détergent

Reportez-vous aux instructions figurant sur le paquet de détergent ou autre produit pour connaître le dosage correct en fonction de la quantité de linge, du degré de salissure et de la dureté de l'eau.

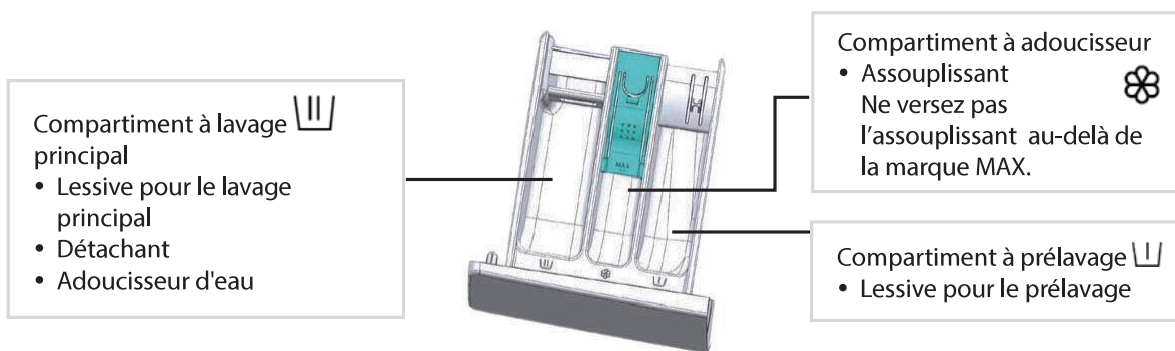

Le choix de la lessive dépend du (de la) :

- type de tissu (coton, facile d'entretien / tissus synthétiques, articles délicats, laine).
Remarque : Utilisez uniquement des lessives spécifiques pour le lavage de la laine.
- Couleur
- Température de lavage
- Degré et type de salissure

Remarques :

- Les résidus blanchâtres sur les tissus foncés sont causés par des composés insolubles utilisés dans les lessives modernes en poudre sans phosphate. Si cela se produit, secouez ou brossez le tissu ou utilisez des lessives liquides.
- Utilisez uniquement des lessives et adoucissants spécifiquement conçus pour les lave-linges domestiques.
- Lorsque vous utilisez des agents de détartrage, des colorants ou des agents de blanchiment pour le prélavage, assurez-vous qu'ils conviennent aux lave-linges domestiques. Les détartrants peuvent contenir des produits susceptibles d'endommager votre lave-linge.
- N'utilisez pas de solvant (par exemple de la térébenthine, du benzène). Ne lavez pas en machine les tissus qui ont été traités avec des solvants ou des liquides inflammables.
- Gardez les lessives et les additifs dans un endroit sûr et sec, hors de la portée des enfants.
- Pour éviter tout problème de dosage lors de l'utilisation de lessives en poudre et liquide très concentrées, utilisez la boule ou le sac spécial fourni avec la lessive et placez-le directement à l'intérieur du tambour.

LAVAGE ET SÉCHAGE

Avant le premier cycle de lavage

Pour éliminer toute eau résiduelle laissée lors des tests par le fabricant, il est recommandé d'effectuer un cycle de lavage court sans linge.

1. Ouvrez l'eau du robinet.
2. Fermez la porte.
3. Versez une petite quantité de lessive dans le compartiment à lessive liquide / poudre à dosage manuel pour la phase de lavage.
4. Sélectionnez et démarrez un programme court.

Lavage et séchage du linge

1. Ouvrez la porte et chargez les articles à laver dans le tambour.



NE SURCHARGEZ PAS la machine.
Respectez les charges indiquées dans le tableau des programmes.
Une surcharge de linge entraînera de pauvres résultats de lavage.

2. Fermez la porte.

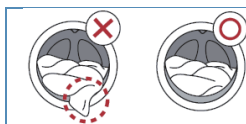

Assurez-vous qu'aucun linge ne se coince entre la porte et le joint de la porte.

3. Ajoutez la lessive et l'adoucissant.

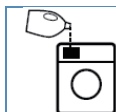

Ouvrez le tiroir.
Ajoutez la lessive et l'adoucissant dans les compartiments correspondants.
Ne les faites pas déborder.

4. Activez l'alimentation en eau.

5. Sélectionnez le programme souhaité.

Tournez le bouton de sélection du programme pour sélectionner le programme désiré.
L'écran affichera la durée de lavage.



Le sélecteur sert également à allumer et éteindre la machine.

Pour un aperçu détaillé des programmes, reportez-vous au Tableau des programmes.

6. Modifiez le réglage de température, si nécessaire.

Appuyez plusieurs fois sur **Température** jusqu'à ce que la température désirée s'affiche à l'écran.





7. Modifiez la vitesse d'essorage, si nécessaire.

Appuyez plusieurs fois sur **Essorage** pour sélectionner la vitesse d'essorage désirée.

8. Sélectionnez les options, si nécessaire.

Appuyez plusieurs fois sur **Options** pour sélectionner l'option désirée. Les options ne sont disponibles que lorsque certains programmes sont sélectionnés.

L'écran affichera le symbole correspondant lors de la sélection de l'option.

<p> Prélavage</p> <p>Sélectionnez cette option pour laver du linge très sale. Avant le lavage, le détergent à lessive / la lessive en poudre peuvent être ajoutés au compartiment de prélavage et la lessive en poudre doit être ajoutée au compartiment de lavage principal.</p>	
<p> Rinçage Supplémentaire</p> <p>Sélectionnez cette option pour ajouter un cycle de rinçage supplémentaire afin d'obtenir un meilleur résultat de rinçage.</p>	

9. Sélectionnez le niveau de séchage souhaité.

Appuyez plusieurs fois **Niveau de séchage** pour sélectionner le niveau de séchage souhaité et l'écran affiche le symbole du niveau défini:

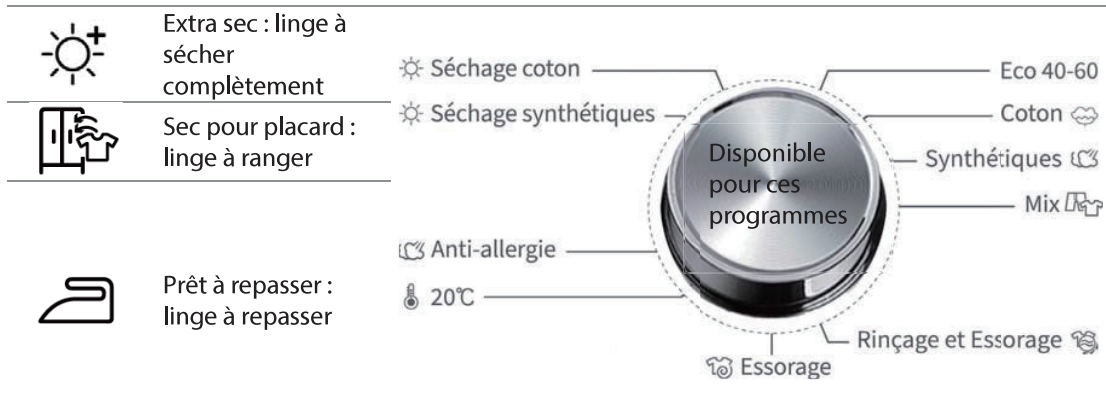

Le lave-linge peut détecter le poids des vêtements pour ajuster automatiquement le temps de séchage.

Avant le séchage, veuillez confirmer si les vêtements peuvent être séchés.

Vêtements non lavables •secs / non secs

Vêtements qui ne peuvent être ni lavés ni séchés



Produits en cuir et en fourrure
(Des déformations peuvent être causées).



Rayonne et ses produits mélangés
(Une décoloration ou une déformation peut être causée).

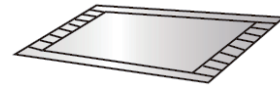

Gros coussins en caoutchouc épais avec du carbamate au dos.
(Des dommages ou des déformations peuvent être causés).



Chapeaux avec un matériau dur
(Cela endommagera la machine et causera des défauts.)



Coussins, oreillers, articles avec ouate mousse et autres matériaux spongieux, housse de tapis.
(Des dommages ou des déformations peuvent être causés).

Autres :
Vêtements froissés ou gaufrés ; tissus crêpés ;
Vêtements facilement déformables (costumes, vestes, cravates et robes, etc.) ;
Vêtements facilement pelucheux (velours, veloutine).

Vêtements qui ne peuvent pas être séchés



Tout vêtement marqué par un graphique (Les vêtements peuvent être endommagés.)



Vêtements en laine (Un rétrécissement et une perte de fourrure peuvent être causés.)



Collants, bas (Des dommages ou déformations peuvent être causés.)



Vêtements d'appoint

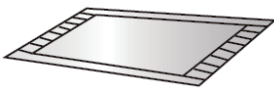

Coussins ou vêtements en fourrure (Des dommages ou des déformations peuvent être causés.)



Couette (Des dommages ou des déformations peuvent être causés.)



Vêtements avec dentelle et broderie, nouvelle fibre synthétique (fibre très fine) (Une déformation peut être causée.)



Soie

Remarque !

Les vêtements secs / non secs non lavables comprennent, mais sans s'y limiter, les vêtements ci-dessus.

Les vêtements mouillés qui dégoulinent ne sont pas adaptés au séchage, ce qui peut provoquer l'alarme de la machine !

Temps de séchage

Lorsque l'écran affiche le symbole



, appuyez de manière répétée sur **Niveau de séchage** pour régler le temps qui convient aux tissus que vous voulez faire sécher. L'écran affiche la durée réglée (30 minutes, 1 heure, 1,5 heure, 2 heures, 3 heures et 4 heures).



- Avant de sécher séparément, veuillez sortir les vêtements du tambour et les remettre dans le tambour après les avoir détachés.
- Lorsque peu de vêtements ou des vêtements légers sont séchés, le temps de séchage peut être plus

court que le temps programmé.

- Si le linge lavé à la main doit être séché, avant le séchage, sélectionnez l'essorage à grande vitesse en fonction du type de vêtement. Il est recommandé de sélectionner les programmes « Essorage + niveau de séchage ».
- À la fin du programme de séchage, la machine fonctionnera pendant un certain temps selon un certain rythme pour détendre les vêtements et réduire les plis.
- Le séchage en surcharge peut affecter l'effet de séchage, tandis que le séchage excessif peut provoquer le froissage des vêtements. Pour les vêtements en fibres chimiques, tels que les chemises, etc., il convient de sélectionner le séchage au fer .
- Si les vêtements avec différents types de tissus sont séchés ensemble, la performance de séchage peut être affectée. Il est donc recommandé de trier correctement les vêtements avant de les sécher.

10. Démarrer un programme.

Appuyez sur **Départ/Pause**. La porte se verrouille et l'écran affiche le symbole .

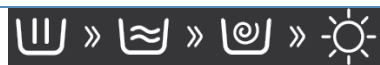



Ces symboles indiquent les phases du programme. Le symbole clignotant indique quelle phase est en cours.

Pesée automatique

L'écran affichera « --- » après le démarrage d'un programme, indiquant qu'il est en train de peser automatiquement. Il ajustera automatiquement la durée du programme (heures:minutes) en fonction du poids du linge.

11. Mettre en pause un programme en cours et ouvrir la porte, si nécessaire.

- Appuyez sur **Départ/Pause** pour mettre en pause un programme en cours d'exécution.
- Si le niveau de l'eau ou la température n'est pas trop élevée, le symbole de verrouillage de la porte  disparaîtra et l'écran affichera le symbole de recharge . Vous pouvez alors ouvrir la porte, par exemple, pour ajouter plus de linge ou pour retirer du linge chargé par erreur.
- Appuyez sur **Départ/Pause** pour poursuivre le programme.

12. Modifier un programme et les paramètres, si nécessaire.

Pour modifier les paramètres d'un programme en cours d'exécution :



- Mettez le sélecteur de programme sur la position d'arrêt  pendant environ 3 secondes.
- Sélectionnez un nouveau programme et modifiez les paramètres.
- Appuyez sur **Départ/Pause** pour démarrer le nouveau programme.

13. À la fin du cycle, l'écran affichera le message « Fin ».

14. Éteignez la machine en mettant le sélecteur de programme sur la position d'arrêt .

15. Ouvrez la porte et retirez le linge.































- La porte ne peut être ouverte que lorsque le symbole  disparaît.
- Vérifiez que le symbole  a disparu.
- Ouvrez la porte et retirez le linge.
- Laissez la porte entrouverte pour laisser l'intérieur du lave-linge sécher.



Fermez le robinet.

TABLEAU DES PROGRAMMES

Programme	Fonctions	Charge maximale (kg)	Températures	Max. Vitesse d'essorage (Tr/m)
 Séchage coton	Séchage	5	—	—
 Séchage synthétiques	Séchage	5	—	—
 Lavage et Séchage	Lavage et séchage	5	—	1400
 Rafraichissement	Séchage	2	—	—
 Anti-allergie	Lavage	4	40°C, 60°C, 90°C	1400
	Lavage et séchage	4		
 20°C	Lavage	8	20°C	1400
	Lavage et séchage	5		
 Nettoyage Tambour	Lavage et séchage	—	90°C	800
Eco 40-60	Lavage	8	—	1400
	Lavage et séchage	5		
Coton 	Lavage	8	Froid, 20°C, 30°C, 40°C, 60°C, 90°C	1400
	Lavage et séchage	5		
Synthétiques 	Lavage	8	Froid, 20°C, 30°C, 40°C, 60°C	1200
	Lavage et séchage	5		1400
Mix 	Lavage	4	Froid, 20°C, 30°C, 40°C	1400
	Lavage et séchage			
Laine 	Lavage	2	Froid, 20°C, 30°C, 40°C	600
Express 15' 	Lavage	1	Froid, 20°C, 30°C, 40°C	800
Rinçage et Essorage 	Lavage	8	—	1400
	Lavage et séchage	5		
 Essorage	Essorage	8	—	1400
	Essorage et séchage	5		

Programme	Description du programme (Type de charge et niveau du sol)	Détergents et additifs		
		Pré-lavage I	Lavage principal II	Assouplissant 
 Séchage coton	Les vêtements humides en coton et en lin peuvent être séchés après avoir été essorés.	—	—	—
 Séchage synthétiques	Les vêtements en fibres chimiques humides peuvent être séchés après avoir été essorés.	—	—	—
 Lavage et Séchage	Le cycle «lavage et séchage» convient au lavage du linge de coton normalement sale déclaré lavable à 40 °C ou 60 °C, au cours du même cycle, et au séchage de ce linge de manière à ce qu'il puisse immédiatement être rangé, et que ce programme est utilisé pour évaluer la conformité à la législation de l'Union en matière d'écoconception.	○	●	○
 Rafrachissement	Ce programme est adapté à l'élimination des odeurs particulières (telles que l'odeur de la fumée, de la marmite chaude, du barbecue, etc.) sur les vêtements.	—	—	—
 Anti-allergie	Programme d'extinction efficace des bactéries dans les textiles. Il est approprié pour les vêtements des bébés qui sont sensibles aux vêtements.	○	●	○
 20°C	Un cycle convenant au lavage du linge de coton légèrement sale, à une température nominale de 20 °C	○	●	○
 Nettoyage Tambour	Programme destiné à éliminer la saleté et les résidus bactériens qui peuvent se développer dans la machine après une certaine période d'utilisation, en particulier lorsque des lavages à basse température sont utilisés régulièrement.	—	—	—
Eco 40-60	Un cycle convenant au lavage du linge de coton normalement sale déclaré lavable à 40 °C ou 60 °C, au cours du même cycle	○	●	○
Coton 	Pour laver le coton ou le lin fortement et normalement sale Pour les vêtements très sales, sélectionnez la fonction « Prélavage ».	○	●	○
Synthétiques 	Pour les tissus synthétiques et les tissus en coton mélangé modérément sales.	○	●	○
Mix 	Pour les charges mixtes de coton et de tissus synthétiques modérément sales.	○	●	○
Laine 	Pour la laine lavable en machine. (Reportez-vous à l'étiquette de lavage apposée sur le vêtement).	○	●	○
Express 15' 	Pour laver rapidement les vêtements peu sales	○	●	○
Rinçage et Essorage 	Ce programme est défini par défaut sur deux rinçages et essorage.	—	—	○
 Essorage	Essorage supplémentaire avec vitesse d'essorage sélectionnable.	—	—	—

● = dosage requis / ○ = en option

FONCTIONS SUPPLÉMENTAIRES

■ Fonction de Départ Différé

Vous pouvez utiliser cette fonction pour que le programme se termine plus tard. L'heure de fin du délai peut être choisie entre 1 et 24 heures par incréments de 1 heure.

1. Sélectionnez un programme.
2. Appuyez plusieurs fois sur **Fin différée** pour sélectionner l'heure de fin souhaitée.
 - Les heures affichées indiquent l'heure à laquelle le programme se terminera.
 - L'écran affichera le symbole .
3. Appuyez sur **Départ/Pause** pour démarrer le programme.
 - La machine effectuera alors un compte à rebours.

Par exemple, si la durée du programme est supérieure à 2 heures, la fonction de fin de délai minimum doit démarrer à partir de 3 heures.

Si la durée du programme que vous avez sélectionné est de 2:28 heures et que vous définissez l'heure de « Fin différée » à 6 heures. Cela signifie que votre programme de lavage se terminera dans 6 heures.

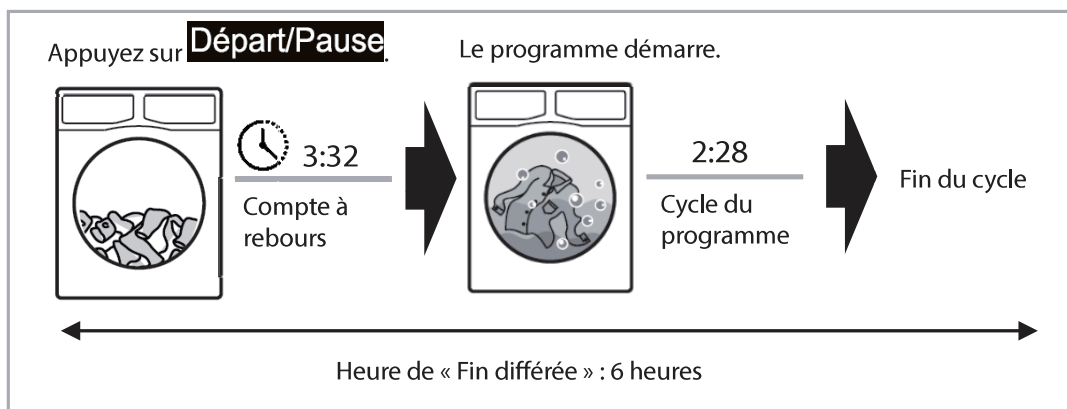

Si vous souhaitez annuler cette fonction avant de démarrer le programme, appuyez plusieurs fois sur

Fin différée jusqu'à ce que le symbole  disparaisse de l'écran.

Pour annuler cette fonction après le démarrage du programme, éteignez la machine en mettant le sélecteur de programme sur la position d'arrêt .

■ Fonction Sonore

Vous pouvez utiliser cette fonction pour activer ou désactiver le son émis lorsque vous appuyez sur les boutons ou lorsque vous tournez le bouton de sélection du programme.

- Appuyez et maintenez enfoncés simultanément les boutons **Essorage** et **Options** durant 2 secondes jusqu'à ce que "bEEp oFF" s'affiche sur l'écran, indiquant que le son est coupé.
- Pour désactiver cette fonction, appuyez et maintenez enfoncés simultanément les boutons **Essorage** et **Options** durant environ 2 secondes. "bEEp oN" s'affiche sur l'écran.

■ Verrouillage Sécurité-enfants

Pour renforcer la sécurité des enfants, cette machine est équipée d'une fonction de verrouillage enfant.

Lorsque le programme démarre, appuyez et maintenez enfoncés **Température** et **Essorage** en même temps pendant 2 secondes. L'écran affichera le symbole , indiquant que la fonction est activée.

Lorsque la fonction est activée, tous les boutons de fonction sont verrouillés.

Pour désactiver cette fonction, maintenez à nouveau enfoncés **Température** et **Essorage** pendant 2 secondes. Le symbole  disparaîtra de l'écran.

- Lorsque vous éteignez la machine en tournant le sélecteur de programme sur la position Arrêt , la fonction de sécurité enfants est désactivée.
- Une fois le programme terminé, la sécurité enfant se déverrouille automatiquement.

NETTOYAGE ET ENTRETIEN



AVERTISSEMENT :

Il est indispensable de débrancher l'appareil et de fermer le robinet avant toute manipulation de nettoyage et d'entretien.

■ Nettoyage du boîtier de la machine

Essuyez-le avec un chiffon doux légèrement imbibé d'eau.

N'utilisez pas d'agents nettoyants chimiques ou abrasifs.

Enlevez immédiatement les résidus de lessive et de produit de nettoyage.

■ Nettoyage du tambour

La rouille laissée à l'intérieur du tambour par les articles métalliques doit être enlevée immédiatement avec des détergents sans chlore. N'utilisez en aucun cas de la paille de fer pour le nettoyage du tambour !

Pour détartrer le tambour, utilisez le cycle de Nettoyage du tambour avec un produit détartrant en suivant les instructions du fabricant du produit pour le dosage.

■ Nettoyage du joint de porte et du verre

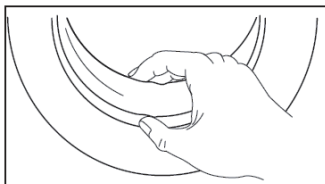

Essuyez le verre et le joint après chaque lavage pour enlever les peluches et les taches. Si des peluches s'accumulent, cela peut causer des fuites.

Retirez toutes les pièces de monnaie, boutons et autres objets du joint après chaque lavage.

Nettoyez le joint de porte et le hublot une fois par mois afin d'assurer le bon fonctionnement de la machine.

■ Nettoyage du filtre d'arrivée



REMARQUE :

Nettoyez le filtre d'arrivée d'eau si l'eau n'arrive pas normalement.

Si l'eau est très dure ou contient des traces de calcaire, il peut arriver que le filtre d'arrivée d'eau soit obstrué. Il est recommandé de nettoyer le filtre d'arrivée d'eau de temps en temps.

1. Fermez le robinet d'eau et dévissez le tuyau d'arrivée.

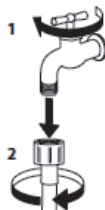

2. Nettoyez soigneusement le filtre à mailles au bout du tuyau avec une brosse fine.



3. Vissez une extrémité du tuyau d'arrivée d'eau à l'arrière de la machine à la main. Retirez le filtre à mailles de la valve située à l'arrière de l'appareil à l'aide d'une pince et nettoyez-le soigneusement à l'eau courante.

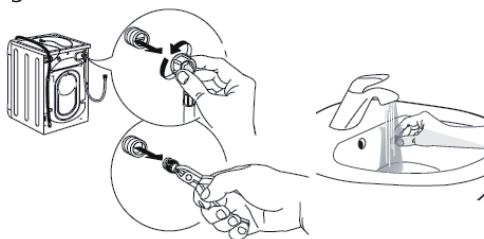

4. Insérez le filtre à mailles dans l'appareil. Raccordez le tuyau d'arrivée d'eau au robinet d'eau et à l'appareil. Ouvrez le robinet d'eau et vérifiez que toutes les connexions sont bien serrées.

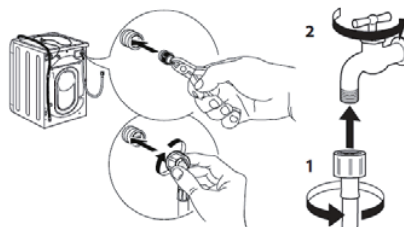

■ Nettoyage du tiroir à détergent



REMARQUE :

Il est recommandé de nettoyer le tiroir distributeur de temps en temps.

N'utilisez jamais de produits de nettoyage chimiques ou abrasifs.

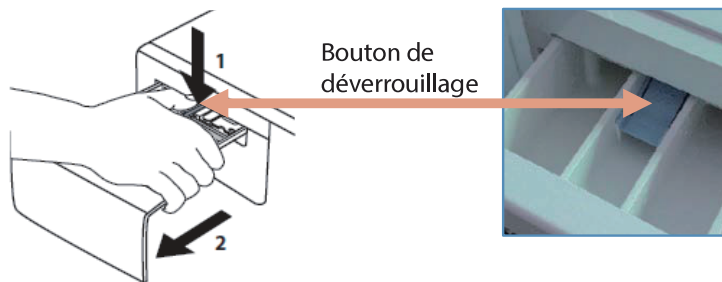

1. Retirez le tiroir en appuyant sur le bouton de déverrouillage et en tirant en même temps le tiroir hors de l'appareil.
2. Lavez toutes les pièces sous l'eau courante à l'aide d'une brosse souple ; enlevez tous les résidus de lessive et d'assouplissant.
3. Lavez le compartiment à tiroir à l'aide d'une brosse souple.
4. Remettez le tiroir en place en le poussant à l'intérieur du compartiment.

■ Nettoyage du filtre de la pompe de vidange

Le filtre de la pompe de vidange capture les fils et les petits objets oubliés dans le linge. Vérifiez régulièrement que le filtre est propre afin d'assurer le bon fonctionnement de votre machine.



AVERTISSEMENT :

Soyez prudent lors de la vidange si l'eau est très chaude. Laissez à l'eau le temps de refroidir avant de nettoyer le filtre de la pompe de vidange. Risque de brûlures !

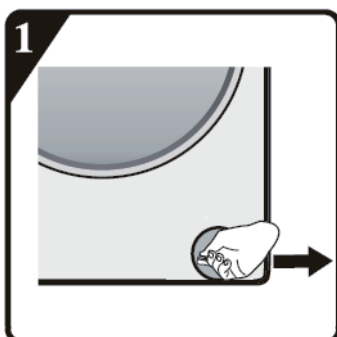

1 Insérez un petit tournevis plat dans l'ouverture du couvercle pour ouvrir le couvercle.

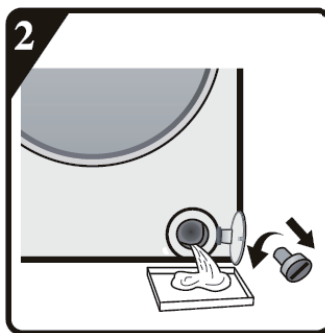

Placez un récipient bas et large sous le filtre à eau. Tournez lentement le filtre dans le sens inverse des aiguilles d'une montre jusqu'à ce que toute l'eau soit sortie.

- Une fois que le récipient est plein, fermez le filtre à eau en le tournant dans le sens des aiguilles d'une montre. Videz le récipient. Répétez la procédure jusqu'à ce que toute l'eau soit vidangée.

Retirez le filtre à eau et nettoyez-le à l'eau courante avec une brosse souple.

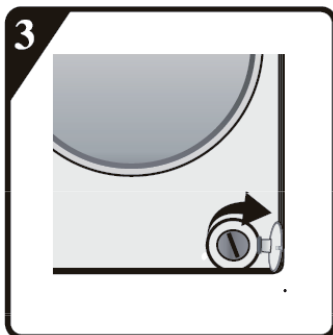

3 Remettez le filtre à eau en place dans l'appareil en le tournant dans le sens des aiguilles d'une montre

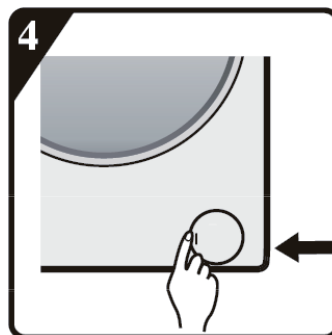

4 Fermez le couvercle jusqu'à ce qu'un déclic se fasse entendre.

GUIDE DE DÉPANNAGE

Problèmes	Causes possibles	Solutions possibles
La machine ne démarre pas.	La porte est mal fermée.	Fermez correctement la porte.
	Connexion incorrecte à l'alimentation en eau.	Vérifiez la connexion à l'alimentation en eau.
	Coupure de courant	Vérifiez l'alimentation électrique.
	Le lave-linge n'a pas été mis en marche.	Mettez la machine en marche.
Il reste de la lessive dans le tiroir à lessive après la fin du programme.	La lessive utilisée n'est pas une lessive à faible production de mousse.	Vérifiez si la lessive est appropriée.
	Quantité excessive de lessive	Réduisez la quantité de lessive dans le tiroir à lessive.
Le lave-linge vibre ou est trop bruyant.	Tous les boulons de transport n'ont pas été enlevés.	Retirez tous les boulons de transport.
	Le lave-linge est situé sur une surface irrégulière ou non plane.	Assurez-vous que le lave-linge est installé sur une surface égale et plate.
	La charge de linge dans la machine est supérieure à la capacité maximale.	Réduisez la quantité de linge dans le tambour.
Le lave-linge ne vidange pas et/ou n'essore pas.	Le tuyau de vidange est bloqué.	Débloquez le tuyau de vidange.
	Le filtre est obstrué.	Enlevez les obstructions du filtre.
	Le linge n'est pas équilibré	Ajoutez des vêtements ou faites fonctionner de nouveau le programme d'essorage.
Le résultat de lavage n'est pas satisfaisant	Votre linge est trop sale pour le programme que vous avez sélectionné.	Sélectionnez un programme adapté.
	La quantité de lessive utilisée n'est pas appropriée.	Utilisez plus ou moins de lessive, selon les instructions du fabricant.
	La charge de linge maximale a été dépassée.	Ne dépassez pas la limite de capacité maximale de la machine.
Le lave-linge ne sèche pas ou ne sèche pas correctement.	Le robinet n'est pas ouvert.	Ouvrez le robinet d'eau.
	Le filtre de la pompe de vidange est bloqué.	Assurez-vous que le filtre de la pompe de vidange n'est pas obstrué.
	La machine est mal chargée	Réduisez la charge de linge.
	Mauvais réglage du cycle	Vérifiez que vous avez réglé le bon cycle.

Codes d'erreur

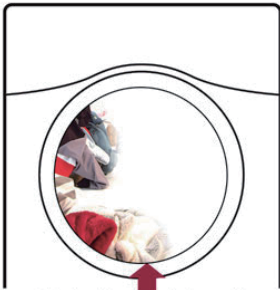
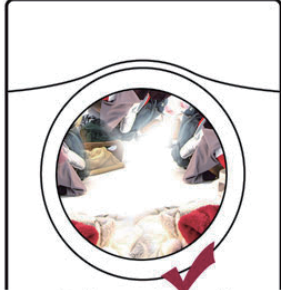
Affichage	Cause	Solution
F01	Problème d'alimentation en eau	Vérifiez si la pression de l'eau est insuffisante. Vérifiez si le tuyau d'arrivée est obstrué. Vérifiez si le filtre d'arrivée en eau est bouché. Vérifiez si le tuyau d'arrivée est gelé. Une fois le problème résolu, appuyez sur Départ/Pause .
F03	Problème de vidange	Vérifiez si le tuyau de vidange est bloqué. Vérifiez si le filtre à eau est bouché. IMPORTANT : Assurez-vous que l'eau est refroidie avant de vider l'appareil.
F13	Erreur de verrouillage de la porte	Démarrez le programme pendant 20 secondes et déverrouillez la porte pour vérifier si la porte est fermée. Ouvrez ou fermez la porte à nouveau. Une fois le problème résolu, appuyez sur Départ/Pause .
F14	Erreur de déverrouillage de la porte	Appuyez sur Départ/Pause . L'appareil va essayer d'ouvrir la porte. L'alarme ne sera désactivée que lorsque la porte sera déverrouillée. Ou tournez le sélecteur de programme sur la position Arrêt pendant 3 secondes pour éteindre la machine. Choisissez le programme souhaité pour démarrer la machine et l'alarme sera supprimée.
F24	Débordement ou trop de mousse	Supprimez le code d'erreur en appuyant sur Départ/Pause puis vidangez l'eau. Sélectionnez et démarrez le programme requis.
Autres codes d'erreur F04 à F98	Le module électronique est défaillant.	Tournez le sélecteur de programme sur la position Arrêt  pendant 3 secondes pour éteindre la machine. Une fois le problème résolu, appuyez sur Départ/Pause .
Unb	Alarme indiquant un déséquilibre	<div style="display: flex; justify-content: space-around; align-items: center;"> <div style="text-align: center;">  <p>Charge non équilibrée</p> </div> <div style="text-align: center;">  <p>Charge équilibrée</p> </div> </div> <p>Si le linge s'emmêle, séparez et réarrangez la charge de linge. Si le linge dans le tambour est trop léger, ajoutez deux serviettes ou plus.</p>

Si le problème se reproduit, débranchez le lave-linge et contactez le service après-vente.

Ouverture de la porte de secours

En cas d'échec d'ouverture de la porte en raison d'une panne de courant ou d'autres circonstances spéciales, la gâchette de déverrouillage d'urgence de la porte de la pompe de drainage peut être utilisée pour l'ouverture d'urgence.

Avant d'ouvrir la porte :



ATTENTION !

Risque de brûlures ! Assurez-vous que la température de l'eau n'est pas trop élevée et que le linge n'est pas chaud. Si nécessaire, attendez qu'ils refroidissent.



ATTENTION !

Risque de blessure ! Assurez-vous que le tambour ne tourne pas. Si nécessaire, attendez que le tambour cesse de tourner.

Pour ouvrir la porte, procédez comme suit :

1. Assurez-vous que l'appareil est éteint et que le câble d'alimentation est débranché de la prise d'alimentation.
2. Ouvrez le couvercle du filtre de la pompe de vidange.
3. Maintenez la gâchette de déverrouillage d'urgence tirée vers le bas et ouvrez en même temps la porte de l'appareil.
4. Sortez le linge, puis fermez la porte de l'appareil.
5. Enlevez le couvercle du filtre.

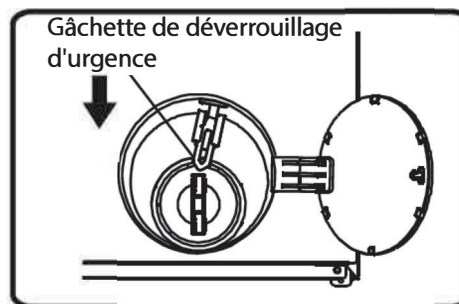

Fiche d'information sur le produit

RÈGLEMENT DÉLÉGUÉ (UE) 2019/2014 DE LA COMMISSION relatif à l'étiquetage énergétique des lave-linge ménagers et des lave-linge séchant ménagers

Nom du fournisseur ou marque commerciale: Etablissements Darty & fils © | TECNOLEC

Adresse du fournisseur: 9 Rue des Bateaux-Lavois, 94200 Ivry-sur-Seine, France

Référence du modèle: TECWD85AD

Paramètres généraux du produit:

Paramètre	Valeur		Paramètre	Valeur	
Capacité nominale (kg)	Capacité nominale ^(b)	5,0	Dimensions en cm	Hauteur	85
	Capacité nominale de lavage ^(a)	8,0		Largeur	60
				Profondeur	54
Indice d'efficacité énergétique	IEE _w ^(a)	51,6	Classe d'efficacité énergétique	IEE _w ^(a)	A
	IEE _{wd} ^(b)	67,0		IEE _{wd} ^(b)	D
Indice d'efficacité de lavage	I _w ^(a)	1,031	Efficacité de rinçage (g/kg de textile sec)	I _R ^(a)	4,5
	J _w ^(b)	1,031		J _R ^(b)	4,5

Consommation d'énergie en kWh par cycle, pour le cycle de lavage du lavelinge séchant ménager, en utilisant le programme "eco 40-60" sur une combinaison de charges pleines et partielles. La consommation réelle d'énergie dépend des conditions d'utilisation de l'appareil.	0,469		Consommation d'énergie en kWh par cycle, pour le cycle "lavage et séchage" du lavelinge séchant ménager sur une combinaison de charges pleines et partielles. La consommation réelle d'énergie dépend des conditions d'utilisation de l'appareil.	2,660	
Consommation d'eau égale en litres par cycle, pour le programme "eco 40-60" sur une combinaison de charges pleines et partielles. La consommation d'eau réelle dépend des conditions d'utilisation de l'appareil et de la dureté de l'eau.	42		Consommation d'eau égale en litres par cycle, pour le programme "eco 40-60" sur une combinaison de charges pleines et partielles. La consommation d'eau réelle dépend des conditions d'utilisation de l'appareil et de la dureté de l'eau.	80	
Température maximale à l'intérieur du textile traité(°C) pour le cycle de lavage du lavelinge séchant ménager, en utilisant le programme "eco 40-60".	Capacité nominale de lavage	34	Température maximale à l'intérieur du textile traité (°C) pour le cycle de lavage du lavelinge séchant ménager, en utilisant le cycle "lavage et séchage".	Capacité nominale	26
	Moitié	30		Moitié	26
	Quart	25			
Vitesse d'essorage (tours/min) ^(a)	Capacité nominale de lavage	1400	Taux d'humidité résiduelle pondéré(%) ^(a)	53,0	
	Moitié	1400			
	Moitié	1400			

Durée du programme "eco40-60" (h:min)	Capacité nominale de lavage	3:26	Classes d'efficacité d'essorage ^(a)	B	
	Moitié	2:48			
	Quart	2:48			
Émissions de bruit acoustique dans l'air lors de la phase d'essorage pour le cycle de lavage 'eco 40-60' à la capacité nominale de lavage [dB(A) re 1 pW]	74	Durée du cycle "lavage et séchage" (h:min)	Capacité nominale	11:30	
			Moitié	8:00	
Type	à pose libre	Émissions de bruit acoustique dans l'air en phase d'essorage pour le programme "eco 40-60" à la capacité nominale de lavage.	B		
Mode arrêt (W) (le cas échéant)	0,49	Mode veille (W) (le cas échéant)	-		
Démarrage différé (W) (le cas échéant)	3,70	Mode veille avec maintien de la connexion au réseau (W) (le cas échéant)	-		
Durée minimale de la garantie offerte par le fournisseur: 24 mois					
Ce produit a été conçu pour libérer des ions argent au cours du cycle de lavage			NON		
Informations complémentaires:					
Lien internet vers le site web du fournisseur où se trouvent les informations visées à l'annexe II, point 9, du règlement (UE)2019/2023 de la Commission: https://www.madocumentationreparation.com					

^(a) Pour le programme "eco 40-60".

^(b) Pour le cycle "lavage et séchage".

Pour accéder aux informations sur le modèle stockées dans la base de données des produits :

Cliquer sur le lien

<https://eprel.ec.europa.eu/screen/product/washerdryers2019/2265203>

Des valeurs pour des programmes:

Programme «eco 40-60» à la capacité nominale	
(a) capacité nominale en kg:	8 kg
(b) durée des programmes, exprimée en heures et minutes:	3:26
(c) consommation d'énergie, exprimée en kWh/cycle:	0,740 kWh/cycle
(d) consommation d'eau, exprimée en litres/cycle:	55 L/cycle
(e) température maximale atteinte pendant au moins 5 minutes à l'intérieur du linge en cours de traitement dans le cadre du cycle de lavage, exprimée en degrés centigrades:	34°C
(f) taux d'humidité résiduel après le cycle de lavage, exprimée en pourcentage de teneur en eau, et vitesse d'essorage à laquelle ce taux a été atteint:	53% 1400 t/m

Programme «eco 40-60» à la moitié de la capacité nominale	
(a) capacité nominale en kg:	4 kg
(b) durée des programmes, exprimée en heures et minutes:	2:48
(c) consommation d'énergie, exprimée en kWh/cycle:	0,372 kWh/cycle
(d) consommation d'eau, exprimée en litres/cycle:	40 L/cycle
(e) température maximale atteinte pendant au moins 5 minutes à l'intérieur du linge en cours de traitement dans le cadre du cycle de lavage, exprimée en degrés centigrades:	30°C
(f) taux d'humidité résiduel après le cycle de lavage, exprimée en pourcentage de teneur en eau, et vitesse d'essorage à laquelle ce taux a été atteint:	53% 1400 t/m

Programme «eco 40-60» au quart de la capacité nominale;	
(a) capacité nominale en kg:	2 kg
(b) durée des programmes, exprimée en heures et minutes:	2:48
(c) consommation d'énergie, exprimée en kWh/cycle:	0,250 kWh/cycle
(d) consommation d'eau, exprimée en litres/cycle:	30 L/cycle
(e) température maximale atteinte pendant au moins 5 minutes à l'intérieur du linge en cours de traitement dans le cadre du cycle de lavage, exprimée en degrés centigrades:	25°C
(f) taux d'humidité résiduel après le cycle de lavage, exprimée en pourcentage de teneur en eau, et vitesse d'essorage à laquelle ce taux a été atteint:	53% 1400 t/m

Programme «20 °C» à la capacité nominale de ce programme	
(a) capacité nominale en kg:	8 kg
(b) durée des programmes, exprimée en heures et minutes:	1:50
(c) consommation d'énergie, exprimée en kWh/cycle:	0,190 kWh/cycle
(d) consommation d'eau, exprimée en litres/cycle:	65 L/cycle
(e) température maximale atteinte pendant au moins 5 minutes à l'intérieur du linge en cours de traitement dans le cadre du cycle de lavage, exprimée en degrés centigrades:	21°C
(f) taux d'humidité résiduel après le cycle de lavage, exprimée en pourcentage de teneur en eau, et vitesse d'essorage à laquelle ce taux a été atteint:	55% 1400 t/m

Un programme coton à une température nominale supérieure ou égale à 60 °C (le cas échéant) à la capacité nominale de ce programme 	
(a) capacité nominale en kg:	8 kg
(b) durée des programmes, exprimée en heures et minutes:	3:29
(c) consommation d'énergie, exprimée en kWh/cycle:	1,180 kWh/cycle
(d) consommation d'eau, exprimée en litres/cycle:	68 L/cycle
(e) température maximale atteinte pendant au moins 5 minutes à l'intérieur du linge en cours de traitement dans le cadre du cycle de lavage, exprimée en degrés centigrades:	57°C
(f) taux d'humidité résiduel après le cycle de lavage, exprimée en pourcentage de teneur en eau, et vitesse d'essorage à laquelle ce taux a été atteint:	53% 1400 t/m

Un programme pour les textiles autres que le coton ou pour un mélange de textiles (le cas échéant) à la capacité nominale de ce programme 	
(a) capacité nominale en kg:	4 kg
(b) durée des programmes, exprimée en heures et minutes:	1:58
(c) consommation d'énergie, exprimée en kWh/cycle:	0,580 kWh/cycle
(d) consommation d'eau, exprimée en litres/cycle:	58 L/cycle
(e) température maximale atteinte pendant au moins 5 minutes à l'intérieur du linge en cours de traitement dans le cadre du cycle de lavage, exprimée en degrés centigrades:	38°C
(f) taux d'humidité résiduel après le cycle de lavage, exprimée en pourcentage de teneur en eau, et vitesse d'essorage à laquelle ce taux a été atteint:	55% 1400 t/m

Un programme pour le lavage rapide du linge peu sale (le cas échéant) à la capacité nominale de ce programme 	
(a) capacité nominale en kg:	1 kg
(b) durée des programmes, exprimée en heures et minutes:	0:30
(c) consommation d'énergie, exprimée en kWh/cycle:	0,310 kWh/cycle
(d) consommation d'eau, exprimée en litres/cycle:	18 L/cycle
(e) température maximale atteinte pendant au moins 5 minutes à l'intérieur du linge en cours de traitement dans le cadre du cycle de lavage, exprimée en degrés centigrades:	38°C
(f) taux d'humidité résiduel après le cycle de lavage, exprimée en pourcentage de teneur en eau, et vitesse d'essorage à laquelle ce taux a été atteint:	55% 800 t/m

un programme pour le linge très sale (le cas échéant) à la capacité nominale de ce programme 	
(a) capacité nominale en kg:	8 kg
(b) durée des programmes, exprimée en heures et minutes:	2:09
(c) consommation d'énergie, exprimée en kWh/cycle:	0,240 kWh/cycle
(d) consommation d'eau, exprimée en litres/cycle:	68 L/cycle
(e) température maximale atteinte pendant au moins 5 minutes à l'intérieur du linge en cours de traitement dans le cadre du cycle de lavage, exprimée en degrés centigrades:	20°C
(f) taux d'humidité résiduel après le cycle de lavage, exprimée en pourcentage de teneur en eau, et vitesse d'essorage à laquelle ce taux a été atteint:	53% 1400 t/m

Pour les lave-linge séchant ménagers: le cycle «lavage et séchage» à la capacité nominale	
☀️ Lavage et Séchage	
(a) capacité nominale en kg:	5 kg
(b) durée des programmes, exprimée en heures et minutes:	11:30
(c) consommation d'énergie, exprimée en kWh/cycle:	3,170 kWh/cycle
(d) consommation d'eau, exprimée en litres/cycle:	92 L/cycle
(e) température maximale atteinte pendant au moins 5 minutes à l'intérieur du linge en cours de traitement dans le cadre du cycle de lavage, exprimée en degrés centigrades:	26°C
(f) taux d'humidité résiduel après le cycle de lavage, exprimée en pourcentage de teneur en eau, et vitesse d'essorage à laquelle ce taux a été atteint:	2,90% 1400 t/m

Pour les lave-linge séchant ménagers: le cycle «lavage et séchage» à la moitié de la capacité nominale	
☀️ Lavage et Séchage	
(a) capacité nominale en kg:	2,5 kg
(b) durée des programmes, exprimée en heures et minutes:	8:00
(c) consommation d'énergie, exprimée en kWh/cycle:	1,900 kWh/cycle
(d) consommation d'eau, exprimée en litres/cycle:	63 L/cycle
(e) température maximale atteinte pendant au moins 5 minutes à l'intérieur du linge en cours de traitement dans le cadre du cycle de lavage, exprimée en degrés centigrades:	26°C
(f) taux d'humidité résiduel après le cycle de lavage, exprimée en pourcentage de teneur en eau, et vitesse d'essorage à laquelle ce taux a été atteint:	2,90% 1400 t/m

REMARQUE :

- Le programme «eco 40-60» convient au lavage du linge de coton normalement sale déclaré lavable à 40 °C ou 60 °C, au cours du même cycle.
- Ce programme est utilisé pour évaluer la conformité à la législation de l'Union en matière d'écoconception.
- Les programmes les plus efficaces au regard de la consommation d'énergie et d'eau sont généralement ceux qui fonctionnent à basse température pendant une durée plus longue.
- Le cycle «lavage et séchage» convient au lavage du linge de coton normalement sale déclaré lavable à 40 °C ou 60 °C, au cours du même cycle, et au séchage de ce linge de manière à ce qu'il puisse immédiatement être rangé, et que ce programme est utilisé pour évaluer la conformité à la législation de l'Union en matière d'écoconception.
- Charger le lave-linge ménager au maximum de la capacité mentionnée par le fabricant pour chaque programme contribue à économiser de l'énergie et de l'eau.
- Le bruit et le taux d'humidité résiduelle sont influencés par la vitesse d'essorage: plus la vitesse d'essorage est élevée lors de la phase d'essorage, plus le bruit est élevé et plus le taux d'humidité résiduelle est faible.
- Les valeurs données pour les programmes autres que le programme «eco 40-60» et le cycle «lavage» sont purement indicatives.

Caractéristiques nominales	220-240V~, 50Hz 1750W (puissance nominale) 1350W (pouvoir de séchage)
Pression d'eau	0,1 – 1 MPa
Grade de étanche	IPX4

SERVICE DE RÉPARATION ET PIÈCES DE RECHANGE



Ne démontez pas et ne réparez pas l'appareil vous-même. Ne pas respecter cette consigne peut entraîner un choc électrique ou des blessures.

Pour demander une réparation professionnelle et commander des pièces de rechange, veuillez vous adresser au service après-vente FNAC DARTY.

Les pièces de rechange pour vos appareils seront livrées sous 15 jours ouvrés après réception de la commande.

Disponibilité des pièces de rechange : une période d'au moins dix ans

Veillez noter !

Tous les appareils ont une garantie de 2 ans.

La garantie ne couvre pas les dommages causés par une mauvaise installation, une modification non autorisée, une auto-réparation ou une réparation non professionnelle.

Contactez-nous :



www.darty.com



0978 970 970
24 heures / 24
7 jours / 7



9 Rue des Bateaux-Lavois,
94200 Ivry-sur-Seine,
France

Vanden Borre
in alle vertrouwen

www.vandenborre.be



02 334 00 00
8h – 18h
Lundi à Samedi



Slesbroekstraat 101
1600 Sint-Pieters-Leeuw
Belgium

MISE AU REBUT



En tant que distributeur responsable, nous accordons une grande importance à la protection de l'environnement.

Nous vous encourageons à respecter les procédures correctes de mise au rebut de votre appareil, des piles et des éléments d'emballage. Cela aidera à préserver les ressources naturelles et à garantir qu'il soit recyclé d'une manière respectueuse de la santé et de l'environnement.

Vous devez jeter ce produit et son emballage selon les lois et les règles locales.

Puisque ce produit contient des composants électroniques et parfois des piles, le produit et ses accessoires doivent être jetés séparément des déchets domestiques lorsque le produit est en fin de vie.

Pour plus de renseignements sur les procédures de mise au rebut et de recyclage, contactez les autorités de votre commune.

Apportez l'appareil à un point de collecte local pour qu'il soit recyclé. Certains centres acceptent les produits gratuitement.



En raison des mises au point et améliorations constamment apportées à nos produits, de petites incohérences peuvent apparaître dans ces instructions. Veuillez nous excuser pour la gêne occasionnée.

Inhoudsopgave

BELANGRIJKE VEILIGHEIDSVOORSCHRIFTEN	1
PRODUCTOVERZICHT	5
INSTALLATIE.....	8
VOOR ELKE WASBEURT	11
WASSEN EN DROGEN.....	13
PROGRAMMATABEL.....	18
EXTRA FUNCTIES	20
Uitgestelde eindtijd-functie	20
Geluidsfunctie	21
Kinderslotfunctie.....	21
REINIGING EN ONDERHOUD.....	22
PROBLEEMOPLOSSING.....	24
PRODUCTINFORMATIEBLAD	26
DIENST VOOR HERSTELLINGEN EN RESERVEONDERDELEN.....	32
VERWIJDERING	33

Dit product is vervaardigd en verkocht onder de verantwoordelijkheid van Etablissements Darty et Fils (S.A.S).

en het logo zijn handelsmerken die onder licentie worden gebruikt door Etablissements Darty et Fils (S.A.S) – meer informatie op www.brand.com.

Alle andere producten, diensten, bedrijven, handelsmerken, handels- of productnamen en logo's waarnaar hierin wordt verwezen, zijn eigendom van hun respectieve eigenaars.

BELANGRIJKE VEILIGHEIDSVOORSCHRIFTEN

LEES DE VOLGENDE VEILIGHEIDSWAARSCHUWINGEN EN DE INSTRUCTIES AANDACHTIG DOOR VOORDAT U HET APPARAAT GEBRUIKT EN BEWAAR ZE VOOR LATERE RAADPLEGING.

Waarschuwingen



- Lees de instructies.
- Dit apparaat is bedoeld voor huishoudelijk gebruik en vergelijkbare toepassingen zoals:
 - kantines voor personeel in winkels, kantoren en andere werkruimtes;
 - boerderijen;
 - door klanten in hotels, motels en andere woonomgevingen;
 - bed & breakfasts en soortgelijke omgevingen.
 - ruimtes voor commercieel gebruik in appartementsblokken.
- Laat het snoer vervangen door de fabrikant, het servicecentrum of een gelijksoortig vakbekwaam persoon als het beschadigd is om elk gevaar te vermijden.
- Dit apparaat kan worden gebruikt door kinderen vanaf 8 jaar en personen met verminderde fysieke, zintuiglijke of mentale vermogens of een gebrek aan ervaring en kennis, indien zij onder toezicht staan of instructies hebben gekregen over het veilige gebruik van het apparaat en als zij de gevaren ervan begrijpen. Kinderen mogen niet met het apparaat spelen. Laat kinderen het apparaat niet zonder toezicht schoonmaken en onderhouden.
- **OPGELET:** Niet op de warmwatertoevoer aansluiten.

- Belemmer de openingen niet door een tapijt.
- De waterdruk mag niet lager zijn dan 0,1 MPa en niet hoger dan 1 MPa.
- Gebruik de nieuwe slangen die met het apparaat zijn meegeleverd en gebruik geen oude slangen opnieuw.
- Houd kinderen jonger dan 3 jaar altijd uit de buurt tenzij ze voortdurend onder toezicht staan.
- Voor meer informatie over de reinigingsmethode, zie de sectie “REINIGING EN ONDERHOUD” op pagina's 22-24.
- Het maximum gewicht aan droog textiel dat in het apparaat mag worden gestopt is 9 kg (voor de cyclus wassen) en 6 kg (voor de cyclus wassen en drogen).
- De droger mag niet worden gebruikt als er industriële chemicaliën zijn gebruikt voor de reiniging.
- De pluizenvanger moet regelmatig worden gereinigd.
- Het pluus mag zich niet ophopen rond de droger.
- Er moet worden gezorgd voor voldoende ventilatie om te voorkomen dat gassen van andere apparaten zich ophopen in de ruimte.
- Droog geen ongewassen kleding in de droogtrommel.
- Items die vervuild zijn met stoffen zoals bakolie, aceton, alcohol, benzine, kerosine, vlekkenverwijderaars, terpentijn, was en wasverwijderaars moeten in heet water worden gewassen met een extra hoeveelheid wasmiddel voordat ze in de droogtrommel worden gedroogd.
- Artikelen zoals met schuimrubber (latexschuim), badmutsen, waterdicht textiel, artikelen met een rubberen drager en kleding of kussens met schuimrubber vulling mogen niet in de droogtrommel worden gedroogd.
- Wasverzachters of soortgelijke producten moeten worden gebruikt volgens de instructies van de fabrikant.

- **Verwijder alle voorwerpen uit de zakken, zoals aanstekers en lucifers.**
- **WAARSCHUWING: Stop nooit een droger voor het einde van de droogcyclus, tenzij alle items snel worden verwijderd en uitgespreid, zodat de warmte wordt afgevoerd.**
- **WAARSCHUWING: Dit apparaat mag niet worden gevoed door een extern schakelapparaat, zoals een timer, of worden aangesloten op een circuit dat regelmatig wordt in-en uitgeschakeld.**
- **Afvoerlucht mag niet worden afgevoerd naar een schoorsteen die wordt gebruikt voor de afvoer van rookgassen van apparaten die gas of andere brandstoffen verbranden.**
- **Installeer het apparaat niet achter een vergrendelbare deur, een schuifdeur of een deur met scharnieren aan de tegenovergestelde kant van de droogtrommel, het volledig openen van de droogtrommel kan hierdoor worden belet.**

Veiligheidsmaatregelen

- **Het apparaat is alleen bestemd voor gebruik binnenshuis.**
- **Houd het verpakkingsmateriaal van het apparaat uit de buurt van kinderen om elk gevaar te voorkomen.**
- **Steek de stekker nooit met natte handen in het stopcontact.**
- **Raak het apparaat nooit met natte handen of voeten aan.**
- **In geval van een defect, haal eerst de stekker uit het stopcontact en draai de kraan dicht. Repareer het apparaat nooit zelf. Neem contact op met een erkende reparateur.**
- **Overschrijd het maximum laadvermogen niet.**
- **De glazen deur wordt zeer heet tijdens de wascyclus.**

Houd kinderen en huisdieren uit de buurt van het apparaat wanneer in werking.

- **Oefen nooit druk op de deur uit om deze tijdens de werking van het apparaat te openen.**
- **Laat kinderen nooit zonder toezicht in de buurt van het apparaat, ze kunnen zichzelf in het apparaat opsluiten.**
- **Na gebruik, haal de stekker uit het stopcontact en draai de waterkraan dicht.**
- **Dieren en kinderen kunnen in de machine klimmen. Controleer de machine voor elk gebruik.**
- **De stekker moet na het installeren van het apparaat eenvoudig bereikbaar zijn.**
- **Was geen artikelen die met brandbare of explosieve stoffen (zoals was, olie, verf, benzine, ontvettingsmiddelen, chemische oplosmiddelen, kerosine, etc.) zijn gereinigd, gewassen, geweekt of gedept. Dit kan brand of explosie tot gevolg hebben.**
- **Installeer het apparaat niet in een badkamer, een zeer vochtige kamer of in een ruimte met explosieve of bijtende gassen.**

PRODUCTOVERZICHT

Lade
(voor wasmiddel
en wasverzachter)

Bedieningspaneel

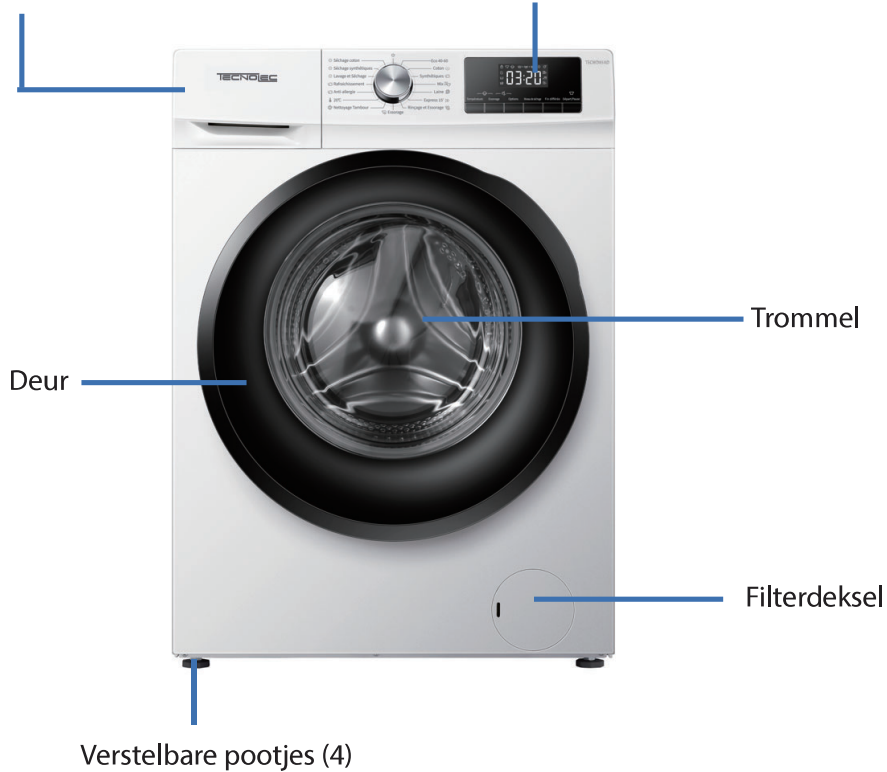

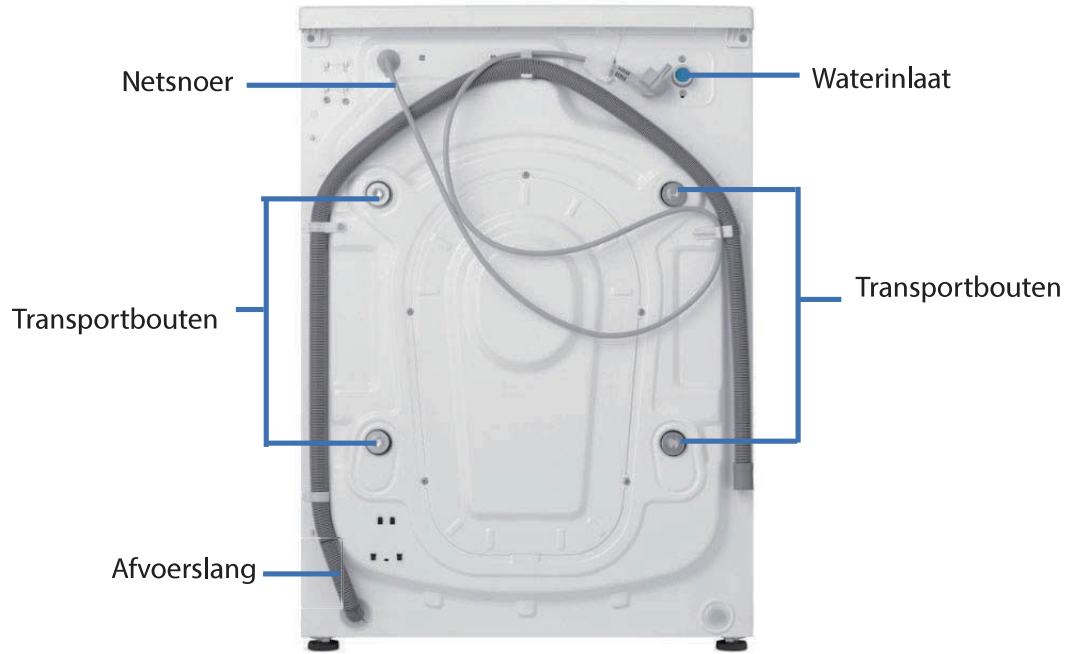

Toebehoren



Afdekkapjes



Inlaatslang



Bodemplaat



U-beugel



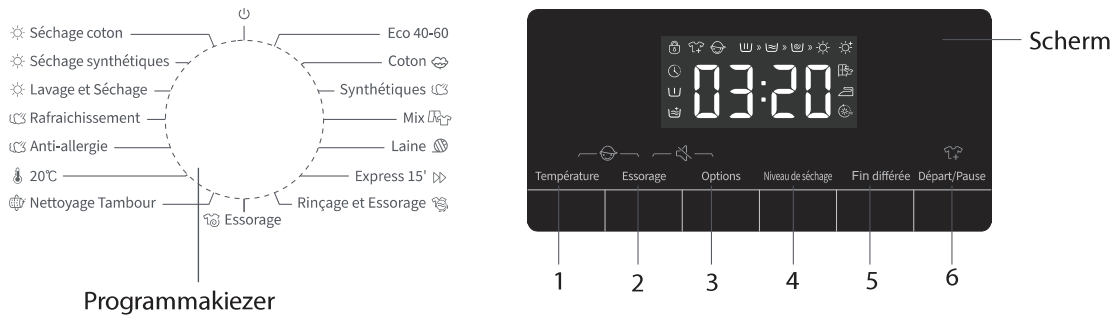

Moersleutel

Bedieningspaneel









- 1 Temperatuur knop
- 2 Centrifuge knop
- 3 Optie knop
- 4 Droogniveau knop
- 5 Einde vertraging knop
- 6 Start/Pauze knop

- 1 + 2  Kinderslotfunctie
- 2 + 3  Geluidsfunctie
- 6  Herladenfunctie





Indicatoren op het display



Om de wasduur, snelheid, foutcode, temperatuur weer te geven

					
Deur vergrendeld	Herladen	Kinderslot	Einde vertraging	Voorwas	Extra spoelen

Droogniveausymbolen

			
Extra droog	Kastdroog	Strijkdroog	Getimed drogen

De symbolen verschijnen op het display wanneer de overeenkomstige fase is ingesteld.



INSTALLATIE

■ Verpakking verwijderen

1. Verwijder de kartonnen doos en de piepschuimverpakking.
2. Til de wasmachine op en verwijder de basisverpakking. Hiervoor zijn 2 of meer mensen nodig.
3. Verwijder de tape waarmee het netsnoer en de afvoerslang zijn bevestigd.



WAARSCHUWING:

Verpakkingsmateriaal (bijv. folie, piepschuim) kan gevaarlijk zijn voor kinderen. Er bestaat verstikkingsgevaar! **Houd alle verpakking uit de buurt van kinderen.**

■ Transportbouten verwijderen

Het apparaat is uitgerust met transportbouten om interne beschadiging tijdens het transport te vermijden.

Verwijder de verpakking en alle transportbouten voor gebruik van het apparaat.

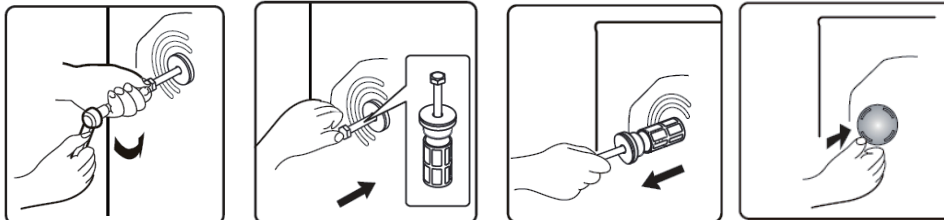

1. Draai de boutkoppen tegen de klok in los met behulp van een moersleutel totdat de bouten gedeeltelijk zijn ingetrokken.
2. Duw de transportbouten naar binnen om ze los te maken.
3. Verwijder de transportbouten en de rubber bussen door ze uit te trekken.
4. Sluit de openingen af met de meegeleverde afdekkappen.

■ Plaatsbepaling

Plaats het apparaat op een vlak en hard oppervlak.
Zorg ervoor dat de luchtcirculatie rond het apparaat niet wordt gehinderd door tapijten, vloerkleden etc.
Laat een ruimte van minstens 2 cm aan elke kant van het apparaat.
Zorg ervoor dat het apparaat niet op het netsnoer staat.

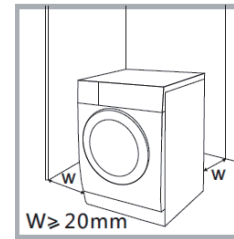

■ Vereisten voor de installatielocatie

Voor het installeren van het apparaat, kies een gepaste plaats die aan de volgende voorwaarden voldoet:

- Stevige, droge en vlakke ondergrond
- Vermijd direct zonlicht.
- Voldoende ventilatie
- Kamertemperatuur is hoger dan 0°C
- Blijf uit de buurt van warmtebronnen zoals kolen- of gasgestookte apparaten.

■ Het apparaat waterpas stellen

Door de wasmachine goed waterpas te stellen, worden overmatig lawaai en trillingen voorkomen. Installeer het apparaat op een stevige en vlakke ondergrond.

Als de vloer ongelijk is, draai dan de verstelbare pootjes zoals vereist.

- Leg nooit kartonnen dozen, houten blokken of soortgelijke materialen onder de voeten.

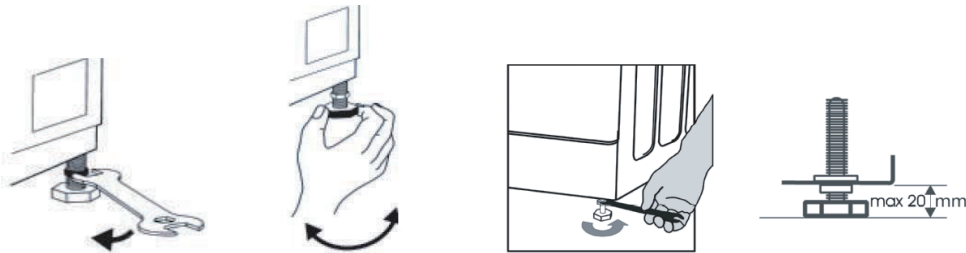

1. Draai de borgmoeren los met een steeksleutel.
2. Draai aan de verstelbare pootjes om de hoogte aan te passen.
 - Zorg ervoor dat alle vier de voeten stabiel zijn en op de grond rusten en controleer vervolgens met een waterpas of het apparaat perfect waterpas staat.
3. Draai de borgmoeren.

■ De bodemplaat installeren

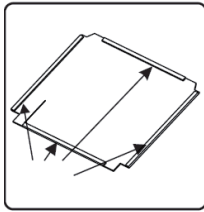

1. Verwijder het achterblad van het dubbelzijdig plakband dat op de vier zijden van de bodemplaat is aangebracht.

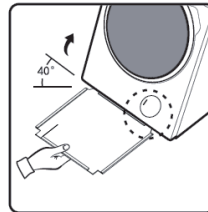

2. Kantel het apparaat naar achteren (kantelhoek: 40°) en breng de bodemplaat aan.

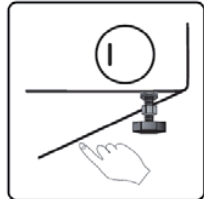

3. Oefen druk uit op het dubbelzijdig plakband om de bodemplaat aan het apparaat vast te maken.

Opgelet: Voor betere prestaties wat betreft het geluidsniveau, breng de inbegrepen "geluiddempende bodemplaat" aan. Lees en volg de installatiehandleiding zoals aangegeven op de geluiddempende plaat en in de gebruiksaanwijzing.

■ Elektrische aansluiting

Uw wasmachine werkt met 220-240V en 50Hz.

Elektrische aansluitingen moeten worden uitgevoerd door een gekwalificeerde technicus in overeenstemming met de geldende veiligheidsvoorschriften.

Uw wasmachine moet juist geaard worden. We zijn niet verantwoordelijk voor schade als gevolg van gebruik zonder juiste aardverbinding.

Gebruik geen verlengsnoeren of stekkerdozen.

Dit apparaat mag niet worden gevoed door een extern schakelapparaat, zoals een timer, of worden aangesloten op een circuit dat regelmatig wordt in- en uitgeschakeld.

Trek de stekker niet uit het stopcontact als er brandbaar gas in de buurt is.

■ De slang aansluiten

De watertoevoerslang aansluiten



Het apparaat moet op de koudwatertoevoer worden aangesloten.

Zorg dat er geen knik in de slang zit en de slang niet wordt verpletterd.

1. Schroef één uiteinde van de inlaatslang vast op de achterkant van het apparaat.

2. Sluit het ander uiteinde van de inlaatslang aan op een kraan met een $\frac{3}{4}$ " draad.

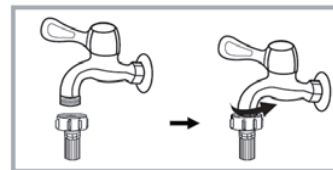
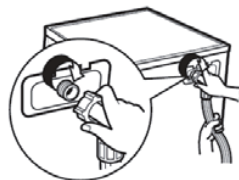

OPMERKING :

Na het aansluiten van de slang, draait u de kraan langzaam open en controleert u of er geen lek is.

De slang niet verdraaien, platdrukken, wijzigen of doorknippen.

De afvoerslang installeren

Om een afvoerslang te installeren, gebruik een van de volgende methoden:
Zorg dat de afvoerslang niet gebogen, kromgetrokken, verpletterd of verlengd is.

- Duw de slang stevig in een afvoerstandpijp.

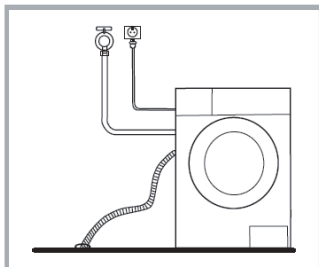

- Wanneer de afvoerslang in een gootsteen wordt aangebracht, zet het stevig vast met een koord.

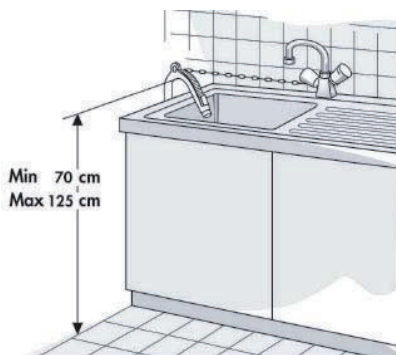

OPMERKING:

Monteer de waterafvoerslang op een hoogte van minimum 70 cm en maximum 125 cm van de grond.

VOOR ELKE WASBEURT

Regels voor het scheiden van wasgoed

- Type stof / symbool op het waslabel (katoen, gemengde vezels, synthetisch, wol, handgewassen items)
- Kleur
Scheid gekleurde en witte items. Was nieuwe en gekleurde items afzonderlijk.
- Grootte
Was items van verschillende groottes in dezelfde lading voor betere wasprestaties en verdeling van de items in de trommel.
- Delicate items
Was delicate items afzonderlijk.
- Babyartikelen (babykleding, handdoeken en luiers) moeten afzonderlijk worden gewassen. Als deze samen met kledingstukken voor volwassenen worden gewassen, kunnen ze geïnfecteerd raken. Verleng de spoelcyclus om ervoor te zorgen dat alle wasmiddel volledig uit het wasgoed is verdwenen.
- Het is aanbevolen om items die eenvoudig bevestigd kunnen worden, zoals witte sokken, kragen en mouwen, etc. eerst met de hand te wassen alvorens ze in de wasmachine te steken om betere wasprestaties te krijgen.

De zakken leegmaken



Controleer of alle zakken leeg zijn. Voorwerpen zoals spijkers, haarclips, aanstekers, muntstukken en sleutels kunnen zowel uw apparaat als uw kleding beschadigen.

Alle ritssluitingen, knopen en haken sluiten

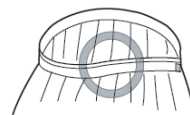
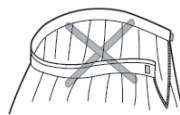

Sluit ritssluitingen, haken en koorden om te vermijden dat deze voorwerpen aan andere kledingstukken vast komen te zitten.

Knoop alle linten en riemen dicht.

Wasmiddel

Lees de instructies op de verpakking met was- of ander middel voor de juiste hoeveelheid, afhankelijk van de hoeveelheid wasgoed, de mate van vervuiling en de waterhardheid.

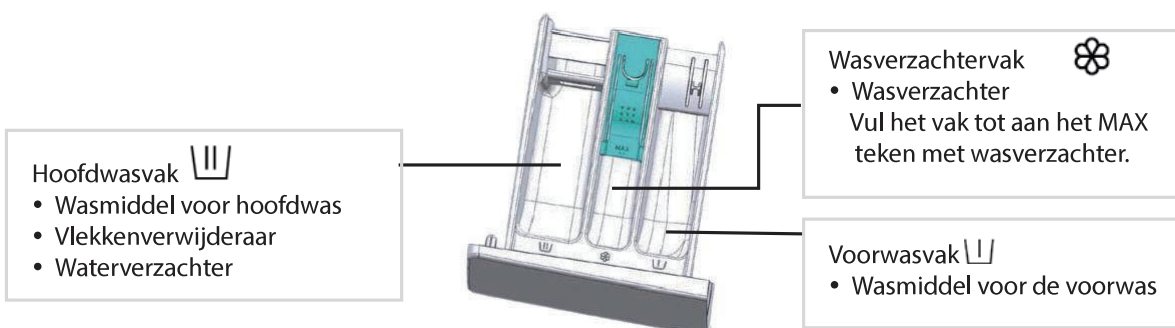

Het gepaste wasmiddel is afhankelijk van:

- type stof (katoen, strijkvrij/ synthetisch, delicate items, wol).
- **Opmerking:** Gebruik alleen specifieke wasmiddelen voor het wassen van wol.
- Kleur
- wastemperatuur
- graad en soort vervuiling

Opmerkingen:

- Witte resten op donkere stoffen worden veroorzaakt door onoplosbare verbindingen die in moderne fosfaatvrije waspoeders worden gebruikt. Als dit het geval is, schud of borstel de stof uit of gebruik een vloeibaar wasmiddel.
- Gebruik alleen wasmiddelen en wasverzachters die speciaal voor huishoudelijke wasmachines zijn ontworpen.
- Wanneer ontkalkingsmiddel, kleurstof of bleekmiddel tijdens de voorwas wordt gebruikt, zorg dat het geschikt is voor gebruik in een huishoudelijke wasmachine. Ontkalkingsmiddelen kunnen producten bevatten die uw wasmachine kunnen beschadigen.
- Gebruik geen oplosmiddelen (zoals terpentijn of benzeen). Was geen stoffen in de wasmachine die met een oplosmiddel of brandbare vloeistof zijn behandeld.
- Berg wasmiddel en additieven op in een droge en veilige ruimte, en buiten het bereik van kinderen.
- Om doseerproblemen te voorkomen bij het gebruik van sterk geconcentreerde waspoeders en vloeibare wasmiddelen, gebruik de speciale doseerbalk of -zakje die bij het wasmiddel is geleverd en plaats deze direct in de trommel.

WASSEN EN DROGEN

Voor de eerste wascyclus

Om eventueel restwater te verwijderen dat tijdens het testen door de fabrikant is achtergebleven, is het raadzaam een korte wascyclus zonder wasgoed uit te voeren.

1. Draai de waterkraan open.
2. Sluit de deur.
3. Giet voor de wasfase een kleine hoeveelheid wasmiddel in het handmatig doseerbakje voor vloeibaar wasmiddel/waspoeder.
4. Selecteer en start een kort programma.

Uw wasgoed wassen en drogen

1. Open de deur om de artikelen in de trommel te laden.



OVERBELAST het apparaat NIET.

Houd rekening met het maximum gewicht van de lading die in de programmatabel is vermeld.

Het apparaat overbelasten leidt tot een afname van de wasprestaties.

2. Sluit de deur.

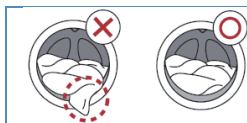

Zorg dat er geen wasgoed tussen de deur en afdichting vast komt te zitten.

3. Voeg wasmiddel en wasverzachter toe.

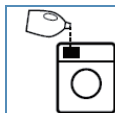

Trek het bakje uit.

Doe wasmiddel en wasverzachter in de overeenkomstige vakken.

Niet laten overlopen.

4. Draai de watertoevoer open.

5. Selecteer het gewenste programma.

Draai de programmakeuzeknop om het gewenste programma te selecteren.

Het scherm geeft de wastijd weer.



De programmakeuzeknop wordt ook gebruikt om de machine in of uit te schakelen.

Zie de programmatabel voor een gedetailleerd programmaoverzicht.

6. Wijzig de temperatuur, indien nodig.

Druk herhaaldelijk op **Température** totdat de gewenste temperatuur is ingesteld.





7. Wijzig de centrifugesnelheid, indien nodig.

Druk herhaaldelijk op **Essorage** om de gewenste centrifugesnelheid in te stellen.

8. Selecteer indien nodig extra functies.

Druk herhaaldelijk op **Options** om de gewenste optie te selecteren. De opties zijn alleen beschikbaar wanneer bepaalde programma's worden geselecteerd.

Het scherm geeft het overeenkomstig symbool weer wanneer de optie wordt gekozen.

<p> Voorwas Selecteer deze optie voor het wassen van sterk vervuild wasgoed. Vòòr het wassen kan het wasmiddel/waspoeder worden toegevoegd aan het voorwasvak en het waspoeder moet worden toegevoegd aan het hoofdwasvak.</p>	 <p>Diagram illustrating the control panel for the 'Voorwas' (Pre-wash) option. A central circular button is labeled 'Beschikbaar voor deze programma's' (Available for these programs). To its left, the 'Anti-allergie' (Anti-allergy) and '20°C' options are shown. To its right, the 'Coton' (Cotton), 'Synthétiques' (Synthetics), and 'Mix' options are shown.</p>
<p> Extra Spoelen Selecteer deze optie om een extra spoelcyclus uit te voeren voor betere spoelprestaties.</p>	 <p>Diagram illustrating the control panel for the 'Extra Spoelen' (Extra Rinse) option. A central circular button is labeled 'Beschikbaar voor deze programma's' (Available for these programs). To its left, the 'Anti-allergie' (Anti-allergy) and '20°C' options are shown. To its right, the 'Coton' (Cotton), 'Synthétiques' (Synthetics), 'Mix', 'Laine' (Wool), 'Express 15'' (Express 15'), and 'Rinçage et Essorage' (Rinse and Spin) options are shown.</p>

9. Selecteer het gewenste droogniveau.

Druk herhaaldelijk op **Niveau de séchage** om het gewenste droogniveau te selecteren en het display geeft het symbool van het ingestelde niveau weer:

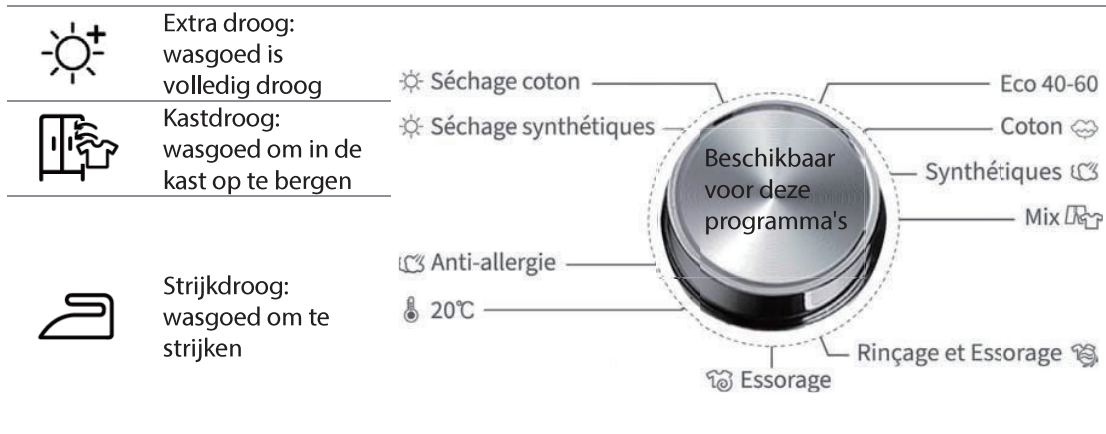

Het apparaat kan het gewicht van de kleding detecteren om de droogtijd automatisch aan te passen. Controleer voor het drogen of de kleding gedroogd kan worden.

Niet wasbaar • droog / niet-droge kleding

Kleding die niet gewassen of gedroogd kan worden



Producten van leer en bont
(Kan leiden tot vervorming.)



Rayon en zijn gemengde producten
(Verkleuring of vervorming kan worden veroorzaakt.)

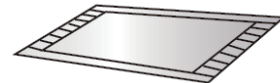

Grote dikke rubberen kussens met carbamaat aan de achterzijde
(Schade of fout kan worden veroorzaakt.)



Hoeden met hard materiaal
(De machine zal worden beschadigd en storingen zullen optreden.)



Kussens, artikelen met katoenen watten, schuimrubber en andere sponsmaterialen, vloerbedekking
(Schade of fout kan worden veroorzaakt.)

Overige:
Gekreukte of gebosseleerde kleding;
crêpe stoffen;
Eenvoudig vervormde kleding (pakken, jassen, stropdassen en jurken, etc.);
Kleding die eenvoudig pluist (fluweel, katoenfluweel).

Kleding die niet gedroogd kan worden

 <p>Alle kleding voorzien van bovenstaande afbeeldingen (Kleding kan worden beschadigd.)</p>	 <p>Wollen kleding (Krimpen en verlies van stof kunnen worden veroorzaakt.)</p>	 <p>Panty's, kousen (Schade of vervorming kan worden veroorzaakt.)</p>	 <p>Op maat gemaakte kleding</p>
 <p>Kussens of kleding met bont (Schade of fout kan worden veroorzaakt.)</p>	 <p>Dekbed (Schade of fout kan worden veroorzaakt.)</p>	 <p>Kleding met kant en borduurwerk, nieuwe synthetische vezels (zeer fijne vezels) (Vervorming kan worden veroorzaakt.)</p>	 <p>Zijde</p>

Opmerking!

Niet-wasbare droge/niet-droge kleding omvat, maar is niet beperkt, tot de bovenstaande kleding. Natte kleding die druipt is niet geschikt om te drogen. Het alarm van de machine kan afgaan!

Droogtijd

Wanneer het display het symbool



weergeeft, druk

herhaaldelijk op **Niveau de séchage** om de tijd in te stellen die geschikt is voor de stoffen die u wilt drogen. Het display toont de ingestelde tijd (30 minuten, 1 uur, 1,5 uur, 2 uur, 3 uur en 4 uur).



- Haal de gedehydrateerde kleding uit elkaar en doe de kledingstukken vervolgens apart in de trommel om ze te drogen.
- Als er weinig kleding of alleen lichte kleding wordt gedroogd, kan de droogtijd korter zijn dan de ingestelde tijd.

- Als u met de hand gewassen kleding wilt drogen, voordat u de kleding droogt, selecteer eerst centrifuge op hoge snelheid afhankelijk van het soort kleding. Het wordt aanbevolen om de programma's „Centrifuge + Droogniveau” te selecteren.
- Aan het einde van het droogprogramma draait de machine gedurende enige tijd op een bepaalde snelheid om de kleding los te maken en kreuken te beperken.
- Te veel in één keer drogen kan een negatieve impact op de droogprestaties hebben en overmatig drogen kan leiden tot kreuken in de kleding. Voor kleding uit chemische vezels, zoals overhemden, etc., selecteer strijkdroog .
- Als kleding uit verschillende soorten stoffen samen wordt gedroogd, kan dit een negatieve impact op de droogprestaties hebben. Het wordt aldus aanbevolen om de kleding voor het drogen goed te sorteren.

10. Start een programma.

Druk op **Départ/Pause**. De deur wordt vergrendeld en het scherm geeft het symbool  weer.





Deze symbolen geven de programmafases aan, van links naar rechts. Het overeenkomstig symbool knippert om de huidige fase aan te geven.

Automatisch wegen

Het display geeft “----” na het starten van een programma weer om aan te geven dat het wasgoed automatisch wordt gewogen. De programmaduur (uren:minuten) wordt vervolgens automatisch aangepast aan het gewicht van het wasgoed.

11. Onderbreek een actief programma en open de deur, indien nodig.

- Druk op **Départ/Pause** om een actief programma te onderbreken.
- Als het waterpeil of de temperatuur niet te hoog is, verdwijnt het deur vergrendeld symbool  en geeft het scherm het herladen symbool  weer.
U kunt nu de deur openen om bijv. meer wasgoed toe te voegen of wasgoed te verwijderen dat per ongeluk in de machine werd gestopt.
- Druk op **Départ/Pause** om het programma te hervatten.

12. Wijzig een programma en de instellingen, indien nodig.

Om de instellingen van een actief programma te wijzigen:



- Draai de programmakeuzeknop naar de stand UIT  circa 3 seconden.
- Selecteer een nieuw programma en wijzig de instellingen.
- Druk op **Départ/Pause** om het nieuw programma te starten.

13. Aan het einde van de cyclus geeft het scherm het bericht „End” (einde).

14. Schakel de machine uit door de programmakeuzeknop naar de UIT-stand te draaien.

15. Open de deur en haal het wasgoed uit.

















- De deur kan alleen worden geopend wanneer het symbol  verdwijnt. Controleer of het symbol  verdwijnt.
- Open de deur en haal het wasgoed uit.
- Laat de deur op een kier om de binnenkant van het apparaat te laten drogen.

















Draai de waterkraan dicht.

PROGRAMMATABEL

Programma	Functies	Max lading (kg)	Temperaturen	Max. centrifugesnelheid (omw/min)
 Séchage coton Katoen drogen	Drogen	5	—	—
 Séchage synthétiques Synthetische stoffen drogen	Drogen	5	—	—
 Lavage et Séchage Wassen en drogen	Wassen en drogen	5	—	1400
 Rafraichissement Opfrissen met stoom	Drogen	2	—	—
 Anti-allergie Anti-allergie	Wassen	4	40°C, 60°C, 90°C	1400
	Wassen en drogen	4		
 20°C	Wassen	8	20°C	1400
	Wassen en drogen	5		
 Nettoyage Tambour Trommel reinigen	Wassen en drogen	—	90°C	800
Eco 40-60	Wassen	8	—	1400
	Wassen en drogen	5		
Coton  Katoen	Wassen	8	Koud, 20°C, 30°C, 40°C, 60°C, 90°C	1400
	Wassen en drogen	5		
Synthétiques  Synthetics	Wassen	8	Koud, 20°C, 30°C, 40°C, 60°C	1200
	Wassen en drogen	5		1400
Mix  Gemengd	Wassen	4	Koud, 20°C, 30°C, 40°C	1400
	Wassen en drogen			
Laine  Wol	Wassen	2	Koud, 20°C, 30°C, 40°C	600
Express 15'  Snel 15'	Wassen	1	Koud, 20°C, 30°C, 40°C	800

Rinçage et Essorage  Spoelen en centrifugeren	Wassen	8	—	1400
	Wassen en drogen	5		
 Essorage Centrifugeren	Centrifugeren	8	—	1400
	Centrifugeren en drogen	5		

Programma	Beschrijving van programma (Type lading en vuilgraad)	Wasmiddelen en additieven		
		Voorwas I	Hoofdwas II	Wasverzachter 
 Séchage coton Katoen drogen	Natte katoenen en linnen kleding kan na het centrifugeren worden gedroogd.	—	—	—
 Séchage synthétiques Synthetische stoffen drogen	Natte kleding uit chemische vezels kan na het centrifugeren worden gedroogd.	—	—	—
 Lavage et Séchage Wassen en drogen	De cyclus wassen en drogen geschikt is voor het reinigen van normaal bevuild katoenen wasgoed waarvan is aangegeven dat het op 40 °C of 60 °C kan worden gewassen, samen in dezelfde cyclus, dat deze cyclus geschikt is om dit wasgoed zodanig te drogen dat het onmiddellijk in een kast kan worden opgeborgen en dat dit programma wordt gebruikt om na te gaan of de EU-regelgeving inzake ecologisch ontwerp wordt nageleefd.	○	●	○
 Rafrachissement Oprissen met stoom	Het is geschikt voor het verwijderen van onaangename geuren (zoals de geur van rook/fondue/barbecue, etc.) op kleding.	—	—	—
 Anti-allergie Anti-allergie	Programma om bacteriën in textiel effectief te doden. Het is geschikt voor kleding van baby's die gevoelig zijn voor kleding.	○	●	○
 20°C	Een wascyclus die geschikt is voor het reinigen van licht bevuild katoenen wasgoed op een nominale temperatuur van 20 °C	○	●	○
 Nettoyage Tambour Trommel reinigen	Programma om vuil en bacterieresten te verwijderen die in de machine kunnen ophopen nadat deze gedurende een bepaalde periode is gebruikt, vooral wanneer het apparaat regelmatig wordt gebruikt voor wasbeurten op een lage temperatuur.	—	—	—
Eco 40-60	Een wascyclus die geschikt is voor het reinigen van normaal bevuild katoenen wasgoed waarvan is aangegeven dat het op 40 °C of 60 °C kan worden gewassen, samen in dezelfde cyclus	○	●	○

Coton  Katoen	Voor het wassen van zeer en normaal bevuild wasgoed van katoen en linnen Voor zeer bevuild wasgoed, selecteer de „Voorwas“ functie	<input type="radio"/>	<input checked="" type="radio"/>	<input type="radio"/>
Synthétiques  Synthetics	Voor matig vervuilde synthetische stoffen en gemengde katoenstoffen	<input type="radio"/>	<input checked="" type="radio"/>	<input type="radio"/>
Mix  Gemengd	Voor gemengde ladingen van matig vervuilde katoen en synthetische stoffen	<input type="radio"/>	<input checked="" type="radio"/>	<input type="radio"/>
Laine  Wol	Voor machinewasbare wol. (Raadpleeg het waslabel dat aan de kleding is bevestigd).	<input type="radio"/>	<input checked="" type="radio"/>	<input type="radio"/>
Express 15'  Snel 15'	Voor het snel wassen van licht bevuild wasgoed	<input type="radio"/>	<input checked="" type="radio"/>	<input type="radio"/>
Rinçage et Essorage  Spoelen en centrifugeren	Dit programma is standaard ingesteld op twee spoelbeurten en centrifugeren.	—	—	<input type="radio"/>
 Essorage Centrifugeren	Extra centrifuge met instelbare centrifugesnelheid	—	—	—

● = dosering vereist / ○ = optioneel

EXTRA FUNCTIES

■ Uitgestelde Eindtijd-functie

U kunt deze functie gebruiken om het programma zo in te stellen dat het op een later tijdstip wordt beëindigd. De uitgestelde eindtijd kan worden gekozen tussen 1 en 24 uur, in stappen van 1 uur.

1. Selecteer een programma.
2. Druk herhaaldelijk op **Fin différée** om de gewenste eindtijd te selecteren.
 - Het weergegeven uur geeft de tijd aan wanneer het programma zal eindigen.
 - Het  symbool verschijnt op het scherm.
3. Druk op **Départ/Pause** om het programma te starten.
 - De machine zal vervolgens aftellen.

Als de programmaduur bijvoorbeeld langer dan 2 uur is, dan moet de uitgestelde eindtijdfunctie starten vanaf 3 uur.

Als de programmaduur van uw geselecteerde programma 2:28 uur is en u stelt de uitgestelde eindtijd in op 6 uur. Dit betekent dat uw wasprogramma binnen 6 uur zal eindigen.

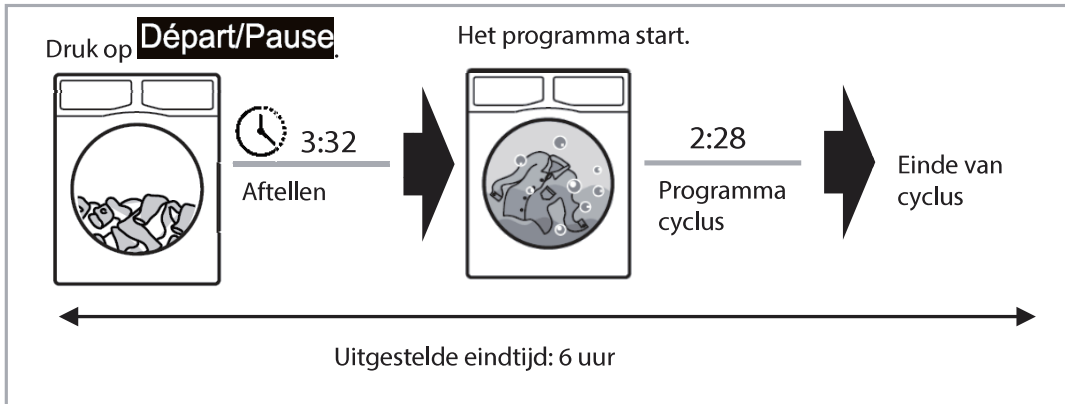

Als u deze functie wilt annuleren voordat het programma start, druk herhaaldelijk op **Fin différée**

totdat het symbool  van het display verdwijnt.

Als u deze functie na het starten van het programma wilt annuleren, schakel het apparaat uit door de programmakeuzeknop naar de UIT-stand te draaien.

■ Geluidsfunctie

U kunt deze functie gebruiken om het geluid dat tijdens het drukken op de knoppen of het draaien aan de programmakeuzeknop wordt geproduceerd in of uit te schakelen.

- Druk en houd de **Essorage** en **Options** tegelijkertijd gedurende circa 2 seconden ingedrukt totdat het scherm "bEEp OFF" weergeeft. Dit geeft aan dat het geluid is uitgeschakeld.
- Om deze functie uit te schakelen, druk en houd **Essorage** en **Options** opnieuw tegelijkertijd gedurende circa 2 seconden. Het scherm "bEEp ON" weergeeft.

■ Kinderslotfunctie

Om de veiligheid van kinderen te vergroten, is deze machine uitgerust met een kinderslotfunctie.

Wanneer het programma start, druk en houd **Température** en **Essorage** 2 seconden tegelijkertijd ingedrukt. Het symbool  verschijnt op het display om aan te geven dat de functie geactiveerd is. Wanneer de functie is geactiveerd, worden alle functieknoppen vergrendeld.

Om deze functie te deactiveren, druk en houd **Température** en **Essorage** 2 seconden tegelijkertijd ingedrukt. Het symbool  verdwijnt van het display.

- Wanneer u de machine uitschakelt door de programmakeuzer naar de positie Off (Uit)  te draaien, wordt de kinderslotfunctie gedeactiveerd.
- Nadat het programma is afgelopen, wordt het kinderslot automatisch ontgrendeld.

REINIGING EN ONDERHOUD



WAARSCHUWING:

Haal altijd de stekker uit het stopcontact en draai de waterkraan dicht voor reiniging en onderhoud.

■ Het bedieningspaneel/de buitenkant van het apparaat reinigen

Veeg af met een zachte, vochtige doek.

Gebruik geen schurende of chemische schoonmaakmiddelen.

Was- en reinigingsmiddelresten onmiddellijk verwijderen.

■ De trommel reinigen

Roestvlekken die door metalen voorwerpen in de trommel zijn achtergebleven, moeten onmiddellijk worden verwijderd met chloorvrije wasmiddelen. Gebruik nooit staalwol om de trommel te reinigen!

Om de trommel te ontkalken, voert u de trommelreiniging uit met het ontkalkingsmiddel volgens de instructies van de fabrikant voor de juiste dosering van het wasmiddel.

■ De deurdichting en het glas reinigen

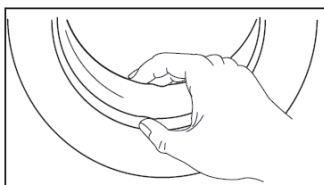

Veeg het glas en de dichting na elke wascyclus schoon om pluis en vlekken te verwijderen. Als pluis wordt opgehoopt kan lekkage optreden.

Haal muntstukken, knopen en andere voorwerpen na elke wascyclus uit de dichting.

Maak de deurafdichting en het glas elke maand schoon om de normale werking van de machine te garanderen.

■ De inlaatfilter reinigen



OPMERKING :

Reinig het inlaatfilter als het water niet goed wordt toegevoerd.

Als het water erg hard is of sporen van kalkafzetting bevat, kan het watertoevoerfilter verstopt raken. Het wordt aanbevolen om het inlaatfilter van tijd tot tijd te reinigen.

1. Draai de watertoevoer dicht en maak de inlaatslang los.

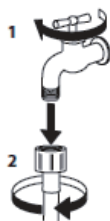

2. Reinig de gaasfilter aan het slanguiteinde voorzichtig met een fijne borstel.



3. Schroef de inlaatslang opnieuw met de hand vast op de achterkant van het apparaat. Trek

4. Breng de gaasfilter opnieuw aan in het apparaat. Sluit de inlaatslang aan op de waterkraan en het

de gasfilter uit het ventiel aan de achterkant van het apparaat met behulp van een tang en reinig het voorzichtig onder stromend water.

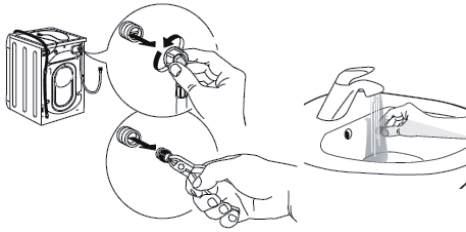

apparaat. Draai de waterkraan open en controleer of alle verbindingen stevig zijn vastgemaakt.

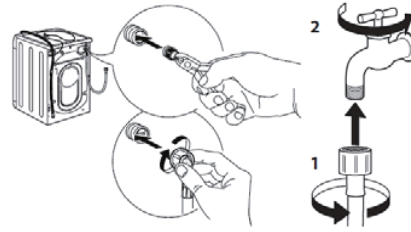

■ De wasmiddellade reinigen



OPMERKING :

Het wordt aanbevolen om de wasmiddellade van tijd tot tijd schoon te maken. Gebruik geen schurende of chemische schoonmaakmiddelen.

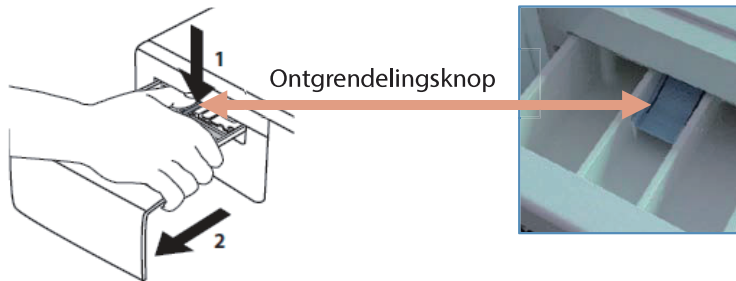

1. Verwijder het bakje door tegelijkertijd op de ontgrendelingsknop te drukken en het bakje uit het apparaat te trekken.
2. Reinig alle onderdelen onder stromend water en gebruik een zachte borstel om alle wasmiddel- en wasverzachterresten te verwijderen.
3. Reinig de opening voor het bakje in het apparaat met behulp van een zachte borstel.
4. Duw het bakje opnieuw in het apparaat totdat het goed vastzit.

■ De afvoerpompfilter reinigen

Het afvoerpompfilter vangt draden en kleine voorwerpen op die in het wasgoed zijn achtergebleven. Controleer regelmatig of het filter schoon is om een soepele werking van uw machine te garanderen.



WAARSCHUWING:

Wees voorzichtig bij het aftappen als het water heet is. Laat het water afkoelen voordat u het filter van de afvoer pomp reinigt. Gevaar voor verbranding!

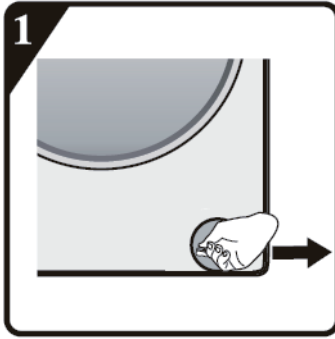

1 Steek een kleine platte schroevendraaier in de opening van het deksel om het deksel open te wrikken.

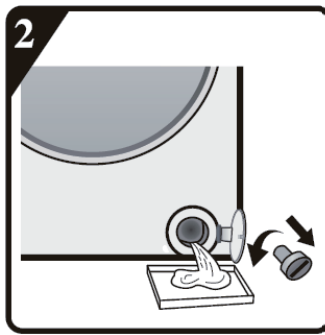

Plaats een lage en brede bak onder de waterfilter.
Draai de filter langzaam tegen de klok in totdat alle water is afgevoerd.

- Wanneer de bak vol is, sluit de waterfilter door het met de klok mee te draaien. Verwijder het reservoir. Herhaal de procedure totdat alle water is afgevoerd.

Verwijder de waterfilter en reinig het onder stromend water met behulp van een zachte borstel.

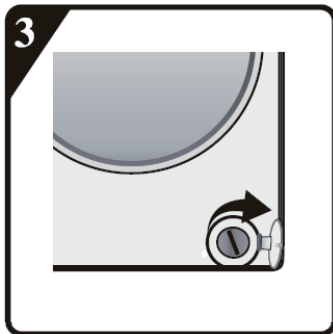

3 Breng de waterfilter opnieuw aan in het apparaat door het met de klok mee te draaien.

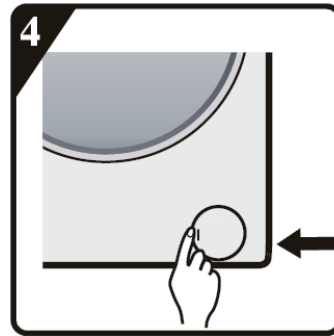

4 Sluit het deksel tot u een klik hoort.

PROBLEEMOPLOSSING

Problemen	Mogelijke oorzaak	Mogelijke oplossing
De wasmachine wordt niet ingeschakeld.	De deur is niet goed gesloten.	Sluit de deur op een juiste manier.
	Niet goed met de voeding verbonden.	Controleer de verbinding met de voeding.
	Stroomuitval	Controleer de voeding.
	Machine is niet ingeschakeld.	Schakel de machine in.
Wasmiddel blijft in het bakje achter na beëindiging van het programma.	Het gebruikte wasmiddel heeft een hoog schuimvermogen.	Gebruik alleen een gepast wasmiddel.
	Te veel wasmiddel gebruikt.	Doe minder wasmiddel in het wasmiddelbakje.
Wasmachine trilt of maakt veel lawaai.	Niet alle transportbouten zijn afgehaald.	Verwijder alle transportbouten.
	Wasmachine is op oneffen oppervlak geplaatst of staat niet waterpas.	Zorg dat de wasmachine op een vlak oppervlak en waterpas staat.
	Lading is hoger dan maximum capaciteit.	Doe minder wasgoed in de trommel.

De wasmachine voert geen water af en/of centrifugeert niet.	Afvoerslang is verstopt.	Verwijder de verstopping.
	De filter is verstopt	Verwijder de verstopping.
	Onbalans in wasgoed	Voeg kledingstukken toe of voer nogmaals een centrifugeprogramma uit.
Het wasresultaat is niet goed.	Uw wasgoed was te vuil voor het gekozen programma.	Selecteer een gepast programma.
	De hoeveelheid gebruikte wasmiddel is verkeerd.	Gebruik meer of minder wasmiddel volgens de aanwijzingen van de fabrikant.
	De maximum laadcapaciteit voor uw machine is overschreden.	Overschrijd de maximum capaciteit voor uw machine niet.
Het apparaat droogt niet of droogt niet goed.	Kraan is niet open gedraaid.	Draai de waterkraan open.
	De filter van de afvoerpomp is verstopt.	Zorg ervoor dat de filter van de afvoerpomp niet verstopt is.
	De machine is verkeerd gevuld.	Verminder de lading kleding.
	Verkeerde cyclusinstelling	Zorg ervoor dat u de juiste cyclus hebt ingesteld.

Foutcodes

Scherm	Oorzaak	Oplossing
F01	Storing op de waterinlaat	Controleer of de waterdruk te laag is. Controleer of de inlaatslang geknoopt is. Controleer of de inlaatfilter verstopt is. Controleer of de inlaatslang bevroren is. Na het verwijderen van de storing, druk op Départ/Pause .
F03	Storing op de afvoer	Controleer of de afvoerslang geknoopt is. Controleer of de waterfilter verstopt is. BELANGRIJK: Zorg dat het water is afgekoeld voordat u het afvoert.
F13	Storing op de deurvergrendeling	Start het programma 20 seconden en ontgrendel de deur om te controleren of deze gesloten is. Open of sluit het opnieuw. Na het verwijderen van de storing, druk op Départ/Pause .
F14	Storing op de deurontgrendeling	Druk op Départ/Pause . Het apparaat probeert de deur te openen. Het alarm wordt pas verwijderd wanneer de deur is ontgrendeld. Of draai de programmakiezer 3 seconden naar de positie Off (Uit) om de machine uit te schakelen. Kies het gewenste programma om de machine te starten en het alarm wordt verwijderd.
F24	Overstroming of te veel schuim	Verwijder de foutcode door te drukken op Départ/Pause en voer het water dan af. Selecteer en start het nodige programma.
Andere foutcodes	Elektronische module werkt niet	Draai de programmakiezer 3 seconden naar de positie Uit 
F04 tot F98	zoals het hoort.	om de machine uit te schakelen Na het verwijderen van de storing, druk op Départ/Pause .

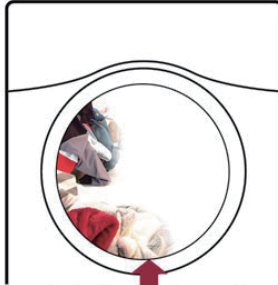
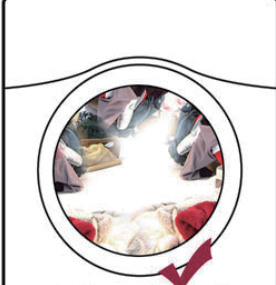
Unb	Onevenwicht alarm	 <p data-bbox="695 516 937 541">Onevenwichtige lading</p>	 <p data-bbox="1013 516 1214 541">Evenwichtig lading</p> <p data-bbox="678 594 1349 707">Als het wasgoed in elkaar wordt gewonden, scheid en herschik het wasgoed in de trommel. Als het wasgoed in de trommel te licht is, voeg twee of meer handdoeken toe.</p>
-----	-------------------	--	---

Als de storing opnieuw optreedt, haal de stekker uit het stopcontact en neem contact op met de klantenservice.

De deur in noodgevallen openen

Als de deur niet kan worden geopend vanwege een stroomuitval of andere speciale omstandigheid, kan de noodontgrendelingshendel op het luik van de afvoerpomp worden gebruikt om de deur te openen.

Voordat u de deur opent:



OPGELET!

Risico op brandwonden! Zorg ervoor dat de watertemperatuur niet te hoog is en de was niet heet is. Indien nodig, wacht totdat ze zijn afgekoeld.



OPGELET!

Verwondingsgevaar! Zorg ervoor dat de trommel niet draait. Indien nodig, wacht totdat de trommel stopt met draaien.

Ga als volgt te werk om de deur te openen:

1. Zorg dat het apparaat is uitgeschakeld en haal de stekker uit het stopcontact.
2. Open de klep van de afvoerpompfilter.
3. Trek de noodontgrendelingshendel omlaag en houd het in deze positie, en open tegelijkertijd de deur van het apparaat.
4. Haal het wasgoed eruit en sluit de deur van het apparaat.
5. Sluit de klep van de filter.

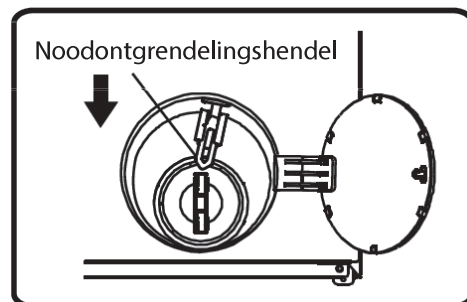

Productinformatieblad

GEDELEGEERDE VERORDENING (EU) 2019/2014 VAN DE COMMISSIE met betrekking tot de energie-etikettering van huishoudelijke wasmachines en huishoudelijke was-droogcombinaties

Naam van de leverancier of het handelsmerk: Etablissements Darty & fils © | TECNOLEC

Adres van de leverancier: 9 Rue des Bateaux-Lavois, 94200 Ivry-sur-Seine, France

Typeaanduiding: TECWD85AD

Algemene productparameters:

Parameter	Waarde		Parameter	Waarde	
Nominale capaciteit (kg)	Nominale capaciteit ^(b)	5,0	Afmetingen in cm	Hoogte	85
	Nominale wascapaciteit ^(a)	8,0		Breedte	60
				Diepte	54
Energie-efficiëntie-index	EEI _w ^(a)	51,6	Energie-efficiëntieklasse	EEI _w ^(a)	A
	EEI _{WD} ^(b)	67,0		EEI _{WD} ^(b)	D
Wasefficiëntie-index	I _w ^(a)	1,031	Spoeldoeltreffendheid (g/kg droog textiel)	I _R ^(a)	4,5
	J _w ^(b)	1,031		J _R ^(b)	4,5
Energieverbruik, uitgedrukt in kWh per cyclus, voor de wascyclus van de huishoudelijke was-droogcombinatie, met het programma "eco 40-60" bij een combinatie van volledige en gedeeltelijke ladingen. Het werkelijke energieverbruik hangt af van de manier waarop het apparaat wordt gebruikt.	0,469		Energieverbruik, uitgedrukt in kWh per cyclus, voor de cyclus wassen en drogen van de huishoudelijke wasdroogcombinatie bij een combinatie van volledige en gedeeltelijke ladingen. Het werkelijke energieverbruik hangt af van de manier waarop het apparaat wordt gebruikt.	2,660	
Waterverbruik, uitgedrukt in liters per cyclus, voor het programma "eco 40-60" bij een combinatie van volledige en gedeeltelijke ladingen. Het werkelijke waterverbruik hangt af van de manier waarop het apparaat wordt gebruikt en van de hardheid van het water	42		Waterverbruik, uitgedrukt in liters per cyclus, voor de cyclus wassen en drogen van de huishoudelijke wasdroogcombinatie bij een combinatie van volledige en gedeeltelijke ladingen. Het werkelijke waterverbruik hangt af van de manier waarop het apparaat wordt gebruikt en van de hardheid van het water.	80	
Maximumtemperatuur in het behandelde wasgoed (°C) voor de wascyclus van de huishoudelijke wasdroogcombinatie, met het programma "eco 40-60"	Nominale Wascapaciteit	34	Maximumtemperatuur in het behandelde wasgoed (°C) voor de wascyclus van de huishoudelijke wasdroogcombinatie, met de cyclus wassen en drogen	Nominale capaciteit	26
	Helft	30			Helft
	Kwart	25			

Centrifugesnelheid (rpm) ^(a)	Nominale Wascapaciteit	1400	Gewogen resterend vochtgehalte (%) ^(a)	53,0	
	Helft	1400			
	Kwart	1400			
Duur van het programma "eco 40-60" (u:min)	Nominale Wascapaciteit	3:26	Centrifuge-efficiëntieklasse ^(a)	B	
	Helft	2:48			
	Kwart	2:48			
Emissie van akoestisch luchtgeluid tijdens de centrifugefase van de wascyclus "eco 40-60" bij nominale wascapaciteit (dB(A) re 1 pW)	74		Duur van de cyclus wassen en drogen (u:min)	Nominale capaciteit	11:30
				Helft	8:00
Type	vrijstaand		Emissieklasse voor akoestisch luchtgeluid van de centrifugefase van het programma "eco 40-60" bij nominale wascapaciteit	B	
Uitstand (W) (indien van toepassing)	0,49		Stand-bystand (W) (indien van toepassing)	-	
Startvertraging (W) (indien van toepassing)	3,70		Netwerkgebonden stand-by (W) (indien van toepassing)	-	
Minimumduur van de door de leverancier geboden garantie: 24 maanden					
Dit product is zo ontworpen dat er zilverionen vrijkomen tijdens de wascyclus			NEE		
Aanvullende informatie:					
Link naar de website van de leverancier met de informatie zoals bedoeld in punt 9 van bijlage II bij Verordening (EU) 2019/2023: https://www.madocumentationreparation.com					

^(a) voor het programma "eco 40-60".

^(b) voor de cyclus wassen en drogen.

Over hoe de informatie over een model kan worden gevonden in de productendatabank :

Klik de link

<https://eprel.ec.europa.eu/screen/product/washerriers2019/2265203>

Waarden voor de volgende programma's:

Het programma "eco 40-60" bij nominale capaciteit	
(a) nominale capaciteit in kg:	8 kg
(b) programmaduur, uitgedrukt in uren en minuten:	3:26
(c) energieverbruik, uitgedrukt in kWh/cyclus:	0,740 kWh/cyclus
(d) waterverbruik, uitgedrukt in liters/cyclus:	55 L/cyclus
(e) maximumtemperatuur die voor minstens vijf minuten wordt bereikt in het wasgoed dat wordt behandeld tijdens de wascyclus, uitgedrukt in graden Celsius:	34°C
(f) resterend vochtgehalte na de wascyclus, uitgedrukt in een percentage van het watergehalte, en de centrifugesnelheid waarmee dit is bereikt:	53% 1400 rpm

Het programma "eco 40-60" bij halve nominale capaciteit	
(a) nominale capaciteit in kg:	4 kg
(b) programmaduur, uitgedrukt in uren en minuten:	2:48
(c) energieverbruik, uitgedrukt in kWh/cyclus:	0,372 kWh/cyclus
(d) waterverbruik, uitgedrukt in liters/cyclus:	40 L/cyclus
(e) maximumtemperatuur die voor minstens vijf minuten wordt bereikt in het wasgoed dat wordt behandeld tijdens de wascyclus, uitgedrukt in graden Celsius:	30°C
(f) resterend vochtgehalte na de wascyclus, uitgedrukt in een percentage van het watergehalte, en de centrifugesnelheid waarmee dit is bereikt:	53% 1400 rpm

Het programma "eco 40-60" een kwart van de nominale capaciteit	
(a) nominale capaciteit in kg:	2 kg
(b) programmaduur, uitgedrukt in uren en minuten:	2:48
(c) energieverbruik, uitgedrukt in kWh/cyclus:	0,250 kWh/cyclus
(d) waterverbruik, uitgedrukt in liters/cyclus:	30 L/cyclus
(e) maximumtemperatuur die voor minstens vijf minuten wordt bereikt in het wasgoed dat wordt behandeld tijdens de wascyclus, uitgedrukt in graden Celsius:	25°C
(f) resterend vochtgehalte na de wascyclus, uitgedrukt in een percentage van het watergehalte, en de centrifugesnelheid waarmee dit is bereikt:	53% 1400 rpm

Het programma op 20 °C bij de nominale capaciteit voor dit programma	
(a) nominale capaciteit in kg:	8 kg
(b) programmaduur, uitgedrukt in uren en minuten:	1:50
(c) energieverbruik, uitgedrukt in kWh/cyclus:	0,190 kWh/cyclus
(d) waterverbruik, uitgedrukt in liters/cyclus:	65 L/cyclus
(e) maximumtemperatuur die voor minstens vijf minuten wordt bereikt in het wasgoed dat wordt behandeld tijdens de wascyclus, uitgedrukt in graden Celsius:	21°C
(f) resterend vochtgehalte na de wascyclus, uitgedrukt in een percentage van het watergehalte, en de centrifugesnelheid waarmee dit is bereikt:	55% 1400 rpm

Een programma voor katoen bij een nominale temperatuur van minstens 60 °C (indien beschikbaar) bij de nominale capaciteit voor dit programma	
Coton 	
(a) nominale capaciteit in kg:	8 kg
(b) programmaduur, uitgedrukt in uren en minuten:	3:29
(c) energieverbruik, uitgedrukt in kWh/cyclus:	1,180 kWh/cyclus
(d) waterverbruik, uitgedrukt in liters/cyclus:	68 L/cyclus
(e) maximumtemperatuur die voor minstens vijf minuten wordt bereikt in het wasgoed dat wordt behandeld tijdens de wascyclus, uitgedrukt in graden Celsius:	57°C
(f) resterend vochtgehalte na de wascyclus, uitgedrukt in een percentage van het watergehalte, en de centrifugesnelheid waarmee dit is bereikt:	53% 1400 rpm

Een programma voor andere textielstoffen dan katoen of een combinatie van textielstoffen (indien beschikbaar) bij de nominale capaciteit voor dit programma 	
(a) nominale capaciteit in kg:	4 kg
(b) programmaduur, uitgedrukt in uren en minuten:	1:58
(c) energieverbruik, uitgedrukt in kWh/cyclus:	0,580 kWh/cyclus
(d) waterverbruik, uitgedrukt in liters/cyclus:	58 L/cyclus
(e) maximumtemperatuur die voor minstens vijf minuten wordt bereikt in het wasgoed dat wordt behandeld tijdens de wascyclus, uitgedrukt in graden Celsius:	38°C
(f) resterend vochtgehalte na de wascyclus, uitgedrukt in een percentage van het watergehalte, en de centrifugesnelheid waarmee dit is bereikt:	55% 1400 rpm

Een snelwasprogramma voor licht bevuild wasgoed (indien beschikbaar) bij de nominale capaciteit voor dit programma 	
(a) nominale capaciteit in kg:	1 kg
(b) programmaduur, uitgedrukt in uren en minuten:	0:30
(c) energieverbruik, uitgedrukt in kWh/cyclus:	0,310 kWh/cyclus
(d) waterverbruik, uitgedrukt in liters/cyclus:	18 L/cyclus
(e) maximumtemperatuur die voor minstens vijf minuten wordt bereikt in het wasgoed dat wordt behandeld tijdens de wascyclus, uitgedrukt in graden Celsius:	38°C
(f) resterend vochtgehalte na de wascyclus, uitgedrukt in een percentage van het watergehalte, en de centrifugesnelheid waarmee dit is bereikt:	55% 800 rpm

Een programma voor sterk bevuild wasgoed (indien beschikbaar) bij de nominale capaciteit voor dit programma 	
(a) nominale capaciteit in kg:	8 kg
(b) programmaduur, uitgedrukt in uren en minuten:	2:09
(c) energieverbruik, uitgedrukt in kWh/cyclus:	0,240 kWh/cyclus
(d) waterverbruik, uitgedrukt in liters/cyclus:	68 L/cyclus
(e) maximumtemperatuur die voor minstens vijf minuten wordt bereikt in het wasgoed dat wordt behandeld tijdens de wascyclus, uitgedrukt in graden Celsius:	20°C
(f) resterend vochtgehalte na de wascyclus, uitgedrukt in een percentage van het watergehalte, en de centrifugesnelheid waarmee dit is bereikt:	53% 1400 rpm

Voor huishoudelijke was-droogcombinaties: de cyclus wassen en drogen bij nominale capaciteit 	
(a) nominale capaciteit in kg:	5 kg
(b) programmaduur, uitgedrukt in uren en minuten:	11:30
(c) energieverbruik, uitgedrukt in kWh/cyclus:	3,170 kWh/cyclus
(d) waterverbruik, uitgedrukt in liters/cyclus:	92 L/cyclus
(e) maximumtemperatuur die voor minstens vijf minuten wordt bereikt in het wasgoed dat wordt behandeld tijdens de wascyclus, uitgedrukt in graden Celsius:	26°C

(f) resterend vochtgehalte na de wascyclus, uitgedrukt in een percentage van het watergehalte, en de centrifugesnelheid waarmee dit is bereikt:	2,90% 1400 rpm
--	-------------------

Voor huishoudelijke was-droogcombinaties: de cyclus wassen en drogen bij halve nominale capaciteit ☀️ Lavage et Séchage	
(g) nominale capaciteit in kg:	2,5 kg
(h) programmaduur, uitgedrukt in uren en minuten:	8:00
(i) energieverbruik, uitgedrukt in kWh/cyclus:	1,900 kWh/cyclus
(j) waterverbruik, uitgedrukt in liters/cyclus:	63 L/cyclus
(k) maximumtemperatuur die voor minstens vijf minuten wordt bereikt in het wasgoed dat wordt behandeld tijdens de wascyclus, uitgedrukt in graden Celsius:	26°C
(l) resterend vochtgehalte na de wascyclus, uitgedrukt in een percentage van het watergehalte, en de centrifugesnelheid waarmee dit is bereikt:	2,90% 1400 rpm

OPMERKING :

- Het programma "eco 40-60" geschikt is voor het reinigen van normaal bevuild katoenen wasgoed waarvan is aangegeven dat het op 40 °C of 60 °C kan worden gewassen, samen in dezelfde cyclus.
- Dit programma wordt gebruikt om na te gaan of de EU-regelgeving inzake ecologisch ontwerp wordt nageleefd.
- De programma's met lagere temperaturen en een langere duur over het algemeen het meest efficiënt zijn op het gebied van energieverbruik.
- De cyclus wassen en drogen geschikt is voor het reinigen van normaal bevuild katoenen wasgoed waarvan is aangegeven dat het op 40 °C of 60 °C kan worden gewassen, samen in dezelfde cyclus, dat deze cyclus geschikt is om dit wasgoed zodanig te drogen dat het onmiddellijk in een kast kan worden opgeborgen en dat dit programma wordt gebruikt om na te gaan of de EU-regelgeving inzake ecologisch ontwerp wordt nageleefd.
- Energie en water worden bespaard wanneer de huishoudelijke wasmachine wordt gevuld tot de door de fabrikant opgegeven capaciteit voor de respectieve programma's.
- De centrifugesnelheid een invloed heeft op het geluidsniveau en het resterende vochtgehalte: hoe hoger de centrifugesnelheid tijdens de centrifugefase, des te hoger het geluidsniveau en des te lager het resterende vochtgehalte.
- De waarden voor andere programma's dan het programma "eco 40-60" en de cyclus wassen louter indicatief zijn.

Voeding	220-240V~, 50Hz
Waterdruk	1750W (nominal vermogen) 1350W (droogkracht)
Kwaliteit van waterdicht	0,1 – 1 MPa
	IPX4

DIENST VOOR HERSTELLINGEN EN RESERVEONDERDELEN



Demonteer of herstel het apparaat niet zelf om het risico op een elektrische schok of persoonlijk letsel te vermijden.

Voor professionele herstellingen of het bestellen van reserveonderdelen, neem contact op met de klantenservice van FNAC DARTY.

Reserveonderdelen voor uw apparaten worden binnen 15 werkdagen na het ontvangen van de bestelling geleverd.

Beschikbaarheid van reserveonderdelen: ten minste tien jaar

Opgelet!

Alle apparaten hebben een garantie van 2 jaar.

De garantie geldt niet voor schade veroorzaakt door een verkeerde installatie, ongeoorloofde wijziging, zelf uitgevoerde of niet professionele herstellingen.

Neem contact met ons op:



www.darty.com



0978 970 970

24 uur
7 dagen per week



9 Rue des Bateaux-Lavois,
94200 Ivry-sur-Seine,
France

Vanden Borre
in alle vertrouwen

www.vandenborre.be



02 334 00 00

8u – 18u
Ma tot Zat



Slesbroekstraat 101
1600 Sint-Pieters-Leeuw
Belgium

VERWIJDERING



Als verantwoordelijke handelaar dragen we zorg voor het milieu.

We moedigen u aan om de juiste verwijderingsprocedure voor uw apparaat en verpakkingsmateriaal te volgen. Dit draagt bij tot het behoud van de natuurlijke rijkdommen door deze te recyclen zodat zowel de menselijke gezondheid en het milieu worden beschermd.

Gooi dit apparaat en de verpakking weg in overeenstemming met de geldende wetgeving en voorschriften.

Aangezien dit apparaat elektronische componenten bevat moet het apparaat en toebehoren aan het einde van hun levensduur afzonderlijk van het huisafval worden weggegooid.

Neem contact op met uw gemeente voor informatie over afdanking en recycling.

Lever het apparaat in bij het inzamelpunt van uw gemeente voor recycling. Bij sommige inzamelpunten kunt u het apparaat gratis inleveren.

We verontschuldigen ons voor enig ongemak veroorzaakt door kleine inconsistenties in deze gebruikershandleiding, die kunnen ontstaan door productverbetering of -ontwikkeling.

Etablissements Darty & fils ©,

9 Rue des Bateaux-Lavoirs, 94200 Ivry-sur-Seine, France 28/02/2025

PT

Índice

INSTRUÇÕES DE SEGURANÇA IMPORTANTES.....	1
VISTA PORMENORIZADA DO PRODUTO.....	5
INSTALAÇÃO.....	6
ANTES DE CADA LAVAGEM.....	9
LAVAGEM E SECAGEM.....	11
TABELA DOS PROGRAMAS.....	16
FUNÇÕES ADICIONAIS.....	19
LIMPEZA E MANUTENÇÃO.....	20
RESOLUÇÃO DE PROBLEMAS.....	23
FICHA DE INFORMAÇÃO DO PRODUTO	26
REPARAÇÃO E PEÇAS SOBRESSELENTES.....	31
ELIMINAÇÃO.....	32

Este produto foi fabricado e vendido sob a responsabilidade da Etablissements Darty et Fils (S.A.S). THOMSON e o logótipo da THOMSON são marcas comerciais usadas sob licença pela Etablissements Darty et Fils (S.A.S) – mais informações em www.thomson-brand.com . Todos os outros produtos, serviços, empresas, marcas comerciais, nomes comerciais ou do produto e logótipos referenciados pertencem aos respetivos proprietários.

INSTRUÇÕES DE SEGURANÇA IMPORTANTES

LEIA OS SEGUINTE AVISOS DE SEGURANÇA E AS INSTRUÇÕES CUIDADOSAMENTE ANTES DE UTILIZAR O APARELHO E GARDE PARA FUTURAS REFERÊNCIAS.

Avisos



- Leia as instruções.
- Este aparelho foi criado para uso doméstico e em aplicações semelhantes, como as seguintes:
 - Cozinhas em lojas, escritórios e outros ambientes de trabalho;
 - Casas de campo;
 - Por clientes em hotéis, motéis e outros ambientes do tipo residencial;
 - Ambientes do tipo residenciais com pequeno-almoço;
 - Áreas de uso comum em prédios.
- Se o fio da alimentação ficar danificado, deverá ser substituído pelo fabricante, o agente de reparação ou uma pessoa igualmente qualificada, de modo a evitar quaisquer perigos.
- Este aparelho pode ser usado por crianças com mais de 8 anos de idade e pessoas com capacidades físicas, sensoriais ou mentais reduzidas, ou falta de experiência e conhecimentos, se forem supervisionadas e ensinadas quanto à utilização do aparelho de um modo seguro, e compreenderem os perigos envolvidos.
As crianças não deverão brincar com o aparelho.
A limpeza e manutenção não deverão ser feitas por crianças sem supervisão.
- CUIDADO: Não ligue ao abastecimento de água quente.
- As aberturas não podem ser obstruídas por uma tapete.
- A pressão da água não pode ser inferior a 0.1 MPa nem superior a 1 MPa.
- Tem de usar o conjunto da mangueira fornecida com o aparelho. Não deverá reutilizar mangueiras antigas.
- As crianças com menos de 3 anos de idade deverão ser mantidas afastadas, a não ser que sejam constantemente supervisionadas.
- Para mais instruções detalhadas acerca do método de limpeza, consulte a secção “LIMPEZA E MANUTENÇÃO” na página 20-23.

- O peso máximo de material têxtil seco, em quilogramas, a utilizar no aparelho é de 8 kg (para o ciclo de lavagem) e de 5 kg (para o ciclo de lavagem e secagem).
- A máquina de secar não deve ser utilizada se tiverem sido utilizados produtos químicos industriais para a limpeza.
- O coletor de algodão tem de ser limpo frequentemente.
- Não se deve permitir a acumulação de algodão à volta da máquina de secar.
- É necessário prever uma ventilação adequada para evitar o refluxo de gases para o compartimento provenientes de aparelhos que queimam outros combustíveis, incluindo lareiras.
- Não seque os artigos não lavados na máquina de secar.
- Os artigos que foram sujos com substâncias como óleo alimentar, acetona, álcool, gasolina, querosene, tira-nódoas, aguarrás, ceras e removedores de cera devem ser lavados em água quente com uma quantidade extra de detergente antes de serem secos na máquina de secar.
- Artigos como espuma de borracha (espuma de látex), toucas de banho, têxteis impermeáveis, artigos com revestimento de borracha e roupas ou almofadas equipadas com almofadas de espuma de borracha não devem ser secos na máquina de secar.
- Os amaciadores de roupa, ou produtos semelhantes, devem ser utilizados de acordo com as instruções do amaciador.
- Remova todos os objetos dos bolsos, como isqueiros e fósforos.
- **AVISO: Nunca pare a máquina de secar antes do fim do ciclo de secagem, a menos que todos os objetos sejam rapidamente retirados e espalhados para que o calor se dissipe.**
- **AVISO: O aparelho não deve ser alimentado através de um dispositivo externo de ligação, como um temporizador, ou ligado a um circuito que seja ligado e desligado com regularidade por uma empresa de serviços públicos.**
- O ar de exaustão não deve ser descarregado para uma chaminé utilizada para a exaustão de fumos de aparelhos a gás ou outros combustíveis.
- Este aparelho não deve ser instalado atrás de uma porta que possa ser fechada, de uma porta de correr ou de uma porta com dobradiças do lado oposto ao da máquina de secar, de modo a impedir a abertura total da porta da máquina de secar.

Precauções de segurança

- O aparelho destina-se apenas a uso no interior.
- Mantenha os materiais de empacotamento do aparelho afastados das crianças, para evitar perigos.
- Não ligue o aparelho à alimentação com as mãos molhadas.
- Nunca toque no aparelho com as mãos ou pés molhados.
- No caso de falhas, primeiro retire a ficha da tomada e depois feche a torneira da água. Não tente repará-lo sozinho. Por favor, contacte um agente de reparação autorizado.
- Não exceda a capacidade máxima de carga.
- A porta de vidro fica muito quente durante o ciclo de lavagem. Mantenha as crianças e animais afastados do aparelho durante o funcionamento.
- Nunca force a abertura da porta durante o funcionamento do aparelho.
- Não deixe as crianças sem supervisão perto do aparelho, pois podem ficar presas dentro dele.
- Retire sempre a ficha da tomada e desligue o abastecimento de água após a utilização.
- Crianças e animais podem subir para dentro da máquina. Verifique a máquina antes de cada utilização.
- A ficha tem de permanecer facilmente acessível após a instalação do aparelho.
- Não lave artigos que tenham sido limpos, lavados, embebidos ou esfregados com substâncias combustíveis ou explosivas, como cera, óleo, tinta, gasolina, álcool, querosene e outros materiais inflamáveis. Isto pode resultar num incêndio ou explosão.
- O aparelho não deve ser instalado em casas de banho ou locais muito húmidos, nem em locais com gases explosivos ou cáusticos.

VISTA PORMENORIZADA DO PRODUTO

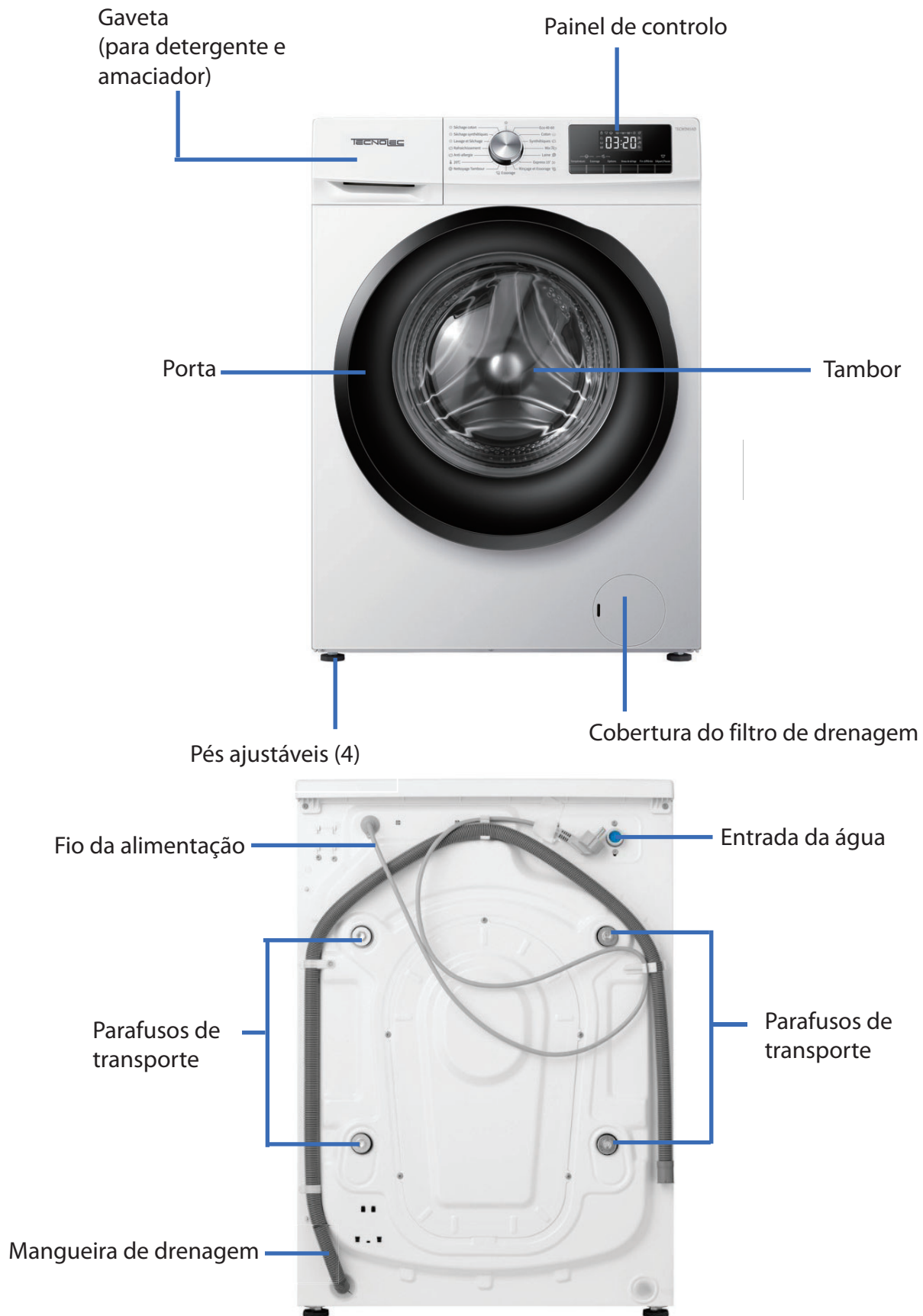

Acessórios



Tampas



Mangueira de entrada



Placa inferior



Dobra em U



Chave

Painel de controlo

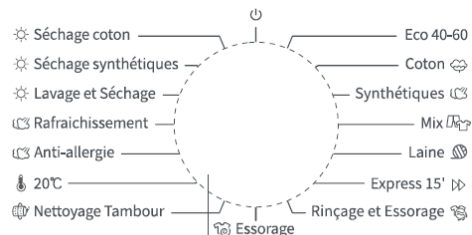

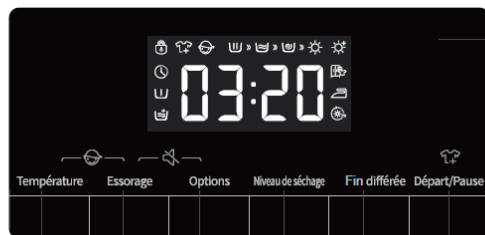

Seletor de programas



Visor

1 2 3 4 5 6





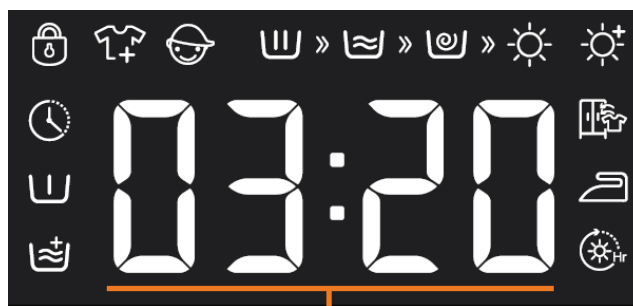

- 1 Botão da temperatura
- 2 Botão da centrifugação
- 3 Botão de opções
- 4 Botão do nível de secagem
- 5 Botão de fim do retardamento
- 6 Botão de Iniciar/Pausa

- 1 + 2  Função de bloqueio para crianças
- 2 + 3  Função de som
- 6  Função de recarga





Indicadores no visor



Visualização do tempo de lavagem, velocidade, código de erro, temperatura

					
Porta fechada	Recarga	Bloqueio para crianças	Fim do retardamento	Pré-lavagem	Enxaguamento extra

Símbolos do nível de secagem

			
Extra seco	Seco para arrumação no armário	Seco para engomar	Secagem programada

Os símbolos aparecem no visor quando a fase correspondente é definida.

	»		»		»	
Fase de lavagem		Fase de enxaguamento		Fase de centrifugação		Fase de secagem

INSTALAÇÃO

■ Remover o material de empacotamento

1. Retire a caixa de cartão e a esferovite.
2. Levante a máquina de lavar e retire o conjunto da base. São necessárias 2 ou mais pessoas.
3. Retire a fita que fixa o fio da alimentação e a mangueira de drenagem.



AVISO:

O material de empacotamento (películas, esferovite) pode ser perigoso para as crianças.

Existe um risco de sufocação! **Mantenha todo o material de empacotamento**

■ Retire os parafusos de transporte.

O aparelho vem com parafusos de transporte para evitar danos internos durante o transporte. O material de empacotamento e os parafusos de transporte têm de ser retirados antes de usar o aparelho.

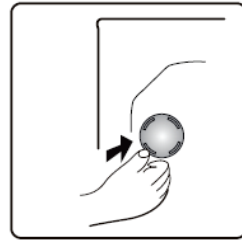
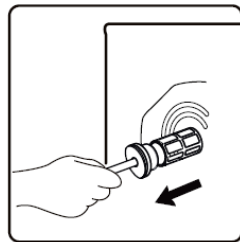
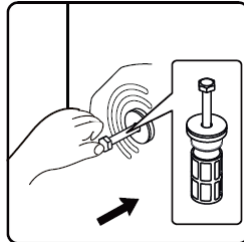
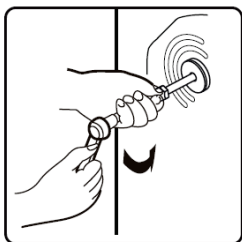

1. Use uma chave para rodar as cabeças dos parafusos no sentido inverso ao dos ponteiros do relógio até que os parafusos possam ser retirados parcialmente.
2. Pressione os parafusos de transporte para dentro para os libertar.
3. Retire os parafusos de transporte e os casquilhos de borracha puxando para fora.
4. Feche os orifícios usando as tampas fornecidas.

■ Posicionamento

Instale o aparelho numa superfície plana e dura.

Certifique-se de que a circulação do ar em redor do aparelho não é obstruída por carpetes, tapetes, etc.

Deixe, pelo menos, 2 cm de espaço livre de cada lado do aparelho.

Certifique-se de que o aparelho não fica em cima do fio da alimentação.

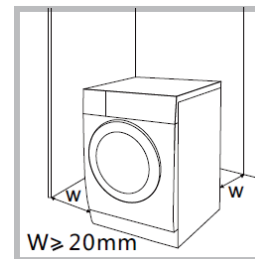

■ Requisitos do local de instalação

Antes de instalar o aparelho, deverá selecionar um local com as seguintes características:

- Superfície rígida, seca e nivelada
- Evite a exposição à luz direta do Sol
- Com ventilação suficiente
- A temperatura ambiente é superior a 0 °C.
- Mantenha afastado de fontes de calor, como aquecedores a carvão ou gás.

■ Nivelar o aparelho

Nivelar a máquina de lavar corretamente evita ruído e vibração excessivos.

Instale o aparelho numa superfície sólida e nivelada.

Se o piso estiver desnivelado, rode os pés ajustáveis conforme necessário.

- Nunca coloque cartões, blocos de madeira ou materiais semelhantes por baixo dos pés.

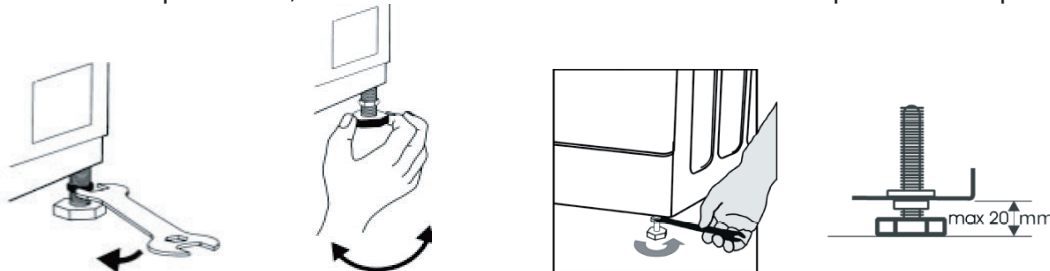

1. Desaperte as porcas de fixação com uma chave.
2. Rode os pés ajustáveis para ajustar a altura.
 - Certifique-se de que os quatro pés estão estáveis e assentes no chão. Depois, certifique-se de que o aparelho está perfeitamente nivelado (use um nível de bolha).
3. Aperte as porcas de fixação.

■ Instalar a cobertura inferior

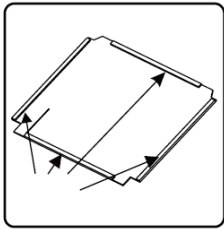

1. Retire o papel de suporte das fitas de dupla face nos quatro lados da placa inferior.

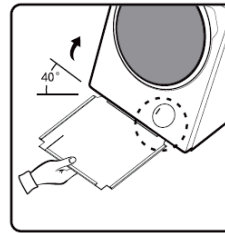

2. Incline o aparelho para trás (ângulo de inclinação : 40°) e insira a placa inferior.

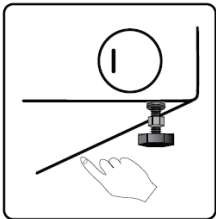

3. Pressione as fitas de dupla face para fixar a placa inferior no aparelho.

Atenção: Para obter um melhor desempenho no nível de ruído, certifique-se de que coloca a "Placa inferior de redução do ruído" conforme fornecida. Leia e siga o guia de instalação conforme indicado na placa de redução de ruído e no manual de instruções.

■ Ligação elétrica

A sua máquina de lavar funciona com 220-240V e 50Hz.

As ligações elétricas têm de ser efetuadas por um técnico qualificado, em conformidade com as normas de segurança locais.

A sua máquina de lavar tem de estar devidamente ligada à terra. Não nos responsabilizamos por quaisquer danos que possam ocorrer como resultado de uma utilização sem ligação correta à terra.

Não use uma extensão nem tomadas múltiplas.

O aparelho não pode ser alimentado através de um dispositivo externo de ligação, como um temporizador, ou ligado a um circuito ligado e desligado com regularidade.

Não retire a ficha da tomada se houver um gás inflamável por perto.

■ Ligar as mangueiras

Ligar a mangueira da alimentação da água



O aparelho tem de ser ligado ao abastecimento de água fria.

Certifique-se de que não há dobras na mangueira e que esta não tem pesos por cima.

1. Enrosque uma extremidade da mangueira de entrada na parte traseira do aparelho.

2. Ligue a outra extremidade da mangueira de entrada a uma torneira com uma rosca de 3/4".

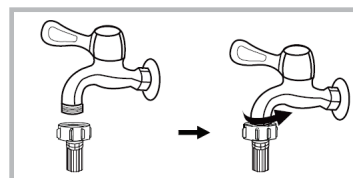
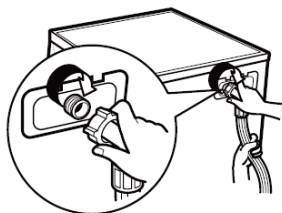

**NOTA:**

Após terminar a ligação, abra a torneira lentamente e certifique-se de que não há fugas. Não torça, aperte, modifique nem corte a mangueira.

Ligar a mangueira de drenagem

Para instalar a mangueira de drenagem, use um dos seguintes métodos.

Certifique-se de que a mangueira de drenagem não dobra, fica presa, é esmagada nem é esticada.

- Pressione a mangueira firmemente para um tubo de drenagem.

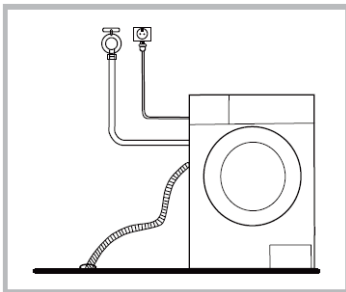

- Quando instalar a mangueira de drenagem num lavatório, fixe-a bem com um fio.

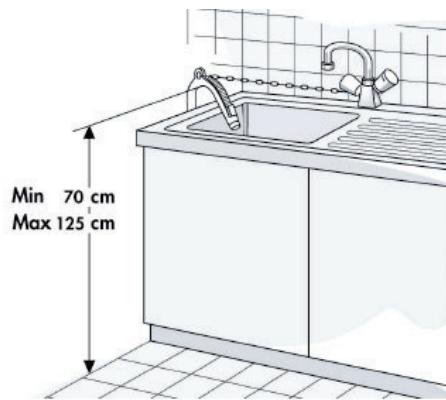
**NOTA:**

A mangueira de drenagem da água deverá ser montada a uma altura mínima de 70 cm e máxima de 125 cm do chão.

ANTES DE CADA LAVAGEM**Regras para separar a roupa**

- Tipo de tecido / símbolo na etiqueta de lavagem (algodão, fibras mistas, sintético, lá, artigos laváveis à mão).
- Cor
Separe os artigos de cor dos artigos brancos. Lave os artigos coloridos novos em separado.
- Tamanho
Lave artigos de diferentes tamanhos na mesma carga para melhorar a eficiência da lavagem e distribuição dos artigos no tambor.
- Artigos delicados
Lave artigos delicados em separado.
- Artigos de bebé (roupa de bebé, toalhas e lenços) deverão ser lavados em separado.
Se forem lavados com roupa de adultos, podem ficar infetados. Os tempos de enxaguamento deverão ser aumentados para garantir um enxaguamento e limpeza completos, e que não ficam restos de detergente.
- Sugerimos que os artigos que se mancham facilmente, como as meias brancas, golas e mangas, sejam lavados à mão antes de serem colocados na máquina de lavar roupa, para obter efeitos de lavagem mais ideais.

Esvaziar os bolsos



Verifique todos os bolsos para se certificar de que estão vazios. Artigos como pregos, molas do cabelo, canetas, moedas e chaves podem danificar o aparelho e as suas roupas.

Feche todos os fechos, botões e ganchos.

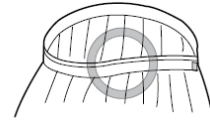
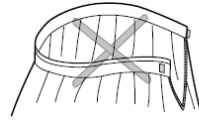

Feche os fechos, ganchos e fios, para se certificar de que estes artigos não ficam presos noutros artigos.

Ate todas as fitas ou cintos.

Detergente

Leia as instruções na embalagem do detergente ou outro agente para uma quantidade correta, dependendo da quantidade de roupa, grau de sujidade e dureza da água.

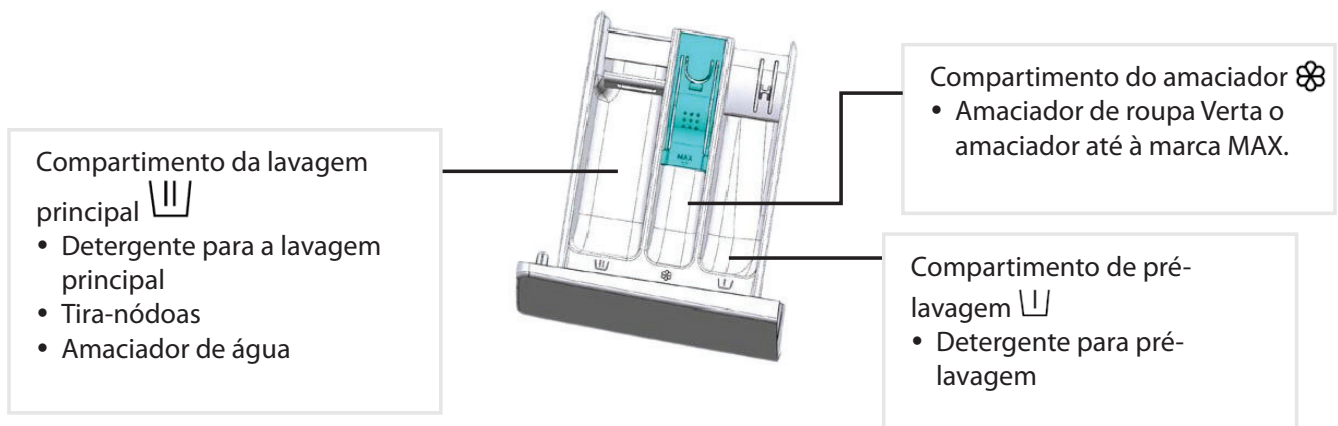

A escolha do detergente depende do seguinte:

- tipo de tecido (algodões, tecidos sintéticos de fácil manutenção, artigos delicados, lã).
Nota: Utilize apenas detergentes específicos para a lavagem da lã.
- Cor
- Temperatura de lavagem
- Grau e tipo de sujidade

Observações:

- Os eventuais resíduos esbranquiçados em tecidos escuros são causados por compostos insolúveis utilizados nos detergentes em pó modernos sem fosfatos. Se tal acontecer, sacuda ou escove o tecido ou utilize detergentes líquidos.
- Utilize apenas detergentes e amaciadores especificamente produzidos para máquinas de lavar roupa domésticas.
- Quando utilizar agentes descalcificantes, corantes ou branqueadores para a pré-lavagem, certifique-se de que são adequados para utilização em máquinas de lavar roupa domésticas. O descalcificante pode conter produtos que podem danificar a máquina de lavar roupa.
- Não utilize solventes (por exemplo, terebintina, benzeno). Não lave na máquina tecidos que tenham sido tratados com solventes ou líquidos inflamáveis.

- Guarde os detergentes e os aditivos num local seguro, seco e fora do alcance das crianças.
- Para evitar problemas de distribuição quando se utilizam detergentes em pó e líquidos altamente concentrados, utilize a bola ou o saco especial para detergente fornecido com o detergente e coloque-o diretamente no interior do tambor.

LAVAGEM E SECAGEM

Antes do primeiro ciclo de lavagem

Para eliminar a água residual usada durante o teste do fabricante, recomendamos que efetue um pequeno ciclo de lavagem sem roupa.

1. Abra a torneira.
2. Feche a porta.
3. Deite uma pequena quantidade de detergente no compartimento de dosagem manual do detergente líquido/pó para a fase de lavagem.
4. Selecione e inicie um programa curto.

Lavagem e secagem da roupa

1. Abra a porta para carregar os artigos no tambor.



NÃO SOBRECARREGUE o aparelho.
Tenha em conta os tamanhos de carga apresentados na tabela dos programas.
Sobrecarregar o aparelho tem influência nos resultados de lavagem.

2. Feche a porta.

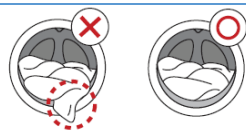

Certifique-se de que não ficam artigos presos entre a porta e o vedante da porta.

3. Adicionar o detergente e o amaciador.



Puxe a gaveta para fora.
Adicione o detergente e o amaciador nos compartimentos correspondentes.
Não encha demasiado.

4. Ligue o abastecimento de água.

5. Selecionar o programa pretendido.

Rode o seletor de programas para selecionar o programa pretendido. O visor indica o tempo de lavagem.

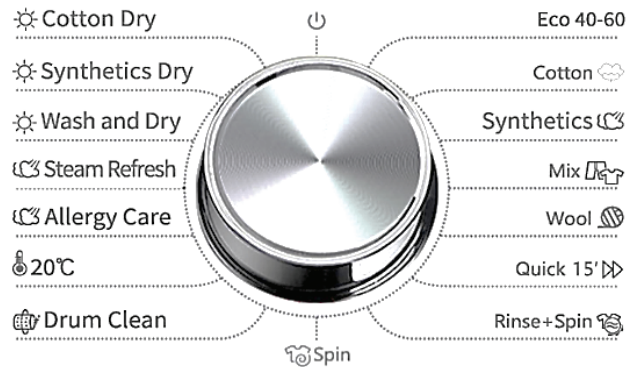

O seletor de programas serve igualmente para ligar ou desligar a máquina.

Para uma vista pormenorizada dos programas, consulte o quadro de programas.

6. Altere a temperatura, se necessário.

Prima repetidamente **Température** até definir a temperatura pretendida.

7. Alterar a velocidade de centrifugação, se necessário.

Prima repetidamente **Essorage** para definir a velocidade de centrifugação pretendida.

8. Selecionar opções, se necessário.

Prima repetidamente **Options** para selecionar a opção pretendida. As opções só estão disponíveis quando alguns programas são selecionados. O visor apresenta o símbolo correspondente ao selecionar a opção.

<p>U Pré-lavagem</p> <p>Selecione esta opção para lavar roupa muito suja. Antes da lavagem, o detergente para a roupa/pó de lavagem pode ser adicionado ao compartimento de pré-lavagem e o pó de lavagem deve ser adicionado ao compartimento de lavagem principal.</p>	<p>O diagrama mostra o seletor de programas com o visor centralizado exibindo o texto "Disponível para estes programas". Linhas pontilhadas conectam o visor aos seguintes ícones e textos:</p> <ul style="list-style-type: none">Alergy Care (ícone de gota)20°C (ícone de termômetro)Cotton (ícone de algodão)Synthetics (ícone de tecido)Mix (ícone de roupa mista)
---	--



Enxaguamento extra
Selecione esta opção para adicionar um ciclo de enxaguamento adicional para obter um melhor resultado de enxaguamento.



Disponível para estes programas

Allergy Care

20°C

Cotton

Synthetics

Mix

Wool

Quick 15'

Rinse+Spin

9. Selecionar o nível de secagem pretendido.

Prima repetidamente **Niveau de séchage** para selecionar o nível de secagem pretendido e O visor mostra o símbolo do nível definido:

 Extra seco: a roupa fica completamente seca

 Seco para arrumar no armário: roupa para guardar

 Seco para passar a ferro : roupa para engomar



Disponível para estes programas

Cotton Dry

Synthetics Dry

Allergy Care

20°C

Spin

Eco 40-60

Cotton

Synthetics

Mix

Rinse+Spin

O aparelho pode detetar o peso da roupa para ajustar automaticamente o tempo de secagem. Antes de secar, confirme se a roupa pode ser seca.

Não lavável - roupa seca / não seca

Roupa que não pode ser lavada nem seca





Produtos de couro e peles
(Pode ocorrer deformação.)

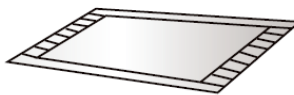

Rayon e seus produtos misturados
(Pode ocorrer descoloração ou deformação.)

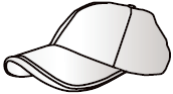

Almofadas grandes e grossas de borracha com carbamato na parte de trás
(Podem ocorrer danos ou avarias.)

 <p>Chapéus de material duro (Isto danifica a máquina e provoca avarias.)</p>	 <p>Almofadas, travesseiros, artigos com enchimento de algodão, espuma e outras matérias esponjosas, cobertura para tapetes (Podem ocorrer danos ou avarias.)</p>	<p>Outros Roupas enrugadas ou com relevo; tecidos de crepe; Roupas facilmente deformáveis (fatos, casacos, gravatas e vestidos, etc.); Roupas que se afofam facilmente (veludo, velveteen).</p>
--	--	---

Roupas que não podem ser secas

 <p>Qualquer peça de vestuário marcada com um gráfico (A roupa pode ficar danificada.)</p>	 <p>Roupa de lã (Pode ocorrer encolhimento e perda de pelo.)</p>	 <p>Collants, meias de ligas (Podem ocorrer danos ou deformações.)</p>	 <p>Calibragem da roupa</p>
 <p>Almofadas ou roupa com peles (Podem ser provocados danos ou avarias.)</p>	 <p>Colcha (Podem ocorrer danos ou avarias.)</p>	 <p>Roupa com rendas e bordados, fibra sintética nova (fibra muito fina) (Pode ocorrer deformação.)</p>	 <p>Seda</p>

Nota!

A roupa seca/não seca não lavável inclui, mas não se limita à roupa acima referida.

A roupa molhada que está a pingar não é adequada para secar, o que pode desencadear o alarme da máquina !

Programar a secagem

Quando o visor apresentar o

símbolo , prima repetidamente **Niveau de séchage** para definir o tempo adequado aos tecidos que pretende secar. O visor apresenta o tempo definido (30 minutos, 1 hora, 1,5 hora, 2 horas, 3 horas e 4 horas).



- Antes de secar separadamente, retire a roupa desidratada do tambor e coloque-a no tambor depois de a soltar.
- Quando se seca poucas roupas ou roupas leves, o tempo de secagem pode ser mais curto do que o tempo definido.
- Se a roupa lavada à mão necessitar de secagem, antes de a secar, selecione a centrifugação com velocidade elevada de acordo com o tipo de roupa. Recomenda-se a seleção dos programas "Centrifugação + Nível de secagem".
- No final do programa de secagem, a máquina funcionará durante um período de tempo de acordo com um determinado ritmo para soltar a roupa e reduzir os vincos.
- A secagem por sobrecarga pode afetar o efeito de secagem, enquanto a secagem excessiva pode provocar o enrugamento da roupa. Para as roupas de fibras químicas, como as camisas, etc., a secagem a ferro  deve ser selecionada.
- Se as roupas com diferentes tipos de tecidos forem secas em conjunto, o desempenho de secagem pode ser afetado. Por isso, é aconselhável separar corretamente a roupa antes de a secar.

10. Inicie um programa.

Prima **Départ/Pause**. A porta fica bloqueada e o visor apresenta o símbolo .

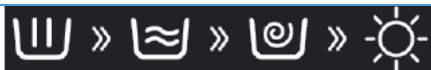



Estes símbolos indicam as fases do programa. O símbolo intermitente indica a fase que está a decorrer.

Pesagem automática

O visor apresenta "----" após iniciar um programa, indicando que está a pesar automaticamente. Ele ajusta automaticamente a duração do programa (horas e minutos) de acordo com o peso da roupa.

11. Faça uma pausa no programa e abra a porta, se necessário.

- Prima **Départ/Pause** para pausar um programa em execução.

- Se o nível ou a temperatura da água não for demasiado elevado, o símbolo de porta fechada  desaparecerá e o visor apresentará o símbolo de recarga  .
Pode abrir a porta, por exemplo, para adicionar mais roupa ou para retirar a roupa que tenha sido inserida por engano.
- Prima **Départ/Pause** para continuar com o programa.

12. Se necessário, altere um programa e as definições.

Para alterar as definições de um programa em execução:

- Rode o seletor de programas para a posição OFF (desligado)  durante 3 segundos.
- Selecione um novo programa e altere as definições.
- Selecione um novo programa e altere as definições.
- Prima **Départ/Pause** para iniciar um novo programa.



13. No final do ciclo, o visor apresenta a mensagem “End”.

14. Desligue a máquina rodando o seletor de programas para a posição OFF



15. Abra a porta e retire a roupa.













- A porta só pode ser aberta quando o símbolo  desaparecer.
- Certifique-se de que o símbolo  desaparece.
- Abra a porta e retire a roupa.
- Deixe a porta entreaberta para a esquerda, para que o interior do aparelho seque.















Feche a torneira.

TABELA DOS PROGRAMAS

Programa	Funções	Carga máxima (kg)	Temperaturas	Máx. velocidade de centrifugação (rpm)
Séchage Coton Secagem de algodão	Secagem	5	—	—
Séchage Synthétiques Secagem de sintéticos	Secagem	5	—	—
Lavage et séchage Lavar e secar	Lavar e secar	5	—	1400

Rafraichissement 	Secagem	2	—	—
Refrescar com vapor				
Anti-allergie 	Lavagem	4	40°C, 60°C, 90°C	1400
Cuidados com as alergias	Lavar e secar	4		
20°C	Secagem	8	20°C	1400
	Lavar e secar	5		
Nettoyage Tambour 	Lavar e secar	—	90°C	800
ECO 40-60	Lavagem	8	—	1400
	Lavar e secar	5		
Coton 	Lavagem	8	Frio, 20°C, 30°C, 40°C, 60°C, 90°C	1400
Algodão	Lavar e secar	5		
Synthétiques 	Lavagem	8	Frio, 20°C, 30°C, 40°C, 60°C	1200
	Sintéticos	Lavar e secar		5
Mix 	Lavagem	4	Frio, 20°C, 30°C, 40°C	1400
	Misto			
Laine 	Lavagem	2	Frio, 20°C, 30°C, 40°C	600
Lã				
Express 15' 	Lavagem	1	Frio, 20°C, 30°C, 40°C	800
Rápido 15'				
Rinçage et Essorage 	Lavagem	8	—	1400
	Limpar + Centrifugação	Lavar e secar		
Essorage 	Centrifugação	8	—	1400
	Centrifugação	Sentriugar e secar		

Programa	Descrição do programa (Tipo de carga e nível do solo)	Detergentes e aditivos		
		Pré-lavagem 	Main wash 	Softener 
Séchage Coton Secagem de algodão	A roupa húmida de algodão e linho pode ser seca depois de ser centrifugada.	—	—	—
Séchage Synthétiques Secagem de sintéticos	A roupa húmida de fibras químicas pode ser seca depois de ser centrifugada.	—	—	—
Lavage et séchage Lavar e secar	O ciclo de lavagem e secagem é capaz de limpar roupa de algodão com sujidade normal, declarada lavável a 40°C ou 60°C, no mesmo ciclo, e de a secar de modo a poder ser imediatamente guardada num armário, e que este programa é utilizado para avaliar a conformidade com a legislação de conceção	○	●	○

	ecológica da UE.			
Rafrachissement  Refrescar com vapor	É adequado para remover o cheiro peculiar (por exemplo, o cheiro de fumo/panela quente/churrasco, etc.) na roupa.	—	—	—
 Anti-allergie Cuidados com as alergias	Programa para extinguir eficazmente as bactérias nos têxteis. É adequado para a roupa dos bebés que são sensíveis à roupa.	○	●	○
20°C	Um ciclo de lavagem capaz de lavar roupa de algodão ligeiramente suja, a uma temperatura nominal de 20 °C.	○	●	○
 Nettoyage Tambour Limpeza do tambor	Programa para eliminar a sujidade e os resíduos bacterianos que se podem acumular na máquina após um período de utilização prolongado, especialmente quando são utilizadas regularmente lavagens a baixa temperatura.	—	—	—
ECO 40-60	Um ciclo de lavagem capaz de lavar roupa com sujidade normal que possa ser lavada a 40 °C ou 60 °C, junta no mesmo ciclo.	○	●	○
Coton  Cotton	Para a lavagem de roupa de algodão ou de linho com muita ou pouca sujidade Para peças de roupa muito sujas, seleccione a função "Pré-lavagem"	○	●	○
Synthétiques  Synthetics	Para tecidos sintéticos e misturas de algodão com sujidade moderada	○	●	○
Mix  Mix	Para cargas mistas de tecidos sintéticos e de algodão com sujidade moderada	○	●	○
Laine  Wool	Para lã lavável na máquina. (Consulte a etiqueta de lavagem anexada ao vestuário).	○	●	○
Express 15'  Quick 15'	Para lavar rapidamente peças de roupa pouco sujas	○	●	○
Rinçage et Essorage  Rinse + Spin	Este programa está predefinido para dois enxaguamentos e uma centrifugação.	—	—	○
Essorage  Spin	Centrifugação extra com velocidade de centrifugação seleccionável	—	—	—

● = dosagem necessária / ○ = opcional

FUNÇÕES ADICIONAIS

■ Função de atraso diferido



Pode usar esta função para definir o programa de lavagem para terminar mais tarde. O tempo do atraso diferido pode ser selecionado entre 1 e 24 horas em incrementos de 1 hora.

1. Selecione um programa.
2. Prima repetidamente **Fin différée** para selecionar a hora de fim desejada.
 - As horas apresentadas indicam a hora a que o programa de lavagem termina.
 - O visor apresenta o símbolo .
3. Prima **Départ/Pause** para iniciar o programa.
 - A máquina começa a contagem decrescente.

Por exemplo, se a duração do programa for superior a 2 horas, a função de final diferido mínima tem de começar a partir de 3 horas.

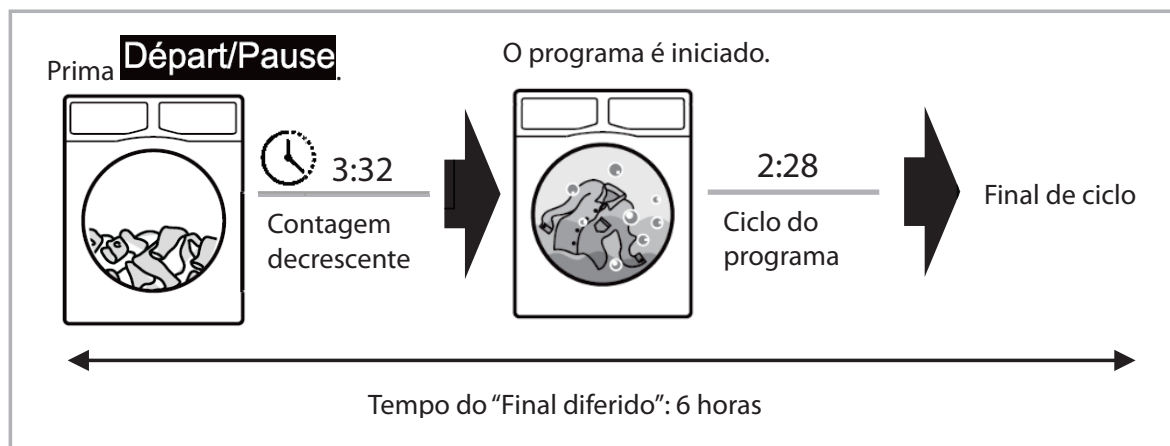
Se a duração do programa selecionado for 2:28 horas e definir o "Final diferido" para 6 horas, isso significa que o seu programa de lavagem termina em 6 horas.



Se pretender anular esta função antes de iniciar o programa, prima repetidamente **Fin différée** até o símbolo  desaparecer do visor. Para cancelar esta função depois de iniciar o programa, desligue a máquina rodando o seletor de programas para a posição OFF .

■ Função de som

Esta função permite ligar ou desligar o som produzido ao premir os botões ou ao rodar o seletor de programas.

- Prima e mantenha premido **Essorage** e **Options** simultaneamente durante cerca de 2 segundos até o visor apresentar "BEEP OFF", indicando que o som está desligado.

- Para desativar esta função, prima sem soltar **Essorage** e **Options** simultaneamente durante cerca de 2 segundos. O visor mostra "bEEp oN".

■ Função de bloqueio para crianças

Para reforçar a segurança das crianças, esta máquina está equipada com a função de bloqueio para crianças.

Quando o programa começar, prima sem soltar **Température** e **Essorage** simultaneamente durante 2 segundos. O visor apresenta o símbolo  indicando que a função está ativada. Quando a função é ativada, todos os botões de função são bloqueados.

Para desativar esta função, prima sem soltar **Température** e **Essorage** simultaneamente durante 2 segundos novamente. O símbolo  desaparece do visor.

- Quando se desliga a máquina, rodando o seletor de programas para a posição OFF  a função de bloqueio para crianças é desativada.
- Após o fim do programa, o bloqueio para crianças é automaticamente desbloqueado.

LIMPEZA E MANUTENÇÃO



AVISO:

Desligue sempre o aparelho da alimentação e feche a água da torneira antes de proceder à limpeza e manutenção.

■ Limpar a estrutura da máquina

Limpe com um pano suave ligeiramente embebido em água.

Não use produtos de limpeza químicos ou abrasivos.

Retire imediatamente os resíduos do agente de lavagem e de limpeza.

■ Limpar o tambor

A ferrugem no interior do tambor causada por artigos de metal deverá ser eliminada imediatamente com detergentes sem cloro. Nunca use lâ de aço para limpar o tambor!

Para eliminar o calcário do tambor, ative o ciclo de limpeza do tambor com o agente de eliminação do calcário de acordo com as instruções do fabricante para uma dosagem correta do detergente.

■ Limpeza do vedante da porta e vidro

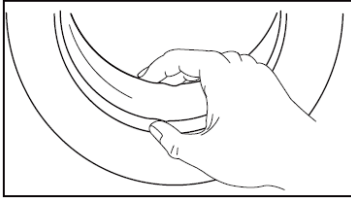

Limpe o vidro e vedante após cada lavagem, para eliminar o linho e manchas. Se o linho se acumular, isso pode dar origem a derrames.

Retire moedas, botões e outros objetos do vedante após cada lavagem.

Limpe o vedante da porta e o vidro todos os meses para garantir um funcionamento normal da máquina.

■ Limpeza do filtro de entrada



NOTA:

Limpe o filtro de entrada se a água não for fornecida corretamente.

Se a água for muito dura ou contiver vestígios de depósitos de calcário, o filtro de entrada de água pode estar obstruído. Recomendamos que limpe regularmente o filtro de entrada.

1. Feche a torneira da água e desenrosque a mangueira de entrada.

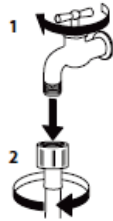

2. Limpe cuidadosamente o filtro de rede na extremidade da mangueira com uma escova fina.



3. Desenrosque a mangueira de entrada na parte traseira do aparelho à mão. Retire o filtro de rede da válvula na parte traseira do aparelho com um alicate, e limpe-o cuidadosamente com água corrente.

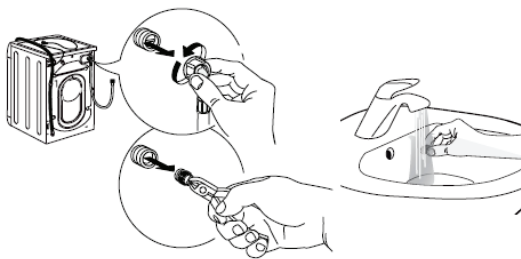

4. Volte a colocar o filtro de rede no aparelho. Ligue a mangueira de entrada na torneira da água e no aparelho. Abra a torneira da água e certifique-se de que todas as ligações estão apertadas.

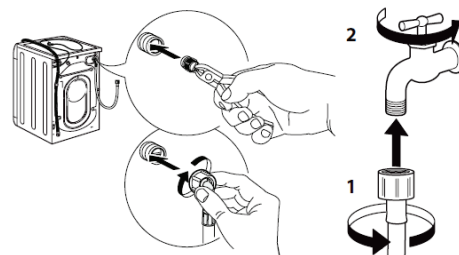

■ Limpar a gaveta do detergente



NOTA:

Recomenda-se que a gaveta do detergente seja limpa regularmente. Nunca utilize produtos de limpeza químicos ou abrasivos.

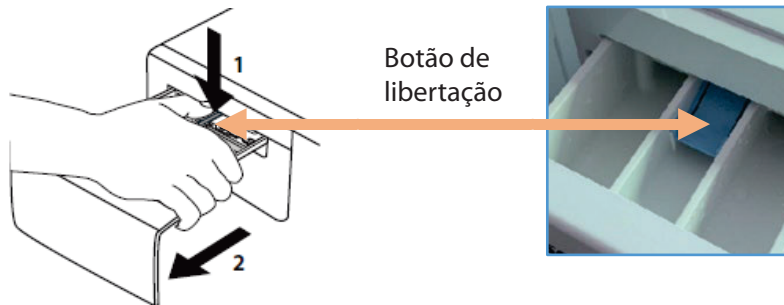

1. Retire a gaveta premindo o botão de desbloqueio e puxando ao mesmo tempo a gaveta para fora do aparelho.
2. Limpe todas as peças sob água corrente com uma escova macia, removendo todos os resíduos de detergente ou amaciador.
3. Limpe o encaixe da gaveta no aparelho com uma escova macia.
4. Volte a instalar a gaveta e empurre-a para a posição correta.

■ Limpeza do filtro da bomba de drenagem

O filtro da bomba de drenagem recolhe pequenos objetos deixados na roupa. Certifique-se regularmente de que o filtro está limpo, para garantir um funcionamento suave da sua máquina.



AVISO:

Tenha cuidado com a drenagem caso a água esteja quente. Permita à água arrefecer antes de limpar o filtro da bomba de drenagem. Risco de escaldões!

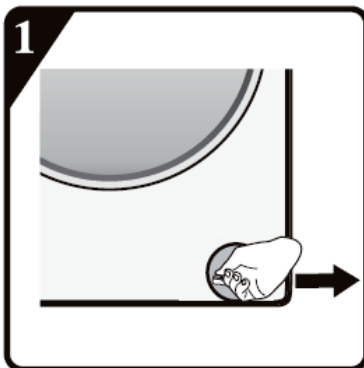

Prima a patilha da tampa para abrir a tampa.

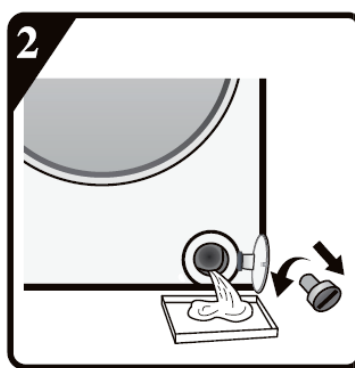

Coloque um recipiente baixo e largo por baixo do filtro da água. Rode lentamente o filtro no sentido inverso ao dos ponteiros do relógio até que toda a água tenha saído.

- Quando o recipiente estiver cheio, feche o filtro da água, rodando-o no sentido dos ponteiros do relógio. Esvazie o recipiente. Repita o procedimento até que toda a água tenha sido drenada.

Retire o filtro da água e limpe-o com água corrente e uma escova suave.

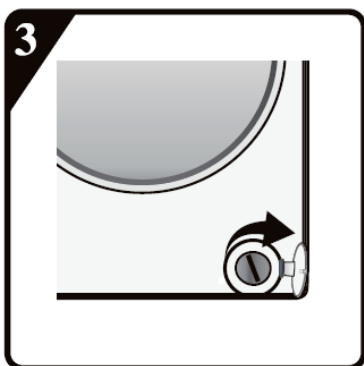

Volte a inserir o filtro da água no aparelho, rodando-o no sentido dos ponteiros do relógio.

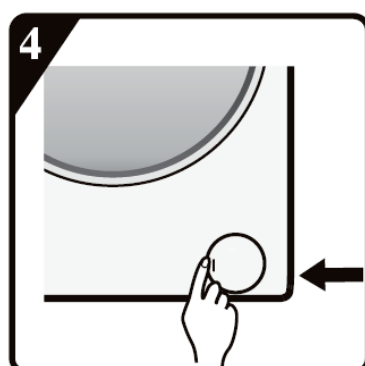

Feche a cobertura até ouvir um clique.

RESOLUÇÃO DE PROBLEMAS

Problemas	Possíveis Causas	Possíveis Soluções
A máquina de lavar não começa a funcionar.	A porta não está bem fechada.	Feche bem a porta.
	Ligação à alimentação incorreta.	Verifique a ligação à alimentação.
	Falha de eletricidade.	Verifique a alimentação.
	A máquina não foi ligada.	Ligue a máquina.
O detergente permanece na gaveta após o programa ter terminado.	O detergente não é do tipo fraco em bolhas de sabão.	Certifique-se de que o detergente é o adequado.
	Utilização excessiva de detergente.	Diminua a quantidade de detergente na gaveta do detergente.
A máquina de lavar vibra ou faz muito barulho.	Não retirou todos os parafusos de transporte.	Retire todos os parafusos de transporte.
	A máquina de lavar encontra-se numa superfície desnivelada ou não está nivelada.	Certifique-se de que a máquina de lavar está numa superfície nivelada e que a própria máquina está nivelada.
	A carga da máquina está acima da sua capacidade máxima.	Diminua a quantidade de roupa no tambor.
A máquina de lavar não drena e/ou não faz a centrifugação.	A mangueira de drenagem está bloqueada.	Desbloqueie a mangueira de drenagem.
	O filtro está bloqueado.	Desbloqueie o filtro.
	Desequilíbrio das peças de roupa.	Adicione roupa ou execute novamente o programa de centrifugação.
O resultado de lavagem não é bom.	A sua roupa estava muito suja para o programa selecionado.	Selecione um programa adequado.
	A quantidade de detergente usada não é a adequada.	Use mais ou menos detergente, seguindo as instruções do fabricante.
	Colocou na sua máquina	Não exceda a capacidade

	roupas que excedem a capacidade máxima.	máxima da sua máquina.
O aparelho não seca ou não seca corretamente.	A torneira não está ligada.	Ligue a torneira da água.
	O filtro da bomba de drenagem está bloqueado.	Verifique se o filtro da bomba de drenagem não está entupido.
	Máquina carregada incorretamente	Reduza a carga da roupa.
	Definição incorreta do ciclo	Certifique-se de que definiu o ciclo correto.

Códigos de erro

Visor	Causa	Solução
F01	Falha na entrada de água	Verifique se a pressão da água é demasiado baixa. Verifique se a mangueira de entrada está com nós. Verifique se o filtro de entrada está bloqueado. Verifique se a mangueira de entrada está congelada. Depois de eliminada a avaria, prima Départ/Pause .
F03	Falha na drenagem	Verifique se a mangueira de drenagem está com nós. Verifique se o filtro de água está bloqueado. IMPORTANTE: Certifique-se de que a água arrefeceu antes de esvaziar o aparelho.
F13	Falha no fecho da porta	Inicie o programa durante 20 segundos e destranque a porta para verificar se a porta está fechada. Abra ou feche novamente. Depois de eliminada a avaria, prima Départ/Pause .
F14	Falha no desbloqueio da porta	Prima Départ/Pause . O aparelho tenta abrir a porta. O alarme só será retirado quando a porta for destrancada. Ou rode o seletor de programas para a posição OFF durante 3 segundos para desligar a máquina. Selecione o programa desejado para pôr a máquina em funcionamento e o alarme será eliminado.
F24	Transbordo ou demasiada espuma	Remova o código de erro premindo Départ/Pause e, em seguida, drene a água. Selecione e inicie o programa pretendido.
Outros códigos de erro F04 a F98	Falha do módulo eletrónico.	Rode o seletor de programas para a posição OFF  durante 3 segundos para desligar a máquina. Depois de eliminada a avaria, prima Départ/Pause .

Unb	Alarme de desequilíbrio	 <p data-bbox="792 447 1008 478">Unbalanced Load</p> <p data-bbox="1149 447 1338 478">Balanced Load</p> <p data-bbox="740 516 1398 579">Se a roupa ficar enrolada, separe e reorganize a carga de roupa.</p> <p data-bbox="740 583 1398 646">Se a roupa no tambor for demasiado leve, adicione duas ou mais toalhas.</p>
-----	-------------------------	--

Se a avaria voltar a ocorrer, desligue o aparelho da tomada e contacte o serviço pós-venda.

Abertura de emergência da porta

No caso de falha em abrir a porta devido a uma falha de eletricidade ou outras circunstâncias especiais, o gatilho de desbloqueio de emergência da porta na porta da bomba de drenagem pode ser usado para uma abertura de emergência.

Antes de abrir a porta:



CUIDADO!

Risco de queimaduras! Certifique-se de que a temperatura da água não é demasiado alta e que as peças de vestuário não estão quentes. Se necessário, espere até que arrefeçam.



CUIDADO!

Existe o risco de ferimentos! Certifique-se de que o tambor não está a rodar. Se necessário, espere que o tambor pare de rodar.

Para abrir a porta, proceda do seguinte modo:

1. Certifique-se de que o aparelho está desligado e a ficha foi retirada da tomada.
2. Abra a cobertura do filtro da bomba de drenagem.
3. Mantenha o gatilho de desbloqueio de emergência pressionado para baixo e, em simultâneo, abra a porta do aparelho.
4. Retire as peças de vestuário e feche a porta do aparelho.
5. Feche a cobertura do filtro.

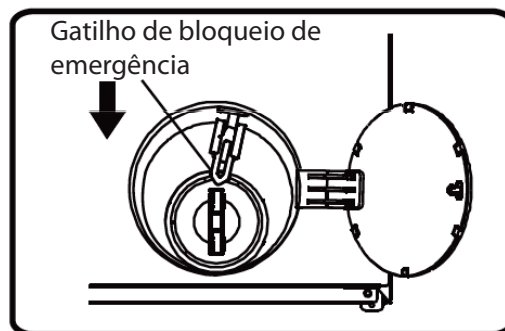

Ficha de informação do produto

REGULAMENTO DELEGADO (UE) 2019/2014 DA COMISSÃO respeitante à etiquetagem energética das máquinas de lavar roupa para uso doméstico e das máquinas combinadas de lavar e secar roupa para uso doméstico

Marca comercial ou nome do fornecedor: Etablissements Darty & fils © | TECNOLEC

Endereço do fornecedor: 9 Rue des Bateaux-Lavoirs, 94200 Ivry-sur-Seine, France

Identificador de modelo: TECWD85AD

Parâmetros gerais do produto:

Parâmetro	Valor		Parâmetro	Valor	
Capacidade nominal(kg)	Capacidade nominal ^(b)	5,0	Dimensões em cm	Altura	85
	Capacidade nominal de lavagem ^(a)	8,0		Largura	60
				Profundidade	54
Índice de eficiência energética	EEl _w ^(a)	51,6	Classe de eficiência energética:	EEl _w ^(a)	A
	EEl _{wd} ^(b)	67,0		EEl _{wd} ^(b)	D
Índice de eficiência de lavagem	I _w ^(a)	1,031	Eficácia de enxaguamento (g/kg de tecido seco)	I _R ^(a)	4,5
	J _w ^(b)	1,031		J _R ^(b)	4,5
Consumo de energia em kWh por ciclo, para o ciclo de lavagem da máquina de lavar e secar roupa doméstica, utilizando o programa eco 40-60 com uma combinação de cargas completas e parciais. O atual consumo de energia depende do modo como o aparelho é utilizado.	0,469		Consumo de energia em kWh por ciclo, para o ciclo de lavagem e secagem da máquina de lavar e secar roupa doméstica com uma combinação de cargas completas e meias cargas. O atual consumo de energia depende do modo como o aparelho é usado.	2,660	
Consumo de água em litros por ciclo, para o programa eco 40-60 com uma combinação de cargas completas e parciais. O atual consumo de água depende do modo como o aparelho é utilizado e da	42		Consumo de água em litros por ciclo, para o ciclo de lavagem e secagem da máquina de lavar e secar roupa doméstica, com uma combinação de cargas completas e meias cargas. O atual consumo de água depende do modo como o aparelho é usado e da dureza da água.	80	

dureza da água.					
Temperatura máxima no interior do têxtil tratado (°C) para o ciclo de lavagem da máquina de lavar e secar roupa doméstica, utilizando o programa eco 40-60	Capacidade nominal de lavagem	34	Temperatura máxima no interior do têxtil tratado (°C) para o ciclo de lavagem da máquina de lavar e secar roupa doméstica, utilizando o ciclo de lavagem e secagem	Capacidade nominal	26
	Metade	30		Metade	26
	Trimestre	25			
Velocidade de centrifugação (rpm) ^(a)	Capacidade nominal de lavagem	1400	Teor de humidade residual ponderada (%) ^(a)	53,0	
	Metade	1400			
	Trimestre	1400			
Duração do programa Eco 40-60 (h:min)	Capacidade nominal de lavagem	3:36	Classe de eficiência energética centrifugação-secagem ^(a)	B	
	Metade	2:48			
	Trimestre	2:48			
Emissões de ruído acústico aéreo durante a fase de centrifugação para o ciclo de lavagem eco 40-60 à capacidade de lavagem nominal 1 dB(A) re 1 pW	74		duração do ciclo de lavagem e secagem (h:min)	Capacidade nominal	11:30
				Metade	8:00
Tipo	De instalação livre		Classe de emissão de ruído acústico aéreo para a fase de centrifugação do programa eco 40-60 à capacidade nominal de lavagem	B	
Modo desligado (W) (Se aplicável)	0,49		Modo inativo (W) (Se aplicável)	-	
Início diferido (W) (Se aplicável)	3,70		Inativo em rede (W) (Se aplicável)	-	
Duração mínima da garantia do fornecedor: 24 meses					
Produto preparado para libertar iões de prata no ciclo de lavagem			NÃO		
Informações adicionais:					
Hiperligação para o sítio Web do fornecedor onde se encontram as informações previstas no anexo II, ponto 9, do Regulamento (UE) 2019/2023: https://www.madocumentationreparation.com					

^(a) para o programa «eco 40-60».

^(b) para o ciclo «lavar e secar».

Para saber a informação do modelo na base de dados do produto:

Clique no link

<https://eprel.ec.europa.eu/screen/product/washerdryers2019/2265203>

Valores para os seguintes programas:

O programa eco 40-60 à capacidade nominal	
(a) capacidade nominal em kg:	8 kg
(b) duração do programa, expressa em horas e minutos:	3:26
(c) consumo de energia, expresso em kWh/ciclo:	0,740 kWh/ciclo
(d) consumo de água, expresso em litros/ciclo:	55 L/ciclo
(e) temperatura máxima atingida durante um mínimo de 5 minutos no interior da roupa a tratar durante o ciclo de lavagem, expressa em graus centígrados:	34° C
(f) teor de humidade remanescente após o ciclo de lavagem, expresso em percentagem do teor de água, e a velocidade de rotação a que foi alcançado:	53% 1400 rpm

O programa eco 40-60 a metade da capacidade nominal	
(a) capacidade nominal em kg:	4 kg
(b) duração do programa, expressa em horas e minutos:	2:48
(c) consumo de energia, expresso em kWh/ciclo:	0,372 kWh/ciclo
(d) consumo de água, expresso em litros/ciclo:	40 L/ciclo
(e) temperatura máxima atingida durante um mínimo de 5 minutos no interior da roupa a tratar durante o ciclo de lavagem, expressa em graus centígrados:	30°C
(f) teor de humidade remanescente após o ciclo de lavagem, expresso em percentagem do teor de água, e a velocidade de rotação a que foi alcançado:	53% 1400 rpm

O programa eco 40-60 a um quarto da capacidade nominal	
(a) capacidade nominal em kg:	2 kg
(b) duração do programa, expressa em horas e minutos:	2:48
(c) consumo de energia, expresso em kWh/ciclo:	0,250 kWh/ciclo
(d) consumo de água, expresso em litros/ciclo:	30 L/ciclo
(e) temperatura máxima atingida durante um mínimo de 5 minutos no interior da roupa a tratar durante o ciclo de lavagem, expressa em graus centígrados:	25° C
(f) teor de humidade remanescente após o ciclo de lavagem, expresso em percentagem do teor de água, e a velocidade de rotação a que foi alcançado:	53% 1400 rpm

O programa de 20°C à capacidade nominal para este programa	
(a) capacidade nominal em kg:	8 kg
(b) duração do programa, expressa em horas e minutos:	1:50
(c) consumo de energia, expresso em kWh/ciclo:	0,190 kWh/ciclo
(d) consumo de água, expresso em litros/ciclo:	65 L/ciclo
(e) temperatura máxima atingida durante um mínimo de 5 minutos no interior da roupa a tratar durante o ciclo de lavagem, expressa em graus centígrados:	21° C

(f) teor de humidade remanescente após o ciclo de lavagem, expresso em percentagem do teor de água, e a velocidade de rotação a que foi alcançado:	55% 1400 rpm
--	-----------------

Um programa de algodão a uma temperatura nominal igual ou superior a 60°C (se existir) à capacidade nominal para esse programa 	
(a) capacidade nominal em kg:	8 kg
(b) duração do programa, expressa em horas e minutos:	3:29
(c) consumo de energia, expresso em kWh/ciclo:	1,180 kWh/ciclo
(d) consumo de água, expresso em litros/ciclo:	68 L/ciclo
(e) temperatura máxima atingida durante um mínimo de 5 minutos no interior da roupa a tratar durante o ciclo de lavagem, expressa em graus centígrados:	57 °C
(f) teor de humidade remanescente após o ciclo de lavagem, expresso em percentagem do teor de água, e a velocidade de rotação a que foi alcançado:	53% 1400 rpm

Um programa para outros têxteis que não o algodão ou uma mistura de têxteis (se existir) à capacidade nominal para este programa 	
(a) capacidade nominal em kg:	4 kg
(b) duração do programa, expressa em horas e minutos:	1:58
(c) consumo de energia, expresso em kWh/ciclo:	0,580 kWh/ciclo
(d) consumo de água, expresso em litros/ciclo:	58 L/ciclo
(e) temperatura máxima atingida durante um mínimo de 5 minutos no interior da roupa a tratar durante o ciclo de lavagem, expressa em graus centígrados:	38°C
(f) teor de humidade remanescente após o ciclo de lavagem, expresso em percentagem do teor de água, e a velocidade de rotação a que foi alcançado:	55% 1400 rpm

Um programa para a lavagem rápida de roupa pouco suja (se existir) à capacidade nominal para este programa 	
(a) capacidade nominal em kg:	1 kg
(b) duração do programa, expressa em horas e minutos:	0:30
(c) consumo de energia, expresso em kWh/ciclo:	0,310 kWh/ciclo
(d) consumo de água, expresso em litros/ciclo:	18 L/ciclo
(e) temperatura máxima atingida durante um mínimo de 5 minutos no interior da roupa a tratar durante o ciclo de lavagem, expressa em graus centígrados:	38°C
(f) teor de humidade remanescente após o ciclo de lavagem, expresso em percentagem do teor de água, e a velocidade de rotação a que foi alcançado:	55% 800 rpm

Um programa para têxteis muito sujos (se existir) à capacidade nominal para este programa 	
(a) capacidade nominal em kg:	8 kg
(b) duração do programa, expressa em horas e minutos:	2:09
(c) consumo de energia, expresso em kWh/ciclo:	0,240 kWh/ciclo
(d) consumo de água, expresso em litros/ciclo:	68 L/ciclo
(e) temperatura máxima atingida durante um mínimo de 5 minutos no interior	20°C

da roupa a tratar durante o ciclo de lavagem, expressa em graus centígrados:	
(f) teor de humidade remanescente após o ciclo de lavagem, expresso em percentagem do teor de água, e a velocidade de rotação a que foi alcançado:	53% 1400 rpm

Para as máquinas de lavar e secar roupa domésticas: o ciclo de lavagem e secagem à capacidade nominal  Lavage et Séchage	
(a) capacidade nominal em kg:	5 kg
(b) duração do programa, expressa em horas e minutos:	11:30
(c) consumo de energia, expresso em kWh/ciclo:	3,170 kWh/ciclo
(d) consumo de água, expresso em litros/ciclo:	92 L/ciclo
(e) temperatura máxima atingida durante um mínimo de 5 minutos no interior da roupa a tratar durante o ciclo de lavagem, expressa em graus centígrados:	26°C
(f) teor de humidade remanescente após o ciclo de lavagem, expresso em percentagem do teor de água, e a velocidade de rotação a que foi alcançado:	2,90% 1400 rpm

Para as máquinas de lavar e secar roupa domésticas: o ciclo de lavagem e secagem a metade da capacidade nominal  Lavage et Séchage	
(a) capacidade nominal em kg:	2,5 kg
(b) duração do programa, expressa em horas e minutos:	8:00
(c) consumo de energia, expresso em kWh/ciclo:	1,900 kWh/ciclo
(d) consumo de água, expresso em litros/ciclo:	63 L/ciclo
(e) temperatura máxima atingida durante um mínimo de 5 minutos no interior da roupa a tratar durante o ciclo de lavagem, expressa em graus centígrados:	26°C
(f) teor de humidade remanescente após o ciclo de lavagem, expresso em percentagem do teor de água, e a velocidade de rotação a que foi alcançado:	2,90% 1400 rpm

NOTAS:

- O programa eco 40-60 é capaz de lavar roupa com sujidade normal que possa ser lavada a 40°C ou 60°C, junta no mesmo ciclo.
- Este programa é utilizado para avaliar a conformidade com a legislação de conceção ecológica da UE.
- Os programas mais eficientes em termos de consumo de energia são geralmente os que funcionam a temperaturas mais baixas e com maior duração.
- O ciclo de lavagem e secagem é capaz de limpar roupa de algodão com sujidade normal, declarada lavável a 40°C ou 60°C, no mesmo ciclo, e de a secar de modo a poder ser imediatamente guardada num armário, e que este programa é utilizado para avaliar a conformidade com a legislação de conceção ecológica da UE.
- Carregar a máquina de lavar roupa doméstica até à capacidade indicada pelo fabricante para os respetivos programas contribuirá para poupar energia e água.
- O ruído e o teor de humidade remanescente são influenciados pela velocidade de centrifugação: quanto maior for a velocidade de centrifugação na fase de centrifugação, maior será o ruído e menor será o teor de humidade remanescente.
- Os valores apresentados para os outros programas para além do programa eco 40-60 são meramente indicativos.

Especificações:	220-240V~, 50Hz 1750W (potência nominal) 1350W (potência de secagem)
Pressão da água	0,1 - 1 MPa
Grau de impermeabilidade	IPX4

REPARAÇÃO E PEÇAS SOBRESSELENTES



Não tente desmontar ou reparar o aparelho sozinho. Caso contrário, isso poderá provocar choques elétricos ou ferimentos.

Para ter acesso a uma reparação profissional e para encomendar peças sobresselentes, contacte o serviço pós-venda da FNAC DARTY. As peças sobresselentes para o seu aparelho serão entregues no prazo de 15 dias úteis após receção da encomenda.
Disponibilidade de peças sobresselentes: um período mínimo de dez anos

Atenção!

Todos os aparelhos têm uma garantia de 2 anos. A garantia não cobre danos provocados por uma instalação incorreta, modificação não autorizada, autorreparação ou reparação não profissional.

Contacte-nos em:

MediaMarkt

www.mediamarkt.pt



210 042 210

10:00 - 22:00

(inclusive feriados)

De segunda-feira a sábado

10:00 - 20:00

Domingos

E-mail: clientes@mediamarkt.pt



Rua Casal do Canas, n.º 5
Zona Comercial de Alfragide
2790-204 Carnaxide, Portugal

ELIMINAÇÃO



Como um retalhista responsável, nós cuidamos do meio ambiente. Como tal, pedimos-lhe que siga o procedimento correto para a eliminação do produto e materiais de empacotamento. Isto irá ajudar a preservar os recursos naturais e assegurar que os materiais sejam reciclados de forma a proteger a saúde e o meio ambiente.

Tem de eliminar este aparelho e material de empacotamento de acordo com as leis e normas locais. Como este aparelho contém componentes eletrónicos, o aparelho e respetivos acessórios têm de ser eliminados em separado do lixo doméstico comum quando o aparelho chegar ao fim do seu tempo de vida.

Contacte as autoridades locais para saber mais acerca da eliminação e reciclagem. O aparelho deverá ser entregue no seu ponto de recolha local para se proceder à reciclagem. Alguns pontos de recolha aceitam o aparelho livre de encargos.

Pedimos desculpa por qualquer inconveniente causado por inconsistências menores nestas instruções, as quais podem ocorrer como resultado da melhoria e desenvolvimento do produto.

Etablissements Darty & fils ©,
9 Rue des Bateaux-Lavois, 94200 Ivry-sur-Seine, France 28/02/2025

IT

INDICE

AVVERTENZE DI SICUREZZA IMPORTANTI.....	1
PANORAMICA DEL PRODOTTO.....	4
INSTALLAZIONE.....	7
PRIMA DI OGNI LAVAGGIO.....	10
LAVAGGIO E ASCIUGATURA.....	12
TABELLA DEI PROGRAMMI.....	17
FUNZIONI AGGIUNTIVE.....	19
PULIZIA E MANUTENZIONE.....	21
RISOLUZIONE DEI PROBLEMI.....	24
Scheda informativa del prodotto.....	27
SERVIZIO ASSISTENZA PER RIPARAZIONI E RICAMBI.....	32
SMALTIMENTO.....	33

Questo prodotto è stato fabbricato e venduto sotto la responsabilità di Etablissements Darty et Fils (SAS). THOMSON e il logo THOMSON sono marchi utilizzati su licenza di Etablissements Darty et Fils (SAS). Per ulteriori informazioni visitare il sito: www.thomson-brand.com .

Tutti gli altri prodotti, servizi, aziende, marchi, nomi commerciali o di prodotto e loghi qui menzionati appartengono ai rispettivi proprietari.

AVVERTENZE DI SICUREZZA IMPORTANTI

LEGGERE ATTENTAMENTE LE SEGUENTI AVVERTENZE DI SICUREZZA E LE ISTRUZIONI PRIMA DI UTILIZZARE L'APPARECCHIO E CONSERVARLE PER RIFERIMENTO FUTURO.

Avvertenze



- Leggere le istruzioni.
- Questo apparecchio è destinato all'uso in ambienti domestici o similari, come ad esempio:
 - in aree per il personale in negozi, uffici e altri ambienti di lavoro;
 - in agriturismi;
 - in aree ad uso dei clienti di hotel, motel e altri ambienti residenziali;
 - ambienti tipo bed and breakfast;
 - aree ad uso comune in condomini.
- Per motivi di sicurezza, se il cavo di alimentazione è danneggiato deve essere sostituito dal costruttore, dal suo centro di assistenza o da un tecnico qualificato.
- Questo apparecchio può essere usato da bambini di età superiore a 8 anni e da persone con ridotte capacità fisiche, sensoriali o mentali o prive di esperienza e conoscenza, solo se supervisionati o istruiti sull'uso sicuro dell'apparecchio e se comprendono i rischi correlati.

I bambini non devono giocare con l'apparecchio.

Le operazioni di pulizia e manutenzione ordinaria non devono essere effettuate da bambini senza supervisione.
- **ATTENZIONE!** Non allacciarlo alla rete di acqua potabile.
- Le aperture non devono essere ostruite da tappeti.
- La pressione dell'acqua non deve essere inferiore a 0,1 MPa e non superiore a 1 MPa.
- Devono essere utilizzati i nuovi set di tubi flessibili forniti con l'apparecchio e non quelli vecchi.
- I bambini di età inferiore ai 3 anni devono essere tenuti lontani, a meno che non siano costantemente sorvegliati.
- Per istruzioni dettagliate sul metodo di pulizia, vedere la sezione "PULIZIA E

MANUTENZIONE” a pagina 21-23.

- La massa massima di materiale tessile asciutto in chilogrammi da inserire nell'apparecchio è di 8 kg (per il ciclo di lavaggio) e di 5 kg (per il ciclo di lavaggio e asciugatura).
- L'asciugatrice non deve essere utilizzata se per la pulizia sono stati impiegati prodotti chimici industriali.
- Il filtro antipelucchi deve essere pulito frequentemente.
- Non far accumulare lanugine intorno all'asciugatrice.
- È necessario garantire un'adeguata ventilazione per evitare che nella stanza si abbia il reflusso di gas provenienti da apparecchi che bruciano altri combustibili, comprese fiamme libere.
- Non asciugare nell'asciugatrice capi non lavati.
- Indumenti sporchi di sostanze quali olio da cucina, acetone, alcol, benzina, cherosene, smacchiatori, trementina, cere e prodotti per rimuovere la cera devono essere lavati in acqua calda con una quantità extra di detersivo prima di essere asciugati nell'asciugatrice.
- Non vanno asciugati in asciugatrice articoli come gommapiuma (schiuma di lattice), cuffie da doccia, tessuti impermeabili, articoli con supporto in gomma e vestiti o cuscini dotati di cuscinetti in gommapiuma.
- Gli ammorbidenti o prodotti simili devono essere utilizzati seguendo le istruzioni fornite con l'ammorbidente stesso.
- Togliere dalle tasche tutti gli oggetti come accendini e fiammiferi.
- **AVVERTENZA! Non fermare mai l'asciugatrice prima della fine del ciclo di asciugatura, a meno che tutti i capi non vengano rapidamente rimossi e stesi in modo da dissipare il calore.**
- **AVVERTENZA! L'apparecchio non deve essere alimentato tramite un dispositivo di commutazione esterno, come per esempio un timer, né collegato a un circuito che viene regolarmente acceso e spento da una società di servizi.**
- L'aria di scarico non deve essere immessa in una canna fumaria utilizzata per l'evacuazione dei fumi di apparecchi che bruciano gas o altri combustibili.
- L'apparecchio non deve essere installato dietro una porta bloccabile, una porta scorrevole o una porta con cerniere sul lato opposto a quello dell'asciugatrice, che possa impedire l'apertura completa del suo sportello.

Precauzioni di sicurezza

- L'apparecchio è destinato esclusivamente all'uso in ambienti interni.
- Per evitare pericoli, tenere i materiali di imballaggio dell'apparecchio fuori dalla portata dei bambini.
- Non collegare l'apparecchio alla presa di corrente con le mani bagnate.
- Non toccare mai l'apparecchio con mani o piedi bagnati.
- In caso di guasto, staccare innanzitutto la spina e chiudere il rubinetto dell'acqua. Non tentare di riparare l'apparecchio da soli. Contattare il proprio agente di assistenza autorizzato.
- Non superare la capacità di carico massima.
- Durante il ciclo di lavaggio, lo sportello in vetro diventa molto caldo. Tenere bambini e animali domestici lontani dall'apparecchio mentre è in funzione.
- Non forzare mai l'apertura dello sportello quando l'apparecchio è in funzione.
- Non lasciare bambini incustoditi vicino all'apparecchio perché potrebbero chiudersi al suo interno.
- Dopo l'uso, staccare sempre la spina e chiudere l'alimentazione idrica.
- Animali e bambini possono arrampicarsi sull'apparecchio. Controllare l'apparecchio prima di ogni operazione.
- Dopo l'installazione dell'apparecchio, la spina deve rimanere facilmente accessibile.
- Non lavare articoli che sono stati puliti, lavati, immersi o tamponati con sostanze combustibili o esplosive (come cera, olio, vernice, benzina, sgrassatori, solventi per lavaggio a secco, cherosene, ecc.). Ciò potrebbe causare incendi o esplosioni.
- L'apparecchio non deve essere installato in bagni o in locali molto umidi, né in locali in cui siano presenti gas esplosivi o caustici.

PANORAMICA DEL PRODOTTO



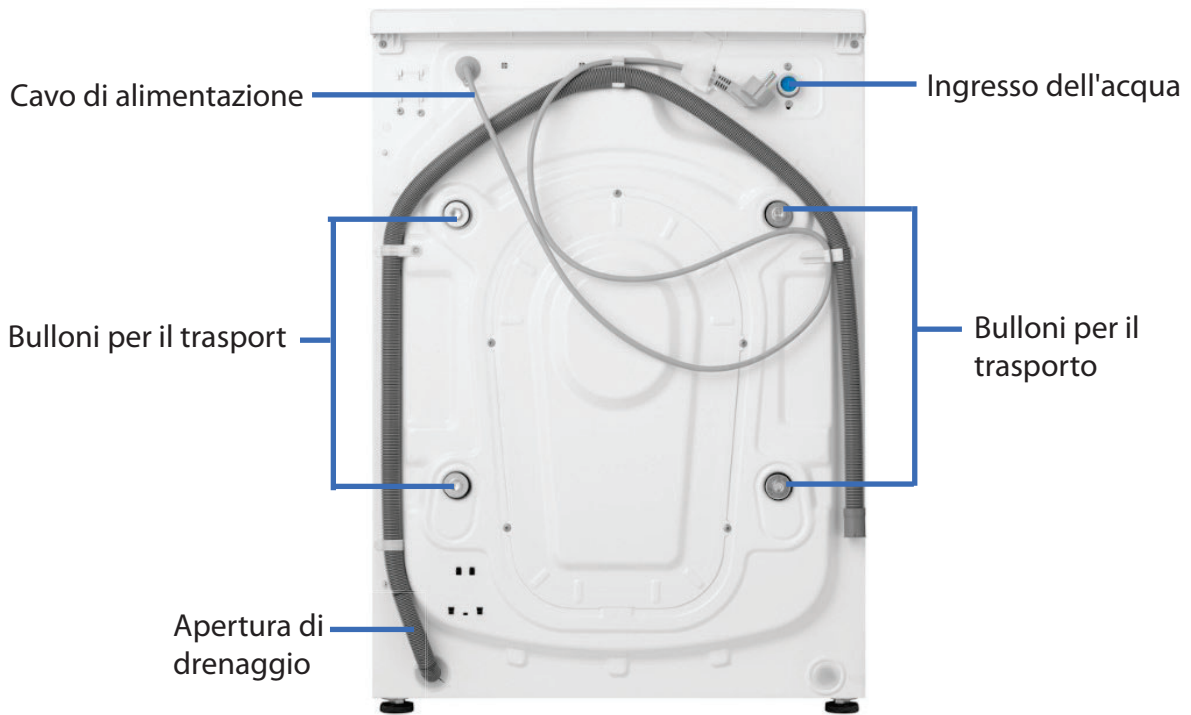

Accessori



Pannello di controllo

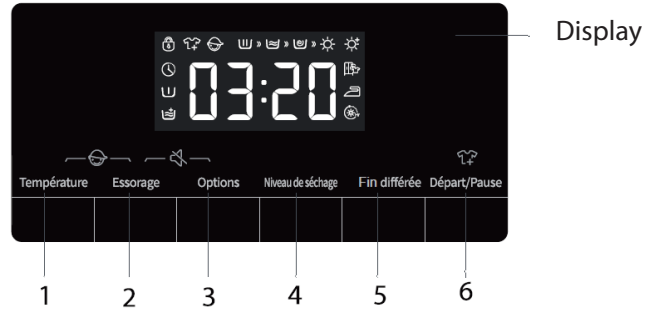
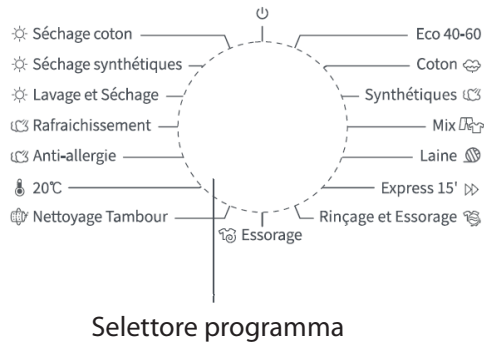

- 1 Pulsante della temperatura
- 2 Pulsante di rotazione
- 3 Pulsante opzioni
- 4 Pulsante livello asciugatura
- 5 Pulsante di fine ritardo
- 6 Pulsante di avvio/pausa

- 1 + 2 Funzione di blocco bambini
- 2 + 3 Funzione suono
- 6 Funzione ricarica

Indicatori sul display

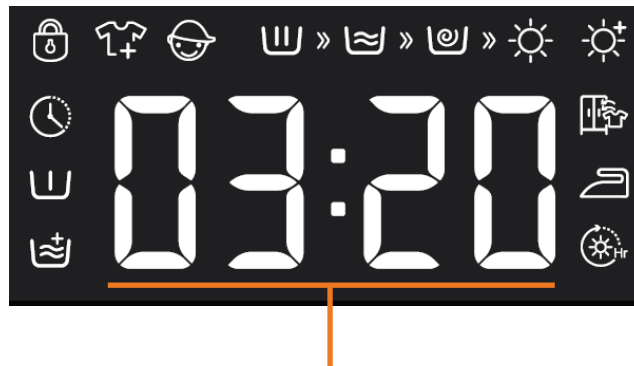

Visualizzazione del tempo di lavaggio, velocità, codice di errore, temperatura

Sportello bloccato	Ricaricare	Blocco bambini	Fine ritardo	Prelavaggio	Risciacquo extra

Simboli di livello asciugatura

Asciugatura extra	Asciugatura pronto armadio	Asciugatura pronto stiro	Asciugatura temporizzata

I simboli vengono visualizzati sul display quando è impostata la fase corrispondente.

	»		»		»	
Fase di lavaggio		Fase di risciacquo		Fase di centrifuga		Fase di asciugatura

INSTALLAZIONE

■ Rimozione dell'imballaggio

1. Rimuovere la scatola di cartone e l'imballaggio di polistirolo.
2. Sollevare la lavatrice e rimuovere l'imballaggio della base. Saranno necessarie 2 o più persone.
3. Rimuovere il nastro che fissa il cavo di alimentazione e il tubo di scarico.



AVVERTENZA :

I materiali di imballaggio (ad esempio pellicole, polistirolo) possono essere pericolosi per i bambini.

Sussiste il rischio di soffocamento ! **Tenere tutti gli imballaggi fuori dalla portata dei bambini.**

■ Rimozione dei bulloni per il trasporto

L'apparecchio è dotato di bulloni per il trasporto per evitare danni interni durante il trasporto. Prima di utilizzare l'apparecchio, rimuovere l'imballaggio e tutti i bulloni utilizzati per il trasporto.

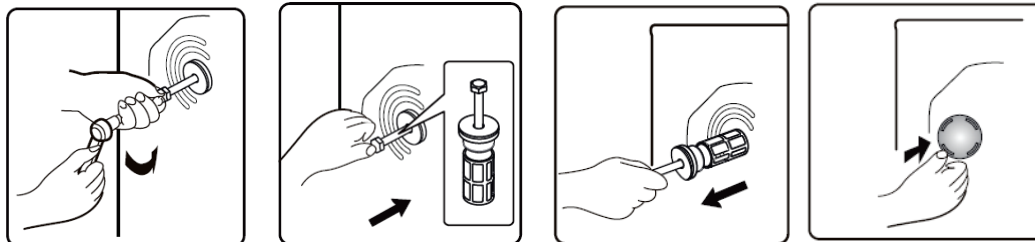

1. Utilizzare una chiave inglese per ruotare le teste dei bulloni in senso antiorario finché non è possibile estrarli parzialmente.
2. Spingere i bulloni per il trasporto verso l'interno per allentarli.
3. Rimuovere i bulloni per il trasporto e le bocche in gomma tirandoli verso l'esterno.
4. Chiudere i fori con i tappi in dotazione.

■ Posizionamento

Installare l'apparecchio su un pavimento robusto e in piano.
Assicurarsi che la circolazione dell'aria attorno all'apparecchio non sia ostacolata da tappeti, moquette, eccetera.
Lasciare almeno 2 cm di spazio libero su ciascun lato dell'apparecchio.
Assicurarsi che l'apparecchio non poggi sul cavo di alimentazione.

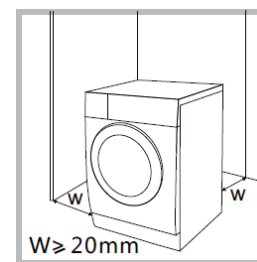

■ Requisiti del luogo di installazione

Prima di installare l'apparecchio, si dovrà scegliere il luogo che dovrà avere le seguenti caratteristiche:

- superficie rigida, asciutta e in piano
- non esposto alla luce solare diretta
- ventilazione sufficiente
- La temperatura ambiente è superiore a 0°C.
- Tenere lontano da fonti di calore come apparecchi a carbone o a gas.

■ Livellamento dell'apparecchio

Se si livella correttamente la lavatrice, si evitano rumori e vibrazioni eccessivi.
Installare l'apparecchio su una superficie solida e piana.

Se il pavimento non è uniforme, ruotare i piedini regolabili come necessario.

- Non mettere mai cartoni, blocchi di legno o materiali simili sotto i piedini.

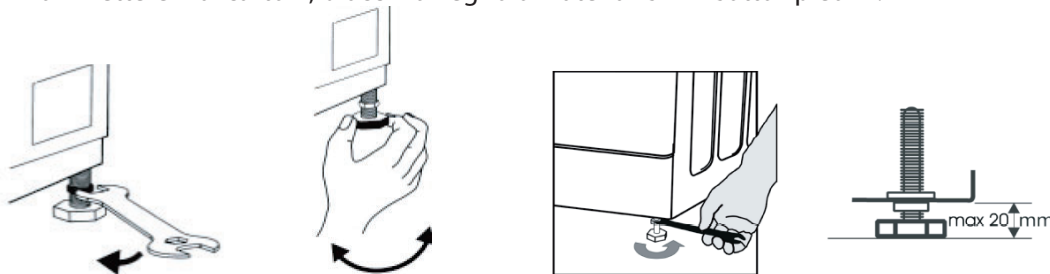

1. Allentare i controdadi con una chiave inglese.
2. Per regolare l'altezza, ruotare i piedini regolabili.
 - Assicurarsi che tutti e quattro i piedini siano stabili e appoggiati al pavimento, quindi controllare che l'apparecchio sia perfettamente in piano utilizzando una livella a bolla.
3. Stringere i controdadi.

■ Installazione del coperchio inferiore

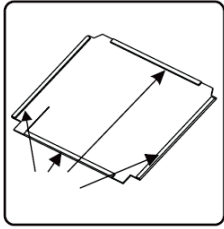

1. Staccare la carta protettiva dai nastri biadesivi sui quattro lati della piastra inferiore.

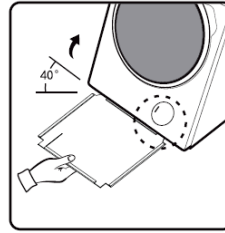

2. Inclinare l'apparecchio all'indietro (angolo di inclinazione : 40°) e inserire la piastra inferiore.

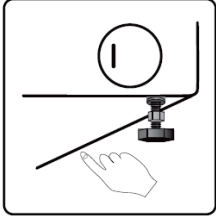

3. Premere i nastri biadesivi per fissare la piastra inferiore all'apparecchio.

Attenzione: Per ridurre la rumorosità, assicurarsi di installare la "Piastra inferiore antirumore" in dotazione. Si prega di leggere e seguire la guida all'installazione sulla targhetta inerente la riduzione del rumore e nel manuale di istruzioni.

■ Collegamenti elettrici

La lavatrice funziona a 220-240 V e 50 Hz.

I collegamenti elettrici devono essere eseguiti da un tecnico qualificato nel rispetto delle normative di sicurezza locali.

La lavatrice deve essere correttamente collegata a terra. Non saremo ritenuti responsabili per eventuali danni che potrebbero verificarsi a seguito di un utilizzo senza un corretto collegamento a terra.

Non utilizzare prolunghe o prese multiple.

L'apparecchio non deve avere un dispositivo di commutazione esterno, come un timer, né essere collegato a un circuito che venga acceso e spento regolarmente.

Non staccare la spina dalla presa di corrente se nelle vicinanze sono presenti gas infiammabili.

■ Collegamento dei tubi flessibili

Collegamento del tubo di alimentazione dell'acqua



L'apparecchio deve essere collegato ad un condotto d'acqua fredda.

Assicurarsi che il tubo non sia torto o schiacciato.

1. Avvitare un'estremità del tubo di alimentazione sul retro dell'apparecchio.

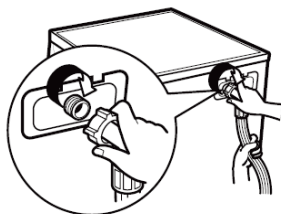

2. Collegare l'altra estremità del tubo di ingresso a un rubinetto filettato da 3/4".

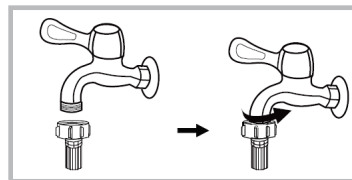

**NOTA :**

Dopo aver completato il collegamento, aprire lentamente il rubinetto e accertarsi che non vi siano perdite.

Non torcere, schiacciare, modificare o tagliare il tubo.

Allacciamento del tubo di scarico

Per installare il tubo di scarico, utilizzare uno dei seguenti metodi.

Assicurarsi che il tubo di scarico non si pieghi, non si deformi, non sia schiacciato né allungato.

- Spingere con fermezza il tubo in un condotto di scarico.

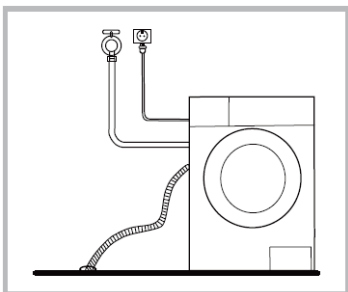

- Quando si installa il tubo di scarico al lavandino, fissarlo saldamente con una corda.

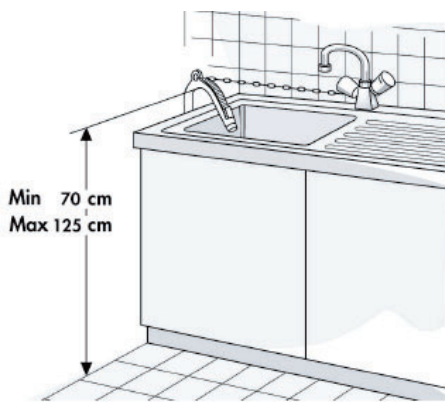
**NOTA:**

Il tubo di scarico dell'acqua deve essere montato a un'altezza minima di 70 cm e massima di 125 cm dal suolo.

PRIMA DI OGNI LAVAGGIO**Regole per la separazione della biancheria**

- Tipo di tessuto/simbolo sull'etichetta di lavaggio (cotone, fibre miste, sintetico, lana, capi da lavare a mano)
- Colore
Separare i capi colorati da quelli bianchi. Lavare separatamente i capi colorati nuovi.
- Dimensioni
Lavare capi di dimensioni diverse nello stesso carico per migliorare l'efficacia del lavaggio e la distribuzione dei capi nel cestello.
- Delicati
Lavare separatamente i capi delicati.
- Gli articoli per neonati (vestitini, asciugamani e tovaglioli) devono essere lavati separatamente. Se vengono lavati insieme ai vestiti degli adulti, potrebbero infettarsi. I tempi di risciacquo devono essere aumentati per garantire un risciacquo e una pulizia accurati, senza nessun residuo di detergente.
- Si consiglia di lavare a mano i capi che si macchiano facilmente, come calzini bianchi, colletti, maniche eccetera, prima di metterli in lavatrice, per ottenere risultati di lavaggio migliori.

Tasche vuote



Controllare tutte le tasche per assicurarsi che siano vuote. Oggetti come chiodi, fermagli per capelli, fiammiferi, penne, monete e chiavi possono danneggiare sia l'elettrodomestico che i vestiti.

Chiudere tutte le cerniere, i bottoni e i ganci.

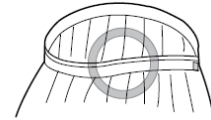
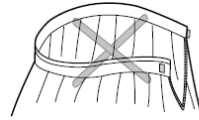

Chiudere cerniere, ganci e lacci per evitare che si impiglino nei vestiti.
Annodare tutti i nastri o le cinture.

Detersivo

Leggere le istruzioni sulla confezione del detersivo o di altri agenti pulenti per conoscerne la dose corretta in base alla quantità di bucato, al grado di sporco e alla durezza dell'acqua.

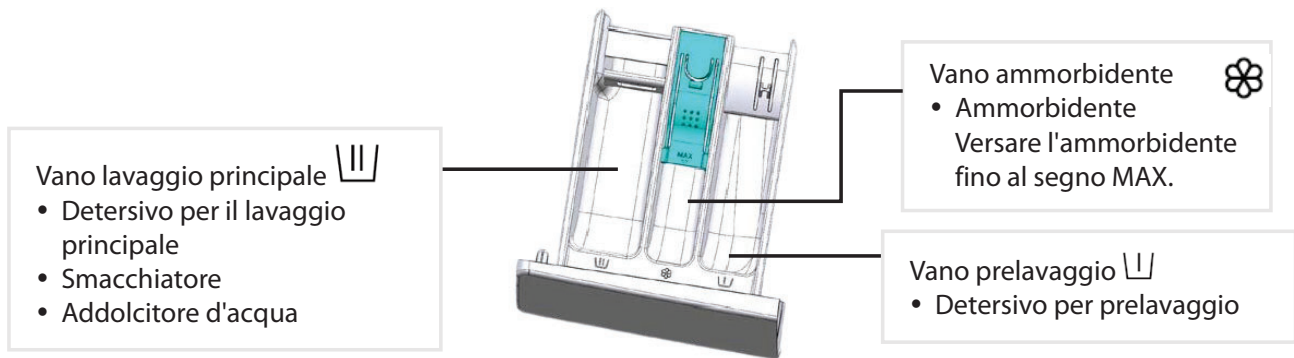

La scelta del detersivo dipende da:

- tipo di tessuto (cotone, tessuti facili da lavare/sintetici, capi delicati, lana).
- Nota:** Per il lavaggio della lana utilizzare solo detersivi specifici.
- Colore
 - Temperatura di lavaggio
 - grado e tipo di sporco

Note

- Eventuali residui biancastri sui tessuti scuri sono causati da composti insolubili utilizzati nei moderni detersivi in polvere senza fosfati. In tal caso, scuotere o spazzolare il tessuto oppure utilizzare detersivi liquidi.
- Utilizzare solo detersivi e ammorbidenti specifici per lavatrici ad uso domestico.
- Se si utilizzano decalcificanti, coloranti o candeggina per il prelavaggio, assicurarsi che siano adatti all'uso in lavatrici per uso domestico. Il decalcificante potrebbe contenere prodotti che potrebbero danneggiare la lavatrice.
- Non utilizzare solventi (ad esempio trementina, benzene). Non lavare in lavatrice tessuti trattati con solventi o liquidi infiammabili.
- Conservare i detersivi e gli additivi in un luogo sicuro e asciutto, fuori dalla portata dei bambini.
- Per evitare problemi di erogazione quando si utilizzano detersivi in polvere e liquidi altamente concentrati, utilizzare la speciale pallina o sacchetto per detersivo forniti con il detersivo e posizionarlo direttamente all'interno del cestello.

LAVAGGIO E ASCIUGATURA

Prima del primo ciclo di lavaggio

Per eliminare eventuali residui di acqua rimasti durante i test effettuati dal produttore, si consiglia di effettuare un breve ciclo di lavaggio senza biancheria.

1. Aprire il rubinetto.
2. Chiudere lo sportello.
3. Versare una piccola quantità di detersivo nell'apposito scomparto per detersivo liquido/in polvere
Dosaggio Manuale per la fase di lavaggio.
4. Selezionare e avviare un programma breve.

Lavare e asciugare il bucato

1. Aprire lo sportello per caricare i capi nel cestello.



NON SOVRACCARICARE l'apparecchio.
Rispettare le quantità di carico indicate nella tabella dei programmi.
Sovraccaricare l'apparecchio causerà risultati di lavaggio scadenti.

2. Chiudere lo sportello.

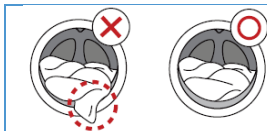

Assicurarsi che nessun capo rimanga incastrato tra lo sportello e la guarnizione.

3. Aggiungere detersivo e ammorbidente.

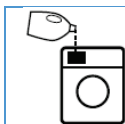

Estrarre il cassetto.
Aggiungere detersivo e ammorbidente negli scomparti corrispondenti.
Non riempirli eccessivamente.

4. Aprire l'erogazione idrica.

5. Selezionare il programma desiderato.

Ruotare la manopola dei programmi per selezionare il programma desiderato.
Il display mostrerà il tempo di lavaggio.



Il selettore programmi serve anche per accendere o spegnere la macchina.

Per una panoramica dettagliata dei programmi, vedere la Tabella dei programmi.

6. Se necessario, modificare la temperatura.





Premere ripetutamente **Température** fino a raggiungere la temperatura desiderata.

7. Se necessario, modificare la velocità di centrifuga.

Premere ripetutamente **Essorage** per impostare la velocità di centrifuga desiderata.

8. Selezionare le opzioni, se necessario.

Premere ripetutamente **Options** per selezionare l'opzione desiderata. Le opzioni sono disponibili solo quando vengono selezionati alcuni programmi. Quando si seleziona l'opzione, sul display verrà visualizzato il simbolo corrispondente.

<p> Prelavaggio</p> <p>Selezionare questa opzione per lavare i capi molto sporchi. Prima del lavaggio, il detersivo per bucato/detersivo in polvere può essere aggiunto nello scomparto del prelavaggio, mentre il detersivo in polvere deve essere aggiunto nello scomparto del lavaggio principale.</p>	 <p>Disponibile per questi programmi</p> <ul style="list-style-type: none">Anti-allergie20°CCotonSynthétiquesMix
<p> Risciacquo extra</p> <p>Selezionare questa opzione per aggiungere un ciclo di risciacquo aggiuntivo per ottenere risultati di risciacquo migliori.</p>	 <p>Disponibile per questi programmi</p> <ul style="list-style-type: none">Anti-allergie20°CCotonSynthétiquesMixLaineExpress 15'Rinçage et Essorage

9. Selezionare il livello di asciugatura desiderato.

Premere ripetutamente **Niveau de séchage** per selezionare il livello di asciugatura desiderato e il display visualizza il simbolo del livello impostato:

	<p>Asciugatura extra: bucato completamente asciutto</p>	Séchage coton	Eco 40-60
		Séchage synthétiques	Coton
			Synthétiques
			Mix
		Anti-allergie	
		20°C	
		Essorage	
			Rinçage et Essorage

Disponibile per questi programmi

L'apparecchio è in grado di rilevare il peso dei vestiti per regolare automaticamente il tempo di asciugatura.

Prima di procedere all'asciugatura, verificare che i vestiti possano essere asciugati.

Non lavabile • vestiti asciutti/non asciutti

Vestiti che non possono essere né lavati né asciugati



Prodotti in pelle e pellicce
(Potrebbero deformarsi.)



Rayon e i prodotti che in parte lo
contengono
(Potrebbero verificarsi scolorimenti
o deformazioni.)

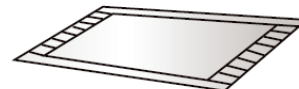

Grandi cuscini di gomma
spessa con carbammato
sul retro
(Potrebbero verificarsi
danni o guasti.)



Cappelli con materiale duro
(Altrimenti si danneggerà la
macchina e causeranno
guasti.)



Cuscini, guanciali, articoli con ovatta
di cotone, schiuma e altri materiali
spugnosi, rivestimenti per tappeti
(potrebbero verificarsi danni o
guasti.)

Altro
Vestiti stropicciati o
goffrati; tessuti in crepe;
Abiti facilmente
deformabili (completi,
giacche, cravatte, vestiti,
ecc.);
Vestiti che si gonfiano
facilmente (velluto,
vellutino).

Vestiti che non possono essere asciugati nella macchina

 <p>Qualsiasi indumento contrassegnato da grafica (Gli abiti potrebbero danneggiarsi.)</p>	 <p>Vestiti di lana (Potrebbero verificarsi restringimento e perdita di pelo.)</p>	 <p>Collant, calze (Potrebbero verificarsi danni o deformazioni.)</p>	 <p>Vestiti che possono restringersi</p>
 <p>Cuscini o vestiti con pellicce (Potrebbero verificarsi danni o guasti.)</p>	 <p>Trapunta (Potrebbero verificarsi danni o guasti.)</p>	 <p>Abiti con pizzo e ricami, nuova fibra sintetica (fibra molto fine) (Potrebbero verificarsi delle deformazioni.)</p>	 <p>Seta</p>

Nota

Gli indumenti asciutti/non asciutti non lavabili includono, ma non sono limitati a, gli indumenti sopra menzionati.

I vestiti bagnati che gocciolano non sono adatti all'asciugatura, il che può causare l'attivazione dell'allarme della macchina!

Durata asciugatura

Quando il display mostra il

simbolo , premere ripetutamente **Niveau de séchage** per impostare il tempo più adatto ai tessuti che si desidera asciugare. Il display visualizzerà il tempo impostato (30 minuti, 1 ora, 1,5 ore, 2 ore, 3 ore e 4 ore).



- Prima di procedere all'asciugatura separata, togliere gli indumenti semi-pronti dal cestello e rimmetterli in seguito con un programma più delicato.
- Se si asciugano pochi indumenti o indumenti leggeri, il tempo di asciugatura potrebbe essere più breve del tempo impostato.

- Se è necessario asciugare i vestiti lavati a mano, prima di asciugarli selezionare la velocità della centrifuga in base al tipo di indumento. Si consiglia di selezionare i programmi "Centrifuga + Livello Asciugatura".
- Al termine del programma di asciugatura, la macchina funzionerà per un certo periodo di tempo, ad un ritmo specifico, per ammorbidire i vestiti e ridurre le pieghe.
- Un'asciugatura eccessiva può compromettere il risultato di asciugatura, mentre un'asciugatura eccessiva può causare la formazione di pieghe sui vestiti. Per i vestiti in fibra chimica, come ad esempio le camicie, ecc., selezionare l'asciugatura pronto stiro .
- Se si asciugano insieme indumenti composti da tessuti diversi, le prestazioni di asciugatura potrebbero risultare compromesse. Si consiglia quindi di separare correttamente i vestiti prima di asciugarli.

10. Avvio di un programma.

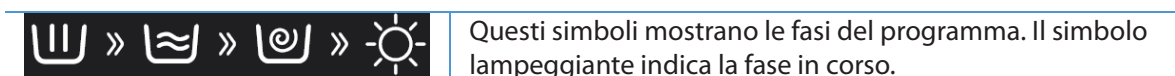

Premere **Départ/Pause**. Lo sportello si bloccherà e sul display verrà visualizzato il simbolo .



Pesatura automatica

Dopo l'avvio di un programma, sul display verrà visualizzato "----", a indicare che la pesatura avviene automaticamente. Regolerà automaticamente la durata del programma (ore:minuti) in base al peso del bucato.

11. Mettere in pausa un programma in corso e aprire lo sportello, se necessario.

- Premere **Départ/Pause** per mettere in pausa un programma in corso.
- Se il livello o la temperatura dell'acqua non sono troppo alti, il simbolo della porta bloccata  scomparirà e sul display verrà visualizzato il simbolo di ricarica . È possibile aprire lo sportello, ad esempio, per aggiungere altro bucato o per estrarre il bucato caricato per errore.
- Premere **Départ/Pause** per procedere con il programma.

12. Se necessario, modificare un programma e le impostazioni.

Per modificare le impostazioni di un programma in corso:



- Ruotare il selettore programmi in posizione Off  per 3 secondi.
- Selezionare un nuovo programma e modificare le impostazioni.
- Premere **Départ/Pause** per avviare il nuovo programma.

13. Al termine del ciclo sul display verrà visualizzato il messaggio "End" (Fine).

14. Spegnerla macchina ruotando il selettore programmi in posizione Off .

15. Aprire lo sportello ed estrarre la biancheria.















- Lo sportello può essere aperto solo quando il simbolo  scompare.
- Controllare che il simbolo  scompare.
- Aprire lo sportello e tirare fuori la biancheria.
- Lasciare lo sportello socchiuso per far asciugare l'interno dell'elettrodomestico.



















Chiudere il rubinetto.

TABELLA DEI PROGRAMMI

Programma	Funzioni	Carico massimo (kg)	Temperature	Velocità di rotazione massima (giri/min)
 Séchage coton Asciugatura cotone	Asciugatura	5	—	—
 Séchage synthétiques Asciugatura sintetici	Asciugatura	5	—	—
 Lavage et Séchage Lavare e asciugare	Lavare e asciugare	5	—	1400
 Rafrachissement Ravviva con il vapore	Asciugatura	2	—	—
 Anti-allergie Trattamento anallergico	Lavaggio	4	40°C, 60°C, 90°C	1400
	Lavare e asciugare	4		
20°C	Lavaggio	8	20°C	1400
	Lavare e asciugare	5		
 Nettoyage Tambour Pulire iltamburo	Lavare e asciugare	—	90°C	800
ECO 40-60	Lavaggio	8	—	1400
	Lavare e asciugare	5		
 Coton Cotone	Lavaggio	8	Freddo, 20°C, 30°C, 40°C, 60°C, 90°C	1400
	Lavare e asciugare	5		
 Synthétiques Sintetici	Lavaggio	8	Freddo, 20°C, 30°C, 40°C, 60°C	1200
	Lavare e asciugare	5		1400
 Mix Mix	Lavaggio	4	Freddo, 20°C, 30°C, 40°C	1400
	Lavare e asciugare			
 Laine Lana	Lavaggio	2	Freddo, 20°C, 30°C, 40°C	600
 Express 15' Veloce 15'	Lavaggio	1	Freddo, 20°C, 30°C, 40°C	800

Rinçage et Essorage 	Lavaggio	8	—	1400
	Risciacquo + Centrifuga	Lavare e asciugare		
 Essorage	Centrifuga	8	—	1400
	Centrifuga	Centrifugare e asciugare		

Programma	Descrizione programma (Tipo di carico e livello di sporco)	Detergenti e additivi		
		Prelavaggio 	Lavaggio principale 	Ammorbidente 
 Séchage coton Asciugatura cotone	I vestiti bagnati in cotone e lino possono essere asciugati dopo essere stati centrifugati.	—	—	—
 Séchage synthétiques Asciugatura sintetici	I vestiti in fibra chimica bagnati possono essere asciugati dopo essere stati centrifugati.	—	—	—
 Lavage et Séchage Lavare e asciugare	Il ciclo di lavaggio e asciugatura è in grado di lavare insieme, nello stesso ciclo, biancheria di cotone normalmente sporca lavabile a 40 °C o 60 °C e di asciugarla in modo tale da poterla riporre immediatamente in un armadio; tale programma viene utilizzato per valutare la conformità alla normativa UE in quanto a ecocompatibilità.	○	●	○
 Anti-allergie Ravvivare con il vapore	È adatto per rimuovere dai vestiti odori particolari (ad esempio odore di fumo/pentola calda/barbecue, ecc.).	—	—	—
 Anti-allergie Trattamento anallergico	Programma per eliminare efficacemente i batteri dai tessuti. È adatto per i vestiti di bambini.	○	●	○
20°C	Un ciclo di lavaggio in grado di lavare capi di cotone leggermente sporchi, ad una temperatura nominale di 20 °C	○	●	○
 Nettoyage Tambour Pulire il tamburo	Programma per rimuovere lo sporco e i residui batterici che possono proliferare nella macchina dopo un certo periodo di utilizzo, soprattutto quando si effettuano regolarmente lavaggi a basse temperature.	—	—	—
ECO 40-60	Un ciclo di lavaggio in grado di lavare capi di cotone normalmente sporchi lavabili a 40 °C o 60 °C.	○	●	○
 Coton Cotone	Per lavare cotone o lino molto e normalmente sporchi Per capi molto sporchi selezionare la funzione "Prelavaggio"	○	●	○

Synthétiques  Sintetici	Per tessuti sintetici moderatamente sporchi, tessuti misto cotone	<input type="radio"/>	<input checked="" type="radio"/>	<input type="radio"/>
Mix  Mix	Per carichi misti di tessuti sintetici e di cotone mediamente sporchi	<input type="radio"/>	<input checked="" type="radio"/>	<input type="radio"/>
Laine  Lana	Per lana lavabile in lavatrice. (Fare riferimento all'etichetta di lavaggio applicata sul capo).	<input type="radio"/>	<input checked="" type="radio"/>	<input type="radio"/>
Express 15'  Veloce 15'	Per lavare velocemente capi leggermente sporchi	<input type="radio"/>	<input checked="" type="radio"/>	<input type="radio"/>
Rinçage et Essorage  Risciacquo + Centrifuga	Questo programma è impostato di default su due risciacqui e una centrifuga.	—	—	<input type="radio"/>
 Essorage Centrifuga	Centrifuga extra con velocità di centrifuga selezionabile	—	—	—

● = dosaggio richiesto / ○ = facoltativo

FUNZIONI AGGIUNTIVE

■ Funzione di fine ritardo

È possibile utilizzare questa funzione per impostare la fine del programma in un secondo momento. L'orario di fine ritardo può essere scelto tra 1 e 24 ore, con incrementi di 1 ora.

1. Selezionare un programma.
2. Premere ripetutamente **Fin différée** per selezionare l'orario di fine desiderato.
 - Le ore visualizzate indicano l'ora in cui terminerà il programma.
 - Il display mostrerà il simbolo .
3. Premere **Départ/Pause** per avviare il programma.
 - La macchina inizierà quindi il conto alla rovescia.

Ad esempio, se la durata del programma è superiore a 2 ore, la funzione di fine ritardo minimo deve partire da 3 ore.

Se la durata del programma selezionato è di 2:28 ore e si imposta il tempo di "Fine ritardo" su 6 ore, il programma di lavaggio terminerà dopo 6 ore.

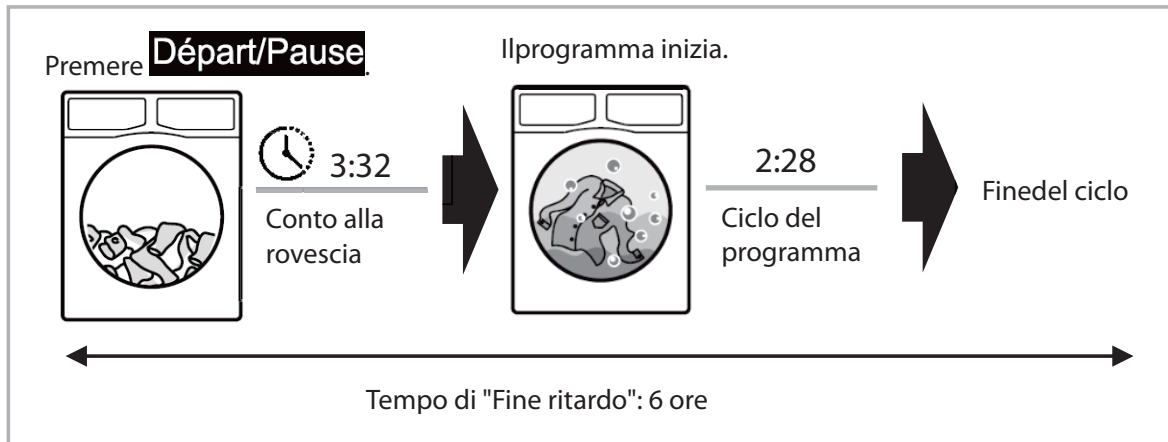

Se si desidera annullare questa funzione prima di avviare il programma, premere ripetutamente

Fin différée finché il simbolo  non viene più visualizzato.

Per annullare questa funzione dopo aver avviato il programma, spegnere la macchina ruotando la manopola del programma in posizione Off .

■ Funzione segnalazione acustica

Con questa funzione è possibile attivare o disattivare la segnalazione acustica emessa quando si premono i pulsanti o si ruota il selettore programmi.

- Premere e tenere premuto **Essorage** e **Options** contemporaneamente per circa 2 secondi finché il display non visualizza "bEEp oFF", per indicare che il suono è disattivato.
- Per disattivare questa funzione, tenere premuto **Essorage** e **Options** contemporaneamente per circa 2 secondi. Il display visualizza la scritta "bEEp oN".

■ Funzione di blocco bambini

Per aumentare la sicurezza dei bambini, questa macchina è dotata della funzione di blocco bambini.

Quando il programma si avvia, tenere premuto **Température** e **Essorage** contemporaneamente per 2 secondi. Il display mostrerà il simbolo , indicando che la funzione è attivata.

Quando la funzione è attivata, tutti i pulsanti funzione saranno bloccati.

Per disattivare questa funzione, tenere premuto **Température** e **Essorage** contemporaneamente per altri 2 secondi. Il simbolo  scomparirà dal display.

- Quando si spegne la macchina ruotando il selettore programmi in posizione Off , la funzione di

blocco bambini è disattivata.

- Al termine del programma, il blocco bambini si sbloccherà automaticamente.

PULIZIA E MANUTENZIONE



AVVERTENZA :

Prima di effettuare operazioni di pulizia e manutenzione, scollegare sempre l'apparecchio e chiudere il rubinetto dell'acqua.

■ **Pulizia dell'alloggiamento della macchina**

Pulire con un panno morbido e umido.

Non utilizzare detergenti chimici o abrasivi.

Rimuovere immediatamente i residui di detersivo e detergenti.

■ **Pulizia del tamburo**

Eventuali macchie di ruggine lasciate all'interno del cestello da oggetti metallici devono essere rimosse immediatamente utilizzando detersivi senza cloro. Non utilizzare mai lana d'acciaio per pulire il cestello!

Per rimuovere il calcare dal cestello, eseguire il ciclo di pulizia con un agente decalcificante, seguendo le istruzioni del produttore per il corretto dosaggio.

■ **Pulizia della guarnizione dello sportello e del vetro**

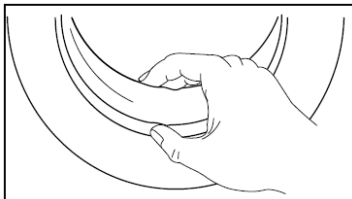

Dopo ogni lavaggio, pulire il vetro e la guarnizione per rimuovere pelucchi e macchie. L'accumulo di lanugine può causare perdite.

Dopo ogni lavaggio, rimuovere monete, bottoni e altri oggetti dalla guarnizione.

Per garantire il normale funzionamento della macchina, pulire ogni mese la guarnizione e il vetro dello sportello.

■ **Pulizia del filtro di ingresso**



NOTA :

Se l'acqua non viene erogata correttamente, pulire il filtro di ingresso.

Se l'acqua è molto dura o contiene tracce di calcare, il filtro di ingresso dell'acqua potrebbe intasarsi. Si consiglia di pulire periodicamente il filtro di ingresso.

1. Chiudere il rubinetto dell'acqua e svitare il tubo di ingresso.

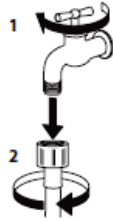

2. Pulire con cura il filtro a rete all'estremità del tubo flessibile utilizzando una spazzola fine.



3. Svitare manualmente il tubo di ingresso sul retro dell'apparecchio. Estrarre il filtro a rete dalla valvola posta sul retro dell'apparecchio con una pinza e pulirlo con cura sotto l'acqua corrente.

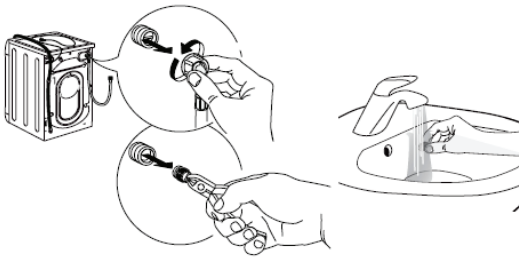

4. Reinserire il filtro a rete nell'apparecchio. Collegare il tubo di ingresso al rubinetto dell'acqua e all'apparecchio. Aprire il rubinetto dell'acqua e verificare che tutti i collegamenti siano ben serrati.

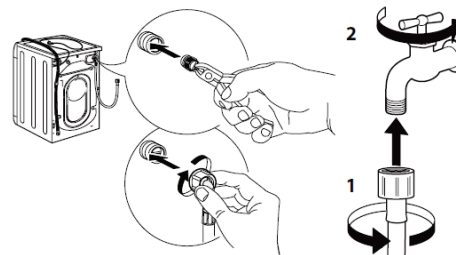

■ Pulizia del cassetto del detersivo



NOTA :

Si consiglia di pulire di tanto in tanto il cassetto del detersivo. Non utilizzare mai detersivi chimici o abrasivi.

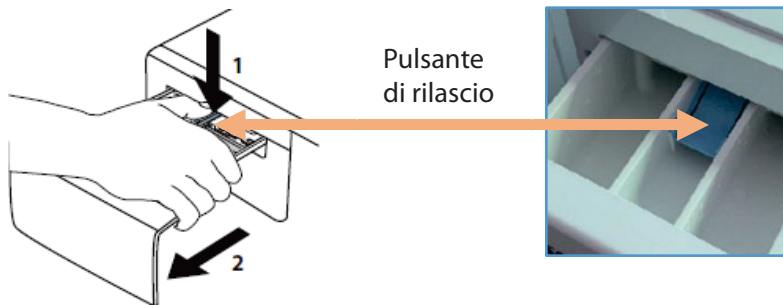

1. Per rimuovere il cassetto, premere il pulsante di sblocco e contemporaneamente estrarre il cassetto dall'apparecchio.
2. Pulire tutte le parti sotto l'acqua corrente utilizzando una spazzola morbida, rimuovendo tutti i residui di detersivo o ammorbidente.
3. Pulire l'incavo del cassetto nell'apparecchio utilizzando una spazzola morbida.
4. Reinstallare il cassetto e spingerlo nuovamente in posizione.

■ Pulizia del filtro della pompa di scarico

Il filtro della pompa di scarico raccoglie fili e piccoli oggetti rimasti nella biancheria. Controllare regolarmente che il filtro sia pulito per garantire il corretto funzionamento della macchina.



AVVERTENZA :

Fare attenzione quando si scarica l'acqua se è calda. Lasciare raffreddare l'acqua prima di pulire il filtro della pompa di scarico. Rischio di scottature!

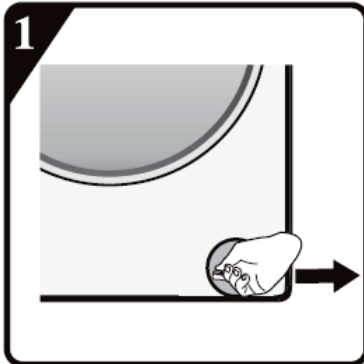

1
Inserire un piccolo cacciavite piatto nell'apertura del coperchio per sollevarlo.

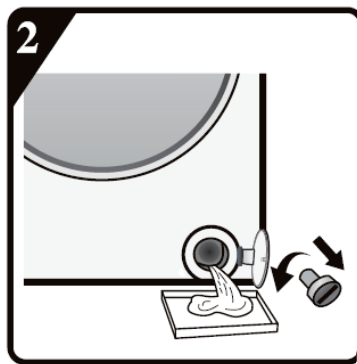

2
Posizionare un contenitore basso e largo sotto il filtro dell'acqua.

Ruotare lentamente il filtro in senso antiorario fino a quando tutta l'acqua non sarà fuoriuscita.

- Una volta che il contenitore è pieno, chiudere il filtro dell'acqua ruotandolo in senso orario. Svuotare il contenitore dei detriti. Ripetere la procedura fino a quando tutta l'acqua non sarà stata scaricata.

Rimuovere il filtro dell'acqua e pulirlo sotto l'acqua corrente utilizzando una spazzola morbida.

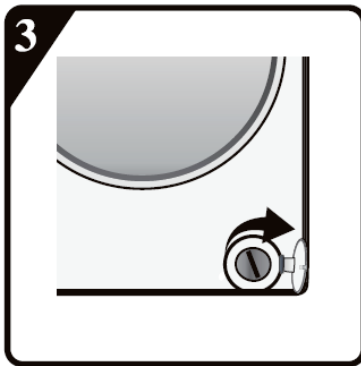

3
Reinserire il filtro dell'acqua nell'apparecchio ruotandolo in senso orario.

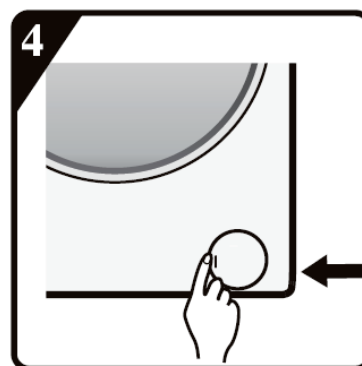

4
Chiudere il coperchio fino a sentire uno scatto.

RISOLUZIONE DEI PROBLEMI

Problemi	Possibile causa	Possibili soluzioni
La lavatrice non si avvia.	Lo sportello non è chiuso correttamente.	Chiudere bene lo sportello.
	Collegamento scadente all'alimentazione elettrica.	Controllare il collegamento all'alimentazione elettrica.
	Interruzione di corrente	Controllare l'alimentazione.
	La macchina non è stata accesa.	Accenderla.
Una volta completato il programma, il detersivo rimane nel cassetto.	Il detersivo non è del tipo poco schiumogeno.	Controllare che il detersivo sia adatto.
	Uso eccessivo di detersivo	Ridurre la quantità di detersivo nel cassetto.
La lavatrice vibra o è troppo rumorosa.	Non tutti i bulloni per il trasporto sono stati rimossi.	Rimuovere tutti i bulloni per il trasporto.
	La lavatrice è posizionata su una superficie irregolare o non è in piano.	Assicurarsi che la lavatrice sia posizionata su una superficie piana e livellata.
	Il carico della macchina supera la capacità massima.	Ridurre la quantità di biancheria nel cestello.
La lavatrice non scarica e/o non centrifuga.	Il tubo di scarico è bloccato.	Sbloccare il tubo di scarico.
	Il filtro è parzialmente bloccato.	Sbloccare il filtro.
	Carico sbilanciato	Aggiungere indumenti o avviare nuovamente il programma di centrifuga.
Il risultato del lavaggio non è buono.	Il bucato era troppo sporco per il programma selezionato.	Selezionare un programma adatto.
	La quantità di detersivo utilizzata non è adeguata.	Utilizzare più o meno detersivo seguendo le istruzioni del produttore.
	Nella lavatrice sono stati inseriti tanti indumenti da superare la capacità massima.	Non superare la capacità massima della macchina.
L'apparecchio non asciuga o non asciuga correttamente.	Il rubinetto non è aperto.	Aprire il rubinetto dell'acqua
	Il filtro della pompa di scarico è bloccato.	Assicurarsi che il filtro della pompa di scarico non sia intasato.
	Macchina caricata in modo errato	Ridurre il carico di biancheria.
	Impostazione del ciclo non corretta	Assicurarsi di aver impostato il ciclo corretto.

Codici di errore

Display	Causa	Soluzione
F01	Guasto all'ingresso dell'acqua	Controllare se la pressione dell'acqua è troppo bassa. Controllare se il tubo di ingresso è attorcigliato. Controllare se il filtro di ingresso è ostruito. Controllare se il tubo di ingresso è congelato. Dopo aver rimosso il guasto, premere Départ/Pause .

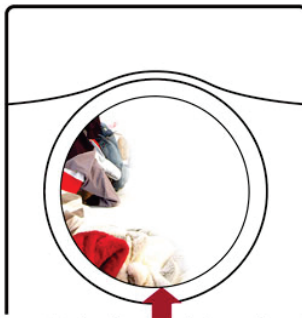
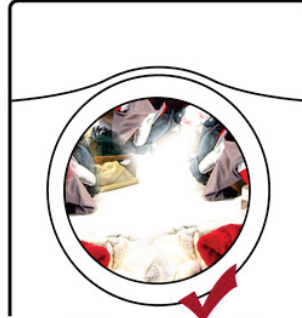
F03	Scarico difettoso	Controllare se il tubo di scarico è attorcigliato. Controllare se il filtro dell'acqua è ostruito. IMPORTANTE! Prima di scaricare l'acqua dall'apparecchio, assicurarsi che si sia raffreddata.
F13	Guasto alla serratura dello sportello	Avviare il programma per 20 secondi e sbloccare lo sportello per verificare se è chiuso. Aprirlo o chiuderlo di nuovo. Dopo aver rimosso il guasto, premere Départ/Pause .
F14	Guasto allo sblocco dello sportello	Premere Départ/Pause . L'apparecchio proverà ad aprire lo sportello. L'allarme non verrà disattivato finché lo sportello non verrà sbloccato. Oppure ruotare il selettore programmi in posizione Off per 3 secondi per spegnere la macchina. Quando si seleziona il programma desiderato per avviare la macchina, l'allarme viene rimosso.
F24	Traboccamento o troppa schiuma	Rimuovere il codice di errore premendo Départ/Pause e poi scolare l'acqua. Selezionare e avviare il programma desiderato.
Altri codici di errore da F04 a F98	Il modulo elettronico è guasto.	Ruotare il selettore programmi in posizione Off  per 3 secondi per spegnere la macchina. Dopo aver rimosso il guasto, premere Départ/Pause .
Unb	Allarme carico sbilanciato	<div style="display: flex; justify-content: space-around; align-items: center;"> <div style="text-align: center;">  <p>Unbalanced Load</p> </div> <div style="text-align: center;">  <p>Balanced Load</p> </div> </div> <p>Se il bucato si attorciglia, separare e riorganizzare il carico. Se il bucato nel cestello è troppo leggero, aggiungere due o più asciugamani.</p>

Se il guasto si ripresenta, staccare la spina e contattare il servizio post-vendita.

Apertura sportello di emergenza

In caso di mancata apertura dello sportello a causa di un'interruzione di corrente o altre circostanze particolari, è possibile utilizzare il grilletto di sblocco di emergenza sullo sportello della pompa di drenaggio per l'apertura di emergenza.

Prima di aprire lo sportello:



ATTENZIONE!

Rischio ustioni! Assicurarsi che la temperatura dell'acqua non sia troppo alta e che il bucato non scotti. Se necessario, attendere che si raffreddi.



ATTENZIONE!

Rischio di infortuni! Assicurarsi che il tamburo non ruoti. Se necessario, attendere che il tamburo smetta di ruotare.

Per aprire lo sportello, procedere come segue:

1. Assicurarsi che l'apparecchio sia spento e scollegato dalla presa elettrica.
2. Aprire il coperchio del filtro della pompa di scarico.
3. Tenere premuto verso il basso il grilletto di sblocco di emergenza e contemporaneamente aprire lo sportello dell'apparecchio.
4. Estrarre la biancheria e chiudere lo sportello dell'apparecchio.
5. Chiudere il coperchio del filtro.

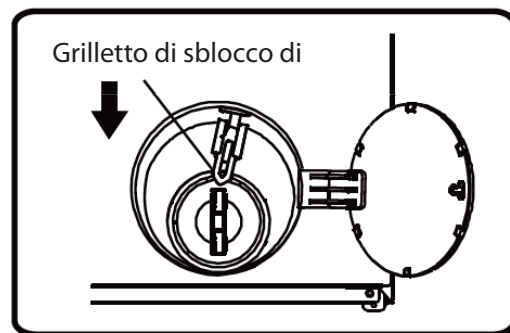

Scheda informativa del prodotto

REGOLAMENTO DELEGATO (UE) 2019/2014 DELLA COMMISSIONE per quanto riguarda l'etichettatura energetica delle lavatrici per uso domestico e delle lavasciuga biancheria per uso domestico

Marchio o nome del fornitore: Etablissements Darty & fils © | TECNOLEC

Indirizzo del fornitore: 9 Rue des Bateaux-Lavois, 94200 Ivry-sur-Seine, France

Identificativo del modello: TECWD85AD

Parametri generali del prodotto:

Parametro	Valore		Parametro	Valore	
Capacità nominale (kg)	Capacità nominale (b)	5,0	Dimensioni in cm	Altezza	85
	Capacità nominale di lavaggio (a)	8,0		Larghezza	60
Indice di efficienza energetica	IEE _w ^(a)	51,6		Classe di efficienza energetica	IEE _w ^(a)
	IEE _{WD} ^(b)	67,0	IEE _{WD} ^(b)		D
Indice di efficienza di lavaggio	I _w ^(a)	1,031	Efficacia di risciacquo (g/kg di tessuti asciutti)	I _R ^(a)	4,5
	J _w ^(b)	1,031		J _R ^(b)	4,5
Consumo di energia in kWh per ciclo, per il ciclo di lavaggio della lavasciuga biancheria per uso domestico con il programma eco 40-60 in una combinazione di carichi pieni e parziali. Il consumo effettivo di energia dipende dalle modalità d'uso dell'apparecchio	0,469		Consumo di energia in kWh per ciclo, per il ciclo di lavaggio e asciugatura della lavasciuga biancheria per uso domestico in una combinazione di carichi pieni e mezzi carichi. Il consumo effettivo di energia dipende dalle modalità d'uso dell'apparecchio.	2,660	
Consumo di acqua in litri per ciclo, per il programma eco 40-60 in una combinazione di carichi pieni e parziali. Il consumo effettivo di acqua dipende dalle modalità d'uso dell'apparecchio e dalla durezza dell'acqua	42		Consumo di acqua in litri per ciclo, per il ciclo di lavaggio e asciugatura della lavasciuga biancheria per uso domestico in una combinazione di carichi pieni e mezzi carichi. Il consumo effettivo di acqua dipende dalle modalità d'uso dell'apparecchio e dalla durezza dell'acqua.	80	
Temperatura massima all'interno dei tessuti trattati (°C) per il ciclo di lavaggio della lavasciuga biancheria	Capacità nominale di lavaggio	34	Temperatura massima all'interno dei tessuti trattati (°C) per il ciclo di lavaggio della lavasciuga biancheria per uso domestico con il ciclo	Capacità nominale	26
	Metà	30		Metà	26
	Un quarto	25			

per uso domestico con il programma eco 40-60			di lavaggio e asciugatura		
Velocità di centrifuga (giri/min) ^(a)	Capacità nominale di lavaggio	1400	Contenuto ponderato di umidità residua (%) ^(a)	53,0	
	Metà	1400			
	Un quarto	1400			
Durata del programma eco 40-60 (ore:min)	Capacità nominale di lavaggio	3:26	Classe di efficienza della centrifuga ^(a)	B	
	Metà	2:48			
	Un quarto	2:48			
Emissioni di rumore aereo durante la fase di centrifuga per il ciclo di lavaggio eco 40-60 alla capacità nominale di lavaggio (dB(A) re 1 pW)	74	Durata del ciclo di lavaggio e asciugatura (ore:min)	Capacità nominale	11:30	
			Metà	8:00	
Tipo	a libera installazione	Classe di emissioni di rumore aereo nella fase di centrifuga del programma eco 40-60 alla capacità nominale di lavaggio	B		
Modo spento (W) (se del caso)	0,49	Modo stand-by (W) (se del caso)	-		
Avvio ritardato (W) (se del caso)	3,70	Modo stand-by in rete (W) (se del caso)	-		
Durata minima della garanzia offerta dal fornitore: 24 mesi					
Questo prodotto è stato progettato per liberare ioni d'argento durante il ciclo di lavaggio		NO			
Informazioni supplementari:					
Link al sito web del fornitore dove si trovano le informazioni di cui all'allegato II, punto 9, del regolamento (UE) 2019/2023 della Commissione: https://www.madocumentationreparation.com					

^(a) Per il programma eco 40-60.

^(b) Per il ciclo di lavaggio e asciugatura.

Per trovare le informazioni sul modello nel database dei prodotti:

fare clic sul collegamento

<https://eprel.ec.europa.eu/screen/product/washerdryers2019/2265203>

Valori per i seguenti programmi:

Il programma eco 40-60 alla capacità nominale	
(a) Capacità nominale in Kg:	8 kg
(b) durata del programma, espressa in ore e minuti:	3:26
(c) consumo energetico, espresso in kWh/ciclo:	0,740 kWh/ciclo
(d) consumo di acqua, espresso in litri/ciclo:	55 L/ciclo
(e) temperatura massima raggiunta per almeno 5 minuti all'interno della biancheria trattata nel ciclo di lavaggio, espressa in gradi centigradi:	34°C

(f) contenuto di umidità rimanente dopo il ciclo di lavaggio, espresso in percentuale di contenuto di acqua e velocità di centrifuga alla quale è stato raggiunto:	53% 1400 giri/min
--	----------------------

Programma eco 40-60 a metà della capacità nominale	
(a) Capacità nominale in Kg:	4 kg
(b) durata del programma, espressa in ore e minuti:	2:48
(c) consumo energetico, espresso in kWh/ciclo:	0,372 kWh/ciclo
(d) consumo di acqua, espresso in litri/ciclo:	40 L/ciclo
(e) temperatura massima raggiunta per almeno 5 minuti all'interno della biancheria trattata nel ciclo di lavaggio, espressa in gradi centigradi:	30°C
(f) contenuto di umidità rimanente dopo il ciclo di lavaggio, espresso in percentuale di contenuto di acqua e velocità di centrifuga alla quale è stato raggiunto:	53% 1400 giri/min

Programma eco 40-60 a un quarto della capacità nominale	
(a) Capacità nominale in Kg:	2 kg
(b) durata del programma, espressa in ore e minuti:	2:48
(c) consumo energetico, espresso in kWh/ciclo:	0,250 kWh/ciclo
(d) consumo di acqua, espresso in litri/ciclo:	30 L/ciclo
(e) temperatura massima raggiunta per almeno 5 minuti all'interno della biancheria trattata nel ciclo di lavaggio, espressa in gradi centigradi:	25° C
(f) contenuto di umidità rimanente dopo il ciclo di lavaggio, espresso in percentuale di contenuto di acqua e velocità di centrifuga alla quale è stato raggiunto:	53% 1400 giri/min

Programma a 20 °C alla capacità nominale per questo programma	
(a) Capacità nominale in Kg:	8 kg
(b) durata del programma, espressa in ore e minuti:	1:50
(c) consumo energetico, espresso in kWh/ciclo:	0,190 kWh/ciclo
(d) consumo di acqua, espresso in litri/ciclo:	65 L/ciclo
(e) temperatura massima raggiunta per almeno 5 minuti all'interno della biancheria trattata nel ciclo di lavaggio, espressa in gradi centigradi:	21° C
(f) contenuto di umidità rimanente dopo il ciclo di lavaggio, espresso in percentuale di contenuto di acqua e velocità di centrifuga alla quale è stato raggiunto:	55% 1400 giri/min

Un programma cotone a temperatura nominale superiore o pari a 60 °C (se presente) alla capacità nominale per questo programma	
Coton 	
(a) Capacità nominale in Kg:	8 kg
(b) durata del programma, espressa in ore e minuti:	3:29
(c) consumo energetico, espresso in kWh/ciclo:	1,180 kWh/ciclo
(d) consumo di acqua, espresso in litri/ciclo:	68 L/ciclo
(e) temperatura massima raggiunta per almeno 5 minuti all'interno della biancheria trattata nel ciclo di lavaggio, espressa in gradi centigradi:	57°C
(f) contenuto di umidità rimanente dopo il ciclo di lavaggio, espresso in percentuale di contenuto di acqua e velocità di centrifuga alla quale è stato raggiunto:	53% 1400 giri/min

Un programma per tessuti diversi dal cotone o un mix di tessuti (se presente) alla capacità nominale per questo programma 	
(a) Capacità nominale in Kg:	4 kg
(b) durata del programma, espressa in ore e minuti:	1:58
(c) consumo energetico, espresso in kWh/ciclo:	0,580 kWh/ciclo
(d) consumo di acqua, espresso in litri/ciclo:	58 L/ciclo
(e) temperatura massima raggiunta per almeno 5 minuti all'interno della biancheria trattata nel ciclo di lavaggio, espressa in gradi centigradi:	38°C
(f) contenuto di umidità rimanente dopo il ciclo di lavaggio, espresso in percentuale di contenuto di acqua e velocità di centrifuga alla quale è stato raggiunto:	55% 1400 giri/min

Un programma per il lavaggio rapido di biancheria leggermente sporca (se presente) alla capacità nominale per questo programma 	
(a) Capacità nominale in Kg:	1 kg
(b) durata del programma, espressa in ore e minuti:	0:30
(c) consumo energetico, espresso in kWh/ciclo:	0,310 kWh/ciclo
(d) consumo di acqua, espresso in litri/ciclo:	18 L/ciclo
(e) temperatura massima raggiunta per almeno 5 minuti all'interno della biancheria trattata nel ciclo di lavaggio, espressa in gradi centigradi:	38°C
(f) contenuto di umidità rimanente dopo il ciclo di lavaggio, espresso in percentuale di contenuto di acqua e velocità di centrifuga alla quale è stato raggiunto:	55% 800 giri/min

Un programma per tessuti molto sporchi (se presente) alla capacità nominale per questo programma 	
(a) Capacità nominale in Kg:	8 kg
(b) durata del programma, espressa in ore e minuti:	2:09
(c) consumo energetico, espresso in kWh/ciclo:	0,240 kWh/ciclo
(d) consumo di acqua, espresso in litri/ciclo:	68 L/ciclo
(e) temperatura massima raggiunta per almeno 5 minuti all'interno della biancheria trattata nel ciclo di lavaggio, espressa in gradi centigradi:	20°C
(f) contenuto di umidità rimanente dopo il ciclo di lavaggio, espresso in percentuale di contenuto di acqua e velocità di centrifuga alla quale è stato raggiunto:	53% 1400 giri/min

Per lavasciuga: ciclo di lavaggio e asciugatura alla capacità nominale 	
(a) Capacità nominale in Kg:	5 kg
(b) durata del programma, espressa in ore e minuti:	11:30
(c) consumo energetico, espresso in kWh/ciclo:	3,170 kWh/ciclo
(d) consumo di acqua, espresso in litri/ciclo:	92 L/ciclo
(e) temperatura massima raggiunta per almeno 5 minuti all'interno della biancheria trattata nel ciclo di lavaggio, espressa in gradi centigradi:	26°C
(f) contenuto di umidità rimanente dopo il ciclo di lavaggio, espresso in percentuale di contenuto di acqua e velocità di centrifuga alla quale è stato raggiunto:	2,90% 1400 giri/min

Per lavasciuga: ciclo di lavaggio e asciugatura a metà della capacità nominale	
☀ Lavage et Séchage	
(a) Capacità nominale in Kg:	2,5 kg
(b) durata del programma, espressa in ore e minuti:	8:00
(c) consumo energetico, espresso in kWh/ciclo:	1,900 kWh/ciclo
(d) consumo di acqua, espresso in litri/ciclo:	63 L/ciclo
(e) temperatura massima raggiunta per almeno 5 minuti all'interno della biancheria trattata nel ciclo di lavaggio, espressa in gradi centigradi:	26°C
(f) contenuto di umidità rimanente dopo il ciclo di lavaggio, espresso in percentuale di contenuto di acqua e velocità di centrifuga alla quale è stato raggiunto:	2,90% 1400 giri/min

NOTE

- Il programma eco 40-60 è in grado di lavare insieme, nello stesso ciclo, biancheria di cotone normalmente sporca, lavabile a 40 °C o 60 °C.
- Questo programma viene utilizzato per valutare la conformità alla normativa UE in quanto a ecocompatibilità.
- I programmi più efficienti in termini di consumo energetico sono generalmente quelli che funzionano a temperature più basse e con una durata maggiore.
- Il ciclo di lavaggio e asciugatura è in grado di lavare insieme, nello stesso ciclo, biancheria di cotone normalmente sporca lavabile a 40 °C o 60 °C e di asciugarla in modo tale da poterla riporre immediatamente in un armadio; tale programma viene utilizzato per valutare la conformità alla normativa UE in quanto a ecocompatibilità.
- Se si carica la lavatrice fino alla capacità indicata dal produttore per i rispettivi programmi, si avrà un risparmio di energia e di acqua.
- Il rumore e il contenuto di umidità residua sono influenzati dalla velocità di centrifuga: maggiore è la velocità di centrifuga nella fase di centrifuga, maggiore è il rumore e minore è il contenuto di umidità residua.
- I valori indicati per programmi diversi da quello eco 40-60 e dal ciclo di lavaggio sono puramente indicativi.

Valutazioni	220-240V~, 50Hz 1750W (potenza nominale) 1350W (potenza di asciugatura)
Pressione dell'acqua	0,1 - 1 MPa
Grado di impermeabilità	IPX4

SERVIZIO ASSISTENZA PER RIPARAZIONI E RICAMBI



Non smontare o riparare l'elettrodomestico da soli. Altrimenti si rischiano scosse elettriche ed infortuni

Per accedere a riparazioni professionali e ordinare pezzi di ricambio, richiedere supporto al servizio post-vendita FNAC DARTY.

I ricambi per i vostri elettrodomestici vi saranno consegnati entro 15 giorni lavorativi dal ricevimento dell'ordine.

Disponibilità delle parti di ricambio: un periodo minimo di 10 anni

Da tener presente

Tutti gli elettrodomestici hanno una garanzia di 2 anni.

La garanzia non copre i danni causati da installazione non corretta, modifiche non autorizzate, riparazioni fai da te o riparazioni non professionali.

Recapiti:



www.darty.com



0978 970 970

24 ore al giorno

7 giorni a settimana



9 Rue des Bateaux-Lavois,
94200 Ivry-sur-Seine,
Francia

SMALTIMENTO



■ In qualità di rivenditori responsabili, abbiamo a cuore l'ambiente. Vi invitiamo pertanto a seguire la corretta procedura di smaltimento dell'apparecchio e dei materiali di imballaggio. In questo modo si contribuisce a preservare le risorse naturali e a garantire che il riciclo dei materiali avvenga in modo tale da proteggere la salute e l'ambiente.

L'apparecchio e il suo imballaggio devono essere smaltiti in conformità alle leggi e alle normative locali. Poiché questo apparecchio contiene componenti elettronici, quando raggiunge la fine del suo ciclo di vita, l'apparecchio e i suoi accessori devono essere smaltiti separatamente dai rifiuti domestici.

Per informazioni sullo smaltimento e il riciclo, contattare le autorità locali.

L'apparecchio deve essere portato presso l'isola ecologica o il punto di raccolta locale per il riciclo dei materiali. Alcuni punti di raccolta accettano gli elettrodomestici senza alcun addebito.

Ci scusiamo per eventuali disagi causati da eventuali piccole incongruenze nelle presenti istruzioni, che potrebbero verificarsi a seguito dei miglioramenti e dello sviluppo del prodotto.

Etablissements Darty & fils ©,

9 Rue des Bateaux-Lavois, 94200 Ivry-sur-Seine, France 28/02/2025

Table of Contents

IMPORTANT SAFETY INSTRUCTIONS	1
PRODUCT OVERVIEW	5
INSTALLATION.....	8
BEFORE EACH WASHING.....	11
WASHING AND DRYING	13
PROGRAMME CHART.....	18
ADDITIONAL FUNCTIONS	20
Delay End Function.....	20
Sound Function.....	21
Child Lock Function.....	21
CLEANING AND MAINTENANCE.....	22
TROUBLESHOOTING	24
PRODUCT INFORMATION SHEET.....	27
REPAIR AND SPARE PARTS SERVICE.....	32
DISPOSAL	33

This product has been manufactured and sold under the responsibility of Etablissements Darty et Fils (S.A.S) and the logo are trademarks used under license by Etablissements Darty et Fils (S.A.S) – further information at www.brand.com . All other products, services, companies, trademarks, trade or product names and logos referenced herein are the property of their respective owners.

IMPORTANT SAFETY INSTRUCTIONS

PLEASE READ THE FOLLOWING SAFETY WARNINGS AND THE INSTRUCTIONS CAREFULLY BEFORE USING THE APPLIANCE AND KEEP FOR FUTURE REFERENCE.

Warnings



- **Read the instructions.**
- **This appliance is intended to be used in household and similar applications such as:**
 - **staff kitchen areas in shops, offices and other working environments;**
 - **farm houses;**
 - **by clients in hotels, motels and other residential type environments;**
 - **bed and breakfast type environments;**
 - **areas for communal use in blocks of flats.**
- **If the supply cord is damaged, it must be replaced by the manufacturer, its service agent or similarly qualified persons in order to avoid a hazard.**
- **This appliance can be used by children aged from 8 years and above and persons with reduced physical, sensory or mental capabilities or lack of experience and knowledge if they have been given supervision or instruction concerning use of the appliance in a safe way and understand the hazards involved. Children shall not play with the appliance. Cleaning and user maintenance shall not be made by children without supervision.**
- **CAUTION: Do not connect to the hot water supply.**
- **The openings must not be obstructed by a carpet.**

- The water pressure must not be less than 0.1 MPa and not greater than 1 MPa.
- The new hose-sets supplied with the appliance are to be used; old hose-sets should not be reused.
- Children of less than 3 years should be kept away unless continuously supervised.
- Regarding the detailed instructions concerning the method of cleaning, please see section “CLEANING AND MAINTENANCE” on pages 22-24.
- The maximum mass of dry textile material in kilograms to be used in the appliance is 8 kg (for the wash cycle) and 5 kg (for the wash and dry cycle).
- The tumble dryer is not to be used if industrial chemicals have been used for cleaning.
- The lint trap has to be cleaned frequently.
- Lint must not be allowed to accumulate around the tumble dryer.
- Adequate ventilation has to be provided to avoid the back flow of gases into the room from appliances burning other fuels, including open fires.
- Do not dry unwashed items in the tumble-dryer.
- Items that have been soiled with substances such as cooking oil, acetone, alcohol, petrol, kerosene, spot removers, turpentine, waxes and wax removers should be washed in hot water with an extra amount of detergent before being dried in the tumble dryer.
- Items such as foam rubber (latex foam), shower caps, waterproof textiles, rubber backed articles and clothes or pillows fitted with foam rubber pads should not be dried in the tumble dryer.
- Fabric softeners, or similar products, should be used as specified by the fabric softener instructions.
- Remove all objects from pockets such as lighters and matches.
- **WARNING:** Never stop a tumble dryer before the end of

the drying cycle unless all items are quickly removed and spread out so that the heat is dissipated.

- **WARNING:** The appliance must not be supplied through an external switching device, such as a timer, or connected to a circuit that is regularly switched on and off by a utility.
- Exhaust air must not be discharged into a flue which is used for exhausting fumes from appliances burning gas or other fuels.
- The appliance must not be installed behind a lockable door, a sliding door or a door with hinges on the opposite side to that of the tumble dryer, in such a way that a full opening of the tumble dryer door is restricted.

Safety Precautions

- The appliance is for indoor use only.
- Keep the packing materials of the appliance away from children to avoid hazards.
- Do not plug the appliance to the power supply with wet hands.
- Never touch the appliance with wet hands or feet.
- In the event of any failure, first unplug the appliance and close the water tap. Do not attempt to repair by yourself. Please contact your authorised service agent.
- Do not exceed the maximum loading capacity.
- The glass door becomes very hot during the washing cycle. Keep children and pets away from the appliance whilst it is in operation.
- Never force the door to open when the appliance is running.
- Do not leave children unattended near the appliance since they might lock themselves up into it.
- Always unplug the appliance and turn off the water supply after use.
- Animals and children may climb into the machine. Check

the machine before every operation.

- **The plug must be remained easily accessible after installation of the appliance.**
- **Do not wash articles that have been cleaned in, washed in, soaked in, or dabbed with combustible or explosive substances (such as wax, oil, paint, gasoline, degreasers, dry-cleaning solvents, kerosene, etc.). This may result in fire or explosion.**
- **The appliance shall not be installed in bath room or very wet rooms as well in the rooms with explosive or caustic gases.**

PRODUCT OVERVIEW

Drawer
(for detergent and
fabric softener)

Control panel

Door

Drum

Adjustable feet (4)

Drain filter cover



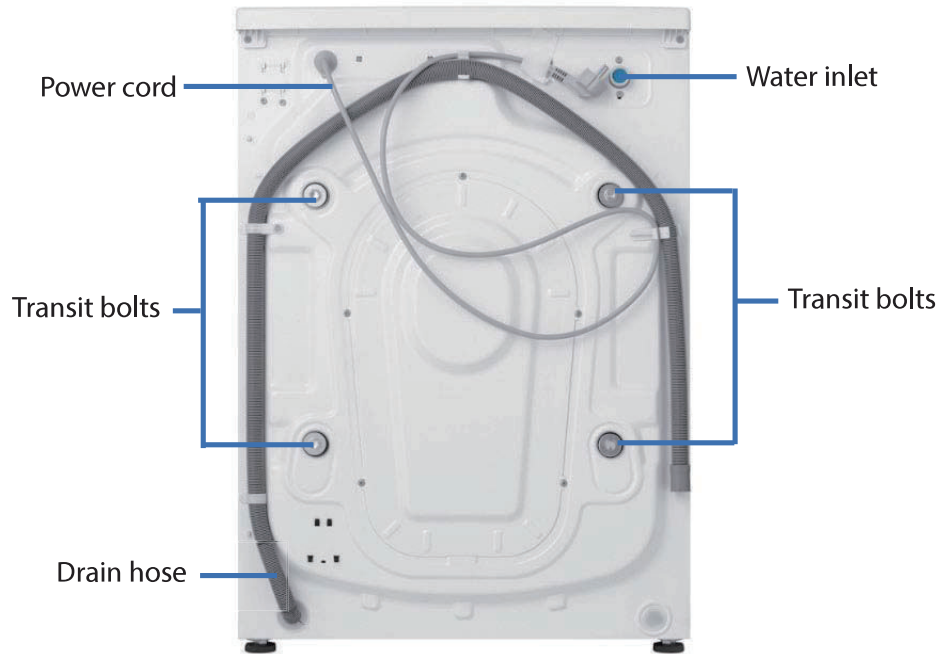

Accessories



Caps



Inlet hose



Bottom plate



U-bend



Wrench

Control panel

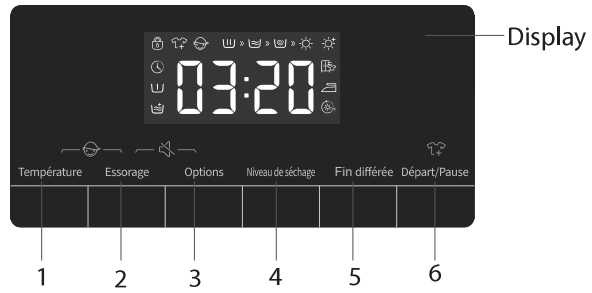
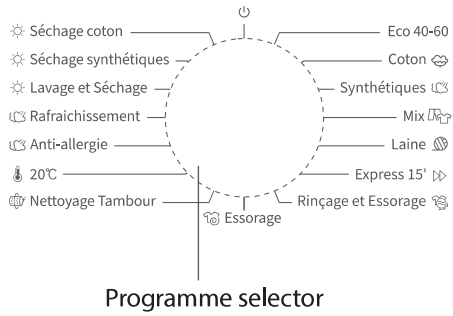

- 1 Temperature button
- 2 Spin button
- 3 Option button
- 4 Dry level button
- 5 Delay end button
- 6 Start/Pause button

- 1 + 2 Child lock function
- 2 + 3 Sound function
- 6 Reload function

Indicators on the display



Displaying washing time, speed, error code, temperature

Door locked	Reload	Child lock	Delay end	Prewash	Extra rinse

Dry level symbols

Extra dry	Cupboard dry	Iron dry	Timed drying

The symbols appear on the display when the related phase is set.

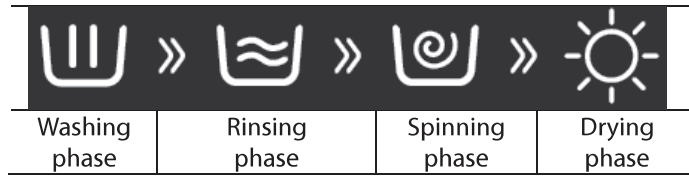

INSTALLATION

■ Removing packing

1. Remove the cardboard box and styrofoam packing.
2. Lift the washing machine and remove the base packing. This will require 2 or more people.
3. Remove the tape securing the power supply cord and drain hose.



WARNING :

Packaging material (e.g. Films, Styrofoam) can be dangerous for children.
There is a risk of suffocation ! **Keep all packaging away from children.**

■ Removing transit bolts

The appliance is fitted with transit bolts to prevent internal damage during transport.
Packing and all transit bolts must be removed before using the appliance.

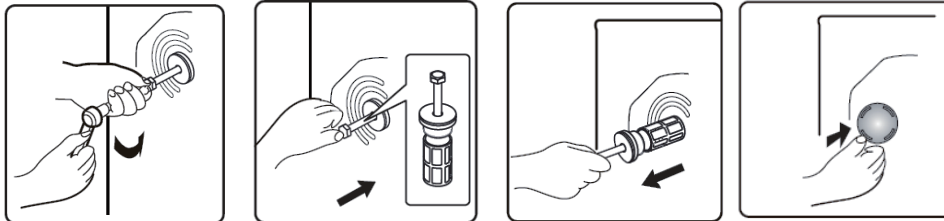

1. Use a wrench to turn the bolt heads anticlockwise until the bolts can be partially withdrawn.
2. Push transit bolts inwards to loosen them.
3. Remove transit bolts and rubber bushes by pulling outwards.
4. Close the holes with the supplied caps.

■ Positioning

Install the appliance on a flat hard floor.

Make sure that air circulation around the appliance is not impeded by carpets, rugs, etc.

Allow at least 2 cm of clearance at each side of the appliance.

Make sure that the appliance does not stand onto the power cord.

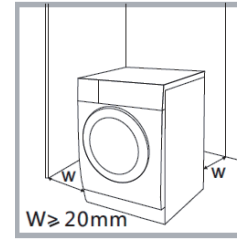

■ Installation location requirements

Before installing the appliance, the location characterised as follows shall be selected:

- Rigid, dry, and level surface
- Avoid direct sunlight
- Sufficient ventilation
- Room temperature is above 0°C.
- Keep far away from heat resources such as coal or gas burning appliances.

■ Levelling the appliance

Levelling the washing machine properly prevents excessive noise and vibration. Install the appliance on a solid and level floor surface.

If the floor is uneven, turn the adjustable feet as required.

- Never put cartons, wooden blocks or similar materials under the feet.

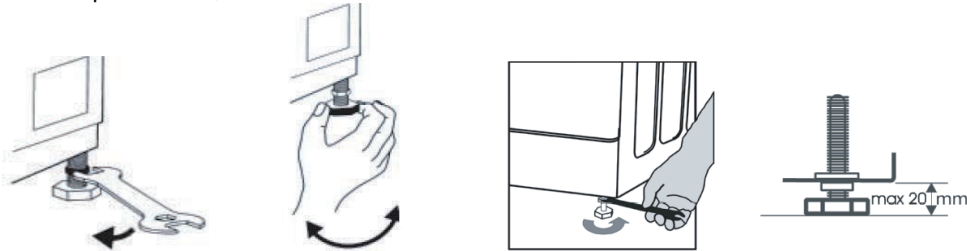

1. Loosen the lock nuts with a spanner.
2. Turn the adjustable feet to adjust the height.
 - Make sure that all four feet are stable and resting on the floor and then check that the appliance is perfectly level using a spirit level.
3. Tighten the lock nuts.

■ Installing the bottom cover

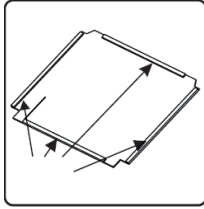

1. Peel off the backing paper from double-sided tapes at four sides of the bottom plate.

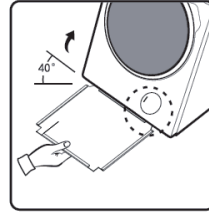

2. Tilt the appliance backwards (tilting angle: 40°) and insert the bottom plate.

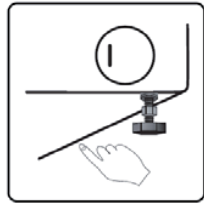

3. Press the double-sided tapes to secure the bottom plate onto the appliance.

Attention: In order to achieve a better performance on the noise level, please ensure you put the “Noise Reduction Bottom Plate” as provided. Please read and follow the installation guide as shown on the noise reduction plate and in instruction manual.

■ Electrical connection

Your washing machine works with 220-240V and 50Hz.

Electrical connections must be carried out by a qualified technician in compliance with the local safety regulations.

Your washing machine must be properly earthed. We will not be held responsible for any damage that may occur as a result of usage without correct earth connection.

Do not use extension leads or multi-sockets.

The appliance must not have an external switching device such as a timer or connected to a circuit that is regularly switched on and off.

Do not pull the plug out of the mains outlet if there is flammable gas around.

■ Connecting the hoses

Connecting the water supply hose



The appliance must be connected to a cold water supply.

Make sure that there is no kink on the hose and that it is not crushed.

1. Screw one end of the inlet hose on the back of the appliance.

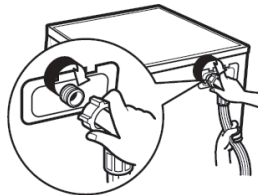

2. Connect the other end of the inlet hose to a 3/4" threaded tap.

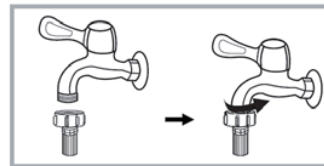

NOTE:

After completing connection, turn on the tap slowly and make sure there are no leak. Do not twist, squash, modify or cut the hose.

Connecting the drain hose

To install the drain hose, please use one of the following methods.

Make sure that the drain hose does not bend, buckle, is not crushed or extended.

- Push the hose firmly into a drainage standpipe.

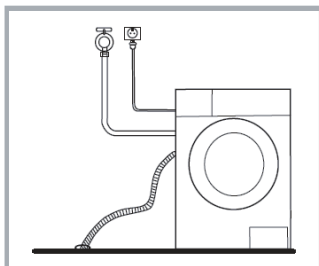

- When installing the drain hose to a sink, secure it tightly with a string.

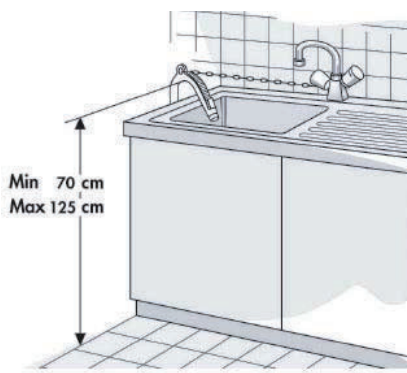

NOTE:

The water drain hose should be mounted at a height of minimum 70cm, maximum 125cm from the ground.

BEFORE EACH WASHING

Rules for separating laundry

- Fabric type / symbol on the wash label (cotton, mixed fibres, synthetic, wool, hand wash items)
- Colour
Separate coloured and white items. Wash new coloured items separately.
- Size
Wash items of different sizes in the same load to improve washing efficiency and distribution of the items in the drum.
- Delicates
Wash delicate items separately.
- Baby articles (baby clothes, towels and napkins) shall be washed separately.
If they are washed together with the adults' clothes, they may be infected. Rinsing times shall be increased to ensure the thorough rinsing and cleaning with no detergent residues left.
- It is suggested that the items that are easily stained such as white socks, collars and sleeves etc. shall be hand washed before being put into washing machine to achieve more ideal washing effects.

Empty pockets



Check all pockets to make sure that they are empty. Items such as nails, hair clip, matches, pens, coins and keys can damage both your appliance and your clothes.

Close all zippers, buttons, and hooks.

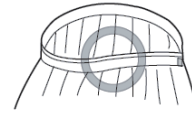
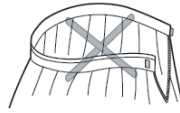

Close zippers, hooks and strings to make sure that these items don't snag on other clothes.
Tie all ribbons or belts.

Detergent

Read instructions on the packet of detergent or other agent, for correct quantity depending on the amount of laundry, degree of soiling, and water hardness.

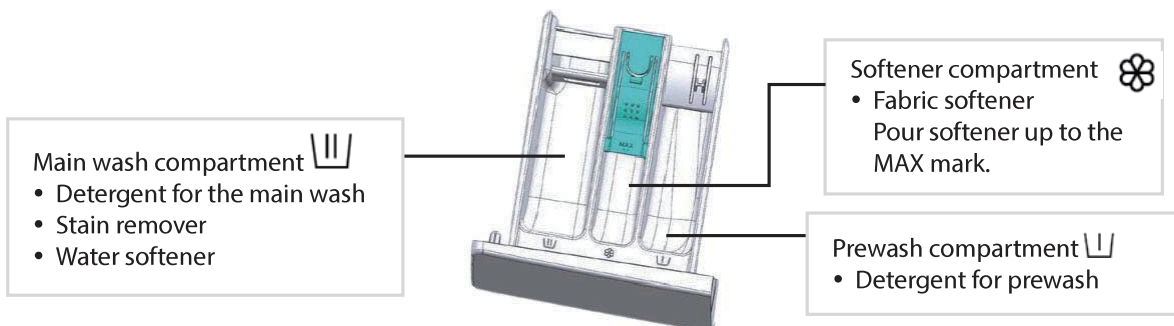

The choice of detergent depends on:

- type of fabric (cottons, easy care/synthetics, delicate items, wool).

Note: Use only specific detergents for washing Wool.

- Colour
- the wash temperature
- degree and type of soiling

Remarks:

- Any whitish residues on dark fabrics are caused by insoluble compounds used in modern phosphate-free powder detergents. If this occurs, shake or brush out the fabric or use liquid detergents.
- Use only detergents and softener specifically produced for domestic washing machines.
- When using descaling agents, dyes or bleaches for the pre-wash, make sure that they are suitable for use in domestic washing machines. Descaler could contain products which could damage your washing machine.
- Do not use any solvents (e.g. turpentine, benzene). Do not machine wash fabrics that have been treated with solvents or flammable liquids.
- Keep detergents and additives in a safe, dry place out of the reach of children.
- To prevent dispensing problems when using highly concentrated powder and liquid detergents, use the special detergent ball or bag supplied with the detergent and place it directly inside the drum.

WASHING AND DRYING

Before the First Wash Cycle

To remove any residual water left during testing by the manufacturer, it is recommended that you carry out a short wash cycle without laundry.

1. Turn on the tap.
2. Close the door.
3. Pour a small quantity of detergent into the Manual Dose liquid/powder detergent compartment for washing phase.
4. Select and start a short programme.

Washing and Drying Your Laundry

1. Open the door to load the articles into the drum.



DO NOT OVERLOAD the appliance.
Observe the load sizes given in the programme chart.
Overloading the appliance will result in washing results.

2. Close the door.



Make sure that no laundry gets stuck between door and door seal.

3. Add detergent and softener.



Pull out the drawer.
Add detergent and softener into the corresponding compartments.
Do not overfilling.

4. Turn the water supply on.

5. Select the desired programme.

Turn the programme dial to select the required programme.

The display will show the washing time.



The programme selector is also used for switching the machine on or off.

For detailed overview of programmes, see Programme Chart.

6. Change temperature, if needed.





Repeatedly press **Température** until the desired temperature is set.

7. Change spin speed, if needed.

Repeatedly press **Essorage** to set the desired spin speed.

8. Select options, if needed.

Repeatedly press **Options** to select the desired option. The options are only available when some programs are selected. The display will show the corresponding symbol when selecting the option.

<p> Pre-wash</p> <p>Select this option for washing heavily soiled laundry. Before washing, the laundry detergent / washing powder can be added to the pre-wash compartment and washing powder must be added to main wash compartment.</p>	 <p>Available for these programmes</p> <ul style="list-style-type: none">Anti-allergie20°CCotonSynthétiquesMix
<p> Extra Rinse</p> <p>Select this option to add an additional rinse cycle to give better rinse result.</p>	 <p>Available for these programmes</p> <ul style="list-style-type: none">Anti-allergie20°CCotonSynthétiquesMixLaineExpress 15'Rinçage et Essorage

9. Select the desired dry level.



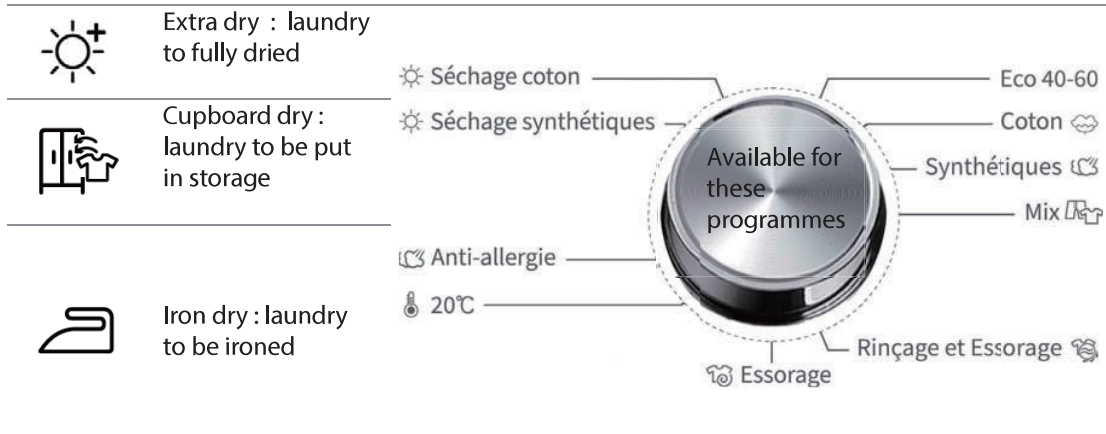

Repeatedly press **Niveau de séchage** to select the desired dry level and The display shows the symbol of the set level:







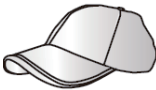

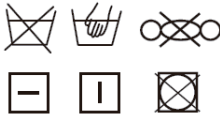

The appliance can sense the weight of clothes to adjust the dry time automatically. Before drying, please confirm whether the clothes can be dried.

Non washable • dry / non-dry clothes

Clothes that can neither be washed nor dried

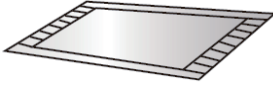
 <p>Leather and fur products (Deformation may be caused.)</p>	 <p>Rayon and its blended products (Discoloration or deformation may be caused.)</p>	 <p>Large thick rubber cushions with carbamate on the back (Damage or fault may be caused.)</p>
 <p>Hats with hard material (It will damage the machine and cause faults.)</p>	 <p>Cushions, pillows, articles with cotton wadding, foam and other sponge materials, carpet cover (Damage or fault may be caused.)</p>	<p>Others: Wrinkled or embossed clothes; crepe fabrics; Easily deformed clothes (suits, jackets, ties and dresses, etc.); Easily fluffing clothes (velvet, velveteen).</p>

Clothes that cannot be dried

 <p>Any of clothes marked by graphic (Clothes may be damaged.)</p>	 <p>Woolen clothes (Shrinkage and fur loss may be caused.)</p>	 <p>Tights, stockings (Damage or deformation may be caused.)</p>	 <p>Sizing clothes</p>
 <p>Cushions or clothes with furs (Damage or fault may be Caused.)</p>	 <p>Quilt (Damage or fault may be caused.)</p>	 <p>Clothes with lace and embroidery, new synthetic fiber (very fine fiber) (Deformation may be caused.)</p>	 <p>Silk</p>

Note !

Non washable dry/non-dry clothes include but not limited to the above clothes.
The wet clothes that are dripping are not suitable for drying, which may cause the machine to alarm !

Time dry

When the display shows the symbol



, repeatedly press

Niveau de séchage

to set the time that suits the fabrics you want to dry. The display will show the set time (30 minutes, 1 hour, 1.5 hours, 2 hours, 3 hours, and 4 hours).



- Before separately drying, please take the dehydrated clothes out of the drum, and put them into the drum after making it loose.
- When few clothes or light clothes are dried, the dry time may be shorter than the set time.
- If the hand-washing clothes requires drying, before drying, please select the spin with high speed according to the clothes types. It is recommended to select the "Spin + Dry Level" programs.

- At the end of drying program, the machine will run for a period of time according to a certain rhythm to loosen the clothes and reduce the wrinkle.
- The overload dry may affect the dry effect, while the excessive dry may cause the wrinkles of clothes. For the chemical fiber clothes, such as the shirts, etc., the iron dry  shall be selected.
- If the clothes with different types of fabrics are dried together, the dry performance may be affected. So it is recommended to properly sort the clothes before drying.

10. Start a programme.

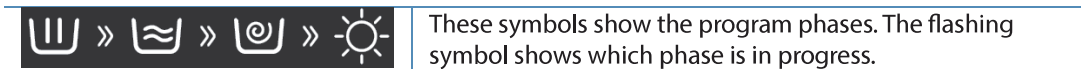

Press **Départ/Pause**. The door will lock and the display will show the symbol .



Automatic weighing

The display will show "----" after starting a programme, indicating that it is weighing automatically. It will adjust the programme duration (hours:minutes) automatically according to weight of laundry.

11. Pause a running programme and open the door, if needed.

- Press **Départ/Pause** to pause a running programme.
- If water level or temperature is not too high, the door locked symbol  will disappear and the display will show the reloading symbol . You can open the door, for example to add more laundry, or to remove laundry which was loaded by mistake.
- Press **Départ/Pause** to proceed with the programme.

12. Change a programme and settings, if needed.

To change the settings of a running programme:



- Turn the programme selector to the Off position  for 3 seconds.
- Select a new programme and change settings.
- Press **Départ/Pause** to start the new programme.

13. At the end of the cycle, the display will show the message "End".

14. Switch off the machine by turning the programme selector to the Off position .

15. Open the door and remove the laundry.













- The door can only be opened when the symbol  disappears.
- Check that the symbol  disappears.
- Open the door and take out the laundry.
- Leave the door ajar to let the interior of the appliance to dry.

















Turn off the tap.

PROGRAMME CHART

Programme	Functions	Max load (kg)	Temperatures	Max. spin speed (rpm)
 Séchage coton Cotton Dry	Drying	5	—	—
 Séchage synthétiques Synthetics Dry	Drying	5	—	—
 Lavage et Séchage Wash and Dry	Wash and dry	5	—	1400
 Rafrachissement Steam Refresh	Drying	2	—	—
 Anti-allergie Allergy Care	Washing	4	40°C, 60°C, 90°C	1400
	Wash and dry	4		
 20°C	Washing	8	20°C	1400
	Wash and dry	5		
 Nettoyage Tambour Drum clean	Wash and dry	—	90°C	800
Eco 40-60	Washing	8	—	1400
	Wash and dry	5		
Coton  Cotton	Washing	8	Cold, 20°C, 30°C, 40°C, 60°C, 90°C	1400
	Wash and dry	5		
Synthétiques  Synthetics	Washing	8	Cold, 20°C, 30°C, 40°C, 60°C	1200
	Wash and dry	5		1400
Mix  Mix	Washing	4	Cold, 20°C, 30°C, 40°C	1400
	Wash and dry			
Laine  Wool	Washing	2	Cold, 20°C, 30°C, 40°C	600
Express 15'  Quick 15'	Washing	1	Cold, 20°C, 30°C, 40°C	800
Rinçage et Essorage  Rinse + Spin	Washing	8	—	1400
	Wash and dry	5		

 Essorage Spin	Spin	8	—	1400
	Spin and dry	5		

Programme	Programme description (Type of load and soil level)	Detergents and Additives		
		Pre-wash I	Main wash II	Softener 
 Séchage coton Cotton Dry	The wet cotton & linen clothes can be dried after being spun.	—	—	—
 Séchage synthétiques Synthetics Dry	The wet chemical fiber clothes can be dried after being spun.	—	—	—
 Lavage et Séchage Wash and Dry	The wash and dry cycle is able to clean normally soiled cotton laundry declared to be washable at 40 °C or 60 °C, together in the same cycle, and to dry it in such a way that it can be immediately stored in a cupboard, and that this programme is used to assess the compliance with the EU ecodesign legislation.	○	●	○
 Rafrachissement Steam Refresh	It is suitable for removing the peculiar smell (such as, the smell of smoke/hot pot/barbecue, etc.) on the clothes.	—	—	—
 Anti-allergie Allergy Care	Programme to effectively extinguishes bacteria in textiles. It is appropriate for clothes of babies who are sensitive to clothes.	○	●	○
 20°C	A washing cycle which is able to clean lightly soiled cotton laundry, at a nominal temperature of 20 °C	○	●	○
 Nettoyage Tambour Drum clean	Programme to remove dirt and bacterial residue that can breed in the machine after it has been used for a period, especially when low temperature washes are used regularly.	—	—	—
Eco 40-60	A washing cycle which is able to clean normally soiled cotton laundry declared to be washable at 40 °C or 60 °C, together in the same cycle	○	●	○
Coton  Cotton	For washing heavily and normally soiled cotton or linen For very heavily soiled garments select the "Prewash" function	○	●	○
Synthétiques  Synthetics	For moderately soiled synthetics, cotton blended fabrics	○	●	○
Mix  Mix	For mixed loads of moderately soiled cotton and synthetic fabrics	○	●	○

Laine  Wool	For machine washable wool. (Refer to the washing label attached to the clothing).	○	●	○
Express 15'  Quick 15'	For washing lightly soiled garments quickly	○	●	○
Rinçage et Essorage  Rinse + Spin	This programme is defaulted to two rinses and spin.	—	—	○
 Essorage Spin	Extra spin with selectable spin speed	—	—	—

● = dosing required / ○ = optional

ADDITIONAL FUNCTIONS

■ Delay End Function

You can use this function to set the programme to finish at a later time. The delay end time can be chosen between 1 and 24 hours in 1-hour increments.

1. Select a programme.
2. Repeatedly press **Fin différée** to select the desired end time.
 - The hours displayed indicates the time the programme will finish.
 - The display will show the symbol .
3. Press **Départ/Pause** to start the programme.
 - The machine will then countdown.

For example, if the programme duration is longer than 2 hours, the minimum delay end function must start from 3 hours.

If the programme duration of your selected programme is 2:28 hours and you set the "Delay End" time to 6 hours, this means your washing programme will finish in 6 hours.

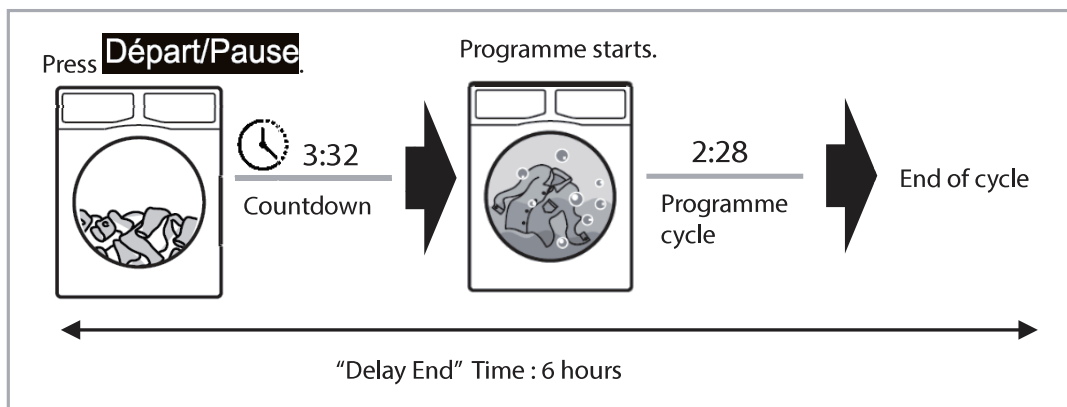

If you want to cancel this function before starting the programme, repeatedly press **Fin différée**

until the symbol  disappears from the display.

To cancel this function after starting the programme, turn off the machine by turning the programme dial to the Off position .

■ Sound Function

You can use this function to turn on or off the sound made when pressing the buttons or turning the programme selector.

- Press and hold **Essorage** and **Options** at the same time for about 2 seconds until the display shows "bEEp oFF", indicating the sound is turned off.
- To deactivate this function, press and hold **Essorage** and **Options** at the same time for about 2 seconds. The display shows "bEEp oN".

■ Child Lock Function

To strengthen the safety of children, this machine is equipped with Child Lock Function.

When the programme starts, press and hold **Température** and **Essorage** at the same time for 2 seconds. The display will show the symbol , indicating that the function is activated. When the function is activated, all function buttons will be locked.

To deactivate this function, press and hold **Température** and **Essorage** at the same time for 2 seconds again. The symbol  will disappear from the display.

- When you turn the machine off by rotating the programme selector to the Off position , the child lock function is deactivated.
- After the programme ends, the child lock will automatically unlock.

CLEANING AND MAINTENANCE



WARNING :

Always unplug the appliance and turn off the water tap before cleaning and maintenance.

■ Cleaning the Machine Housing

Wipe with a soft, damp cloth.

Do not use chemical or abrasive cleaning agents.

Immediately remove washing and cleaning agent residue.

■ Cleaning the Drum

Any rust stains left inside the drum by metal articles must be removed immediately using chlorine-free detergents. Never use steel wool for cleaning the drum !

To descale the drum, run the Drum Clean cycle with the descaling agent according to the manufacturer's instructions for correct detergent dosage.

■ Cleaning the Door Seal and Glass

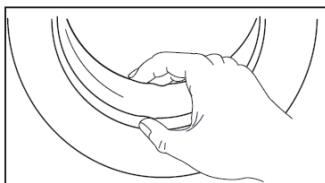

Wipe the glass and seal after each wash to remove lint and stains. If lint builds up it can cause leakages.

Remove any coins, buttons and other objects from the seal after each wash.

Clean the Door Seal and Glass every month to ensure the normal operation of the machine.

■ Cleaning the Inlet Filter



NOTE :

Clean the inlet filter if water is not supplied properly.

If water is very hard or contains traces of lime deposit, the water inlet filter may become clogged. It is recommended to clean the inlet filter from time to time.

1. Close water tap and unscrew the inlet hose.

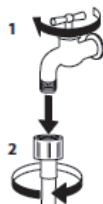

2. Clean the mesh filter at the hose end carefully with a fine brush.



3. Unscrew the inlet hose on the back of the appliance by hand. Pull out the mesh filter from the valve on the back of the appliance with pliers and carefully clean it under running water.

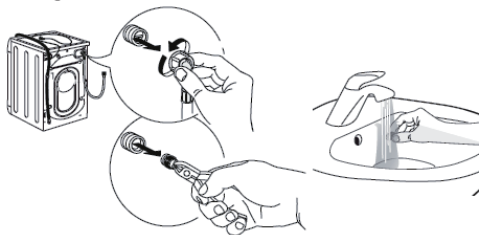

4. Insert the mesh filter back in the appliance. Connect the inlet hose to the water tap and appliance. Open the water tap and check that all connections are tight.

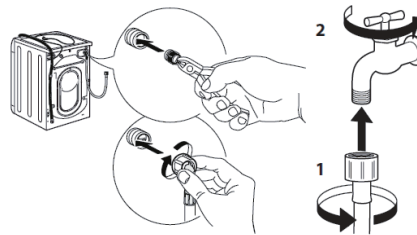

■ Cleaning the Detergent Drawer



NOTE :

It is recommended to clean the detergent drawer from time to time. Never use chemical or abrasive cleaning agents.

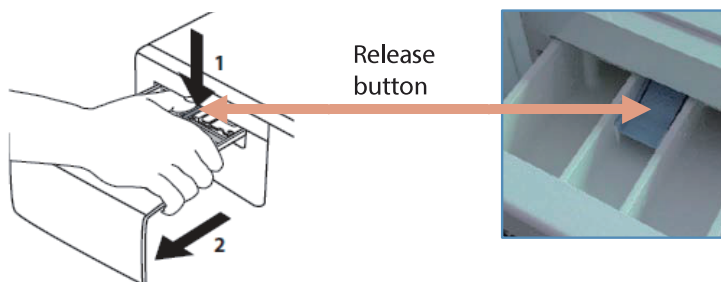

1. Remove the drawer by pressing on the release button and at the same time pulling the drawer out of the appliance.
2. Clean all parts under running water using a soft brush, removing all detergent or softener residues.
3. Clean the drawer recess in the appliance using a soft brush.
4. Reinstall the drawer and push it back into position.

■ Cleaning the Drain Pump Filter

The drain pump filter collects threads and small objects left in the laundry. Check regularly that the filter is clean to ensure smooth running of your machine.



WARNING :

Be careful when draining if the water is hot. Allow the water to cool down before cleaning the drain pump filter. Risk of scalding !

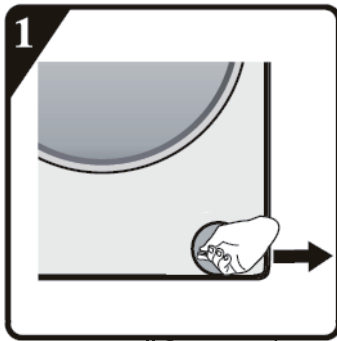

1
Insert a small flat screwdriver into the opening on the cover to pry open the cover.

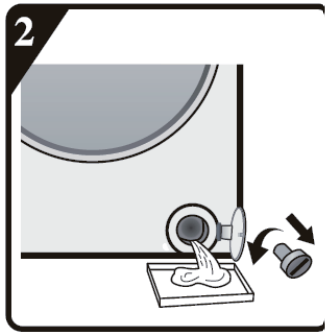

2
Place a low and wide container under the water filter.
Slowly turn the filter anticlockwise until all the water has come out.

- Once the container is full, close the water filter by turning it clockwise. Empty the container. Repeat the procedure until all the water has been drained.

Remove the water filter and clean it under running water with a soft brush.

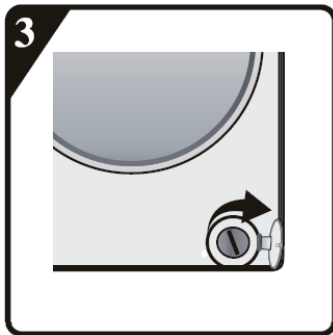

3
Insert the water filter back in the appliance by turning it clockwise.

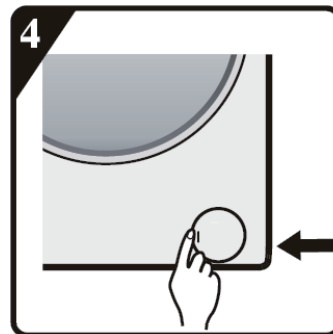

4
Close the cover until a click is heard.

TROUBLESHOOTING

Problems	Possible Cause	Possible Solutions
The washing machine will not start.	The door is not properly closed.	Close the door properly.
	Poor connection to the power supply.	Check connection to the power supply.
	Power failure	Check the power supply.
	Machine has not been switched on.	Switch the machine on.
Detergent remains in the drawer after the program is complete.	The detergent is not a low suds type.	Check if the detergent is appropriate.
	Excessive use of detergent	Reduce amount of detergent in the detergent drawer.
Washing machine vibrates or is too noisy.	Not all transit bolts have been removed.	Remove all transit bolts.
	Washing machine is located on an uneven surface or is not level.	Make sure the washing machine is set on an even surface and levelled.
	Machine load is over the maximum capacity.	Reduce amount of laundry in the drum.

The washing machine does not drain and/or spin.	Drain hose is blocked.	Unblock the drain hose.
	The filter is blocked.	Unblock the filter.
	Unbalance of the laundry	Add clothes or run a spinning program again.
The washing result is not good.	Your laundry was too dirty for the program you selected.	Select a suitable program.
	The amount of detergent used is not appropriate.	Use more or less detergent following the manufacturer's instructions.
	Clothes exceeding the maximum capacity have been filled in your machine.	Do not exceed the maximum capacity of your machine.
The appliance does not dry or does not dry correctly.	Tap is not turned on.	Turn the water tap on
	Drain pump filter is blocked.	Make sure the drain pump filter is not clogged.
	Machine loaded incorrectly	Reduce the laundry load.
	Incorrect cycle setting	Make sure you have set the correct cycle.

Error Codes

Display	Cause	Solution
F01	Water Inlet fault	Check if the water pressure is too low. Check if the inlet hose is knotted. Check if the inlet filter is blocked. Check if the inlet hose is frozen. After fault is removed, press Départ/Pause .
F03	Drainage fault	Check if the drain hose is knotted. Check if the water filter is blocked. IMPORTANT: Ensure that the water has cooled before draining the appliance.
F13	Door lock fault	Start program for 20 sec and unlock the door to check whether the door is closed. Open or close it again. After fault is removed, press Départ/Pause .
F14	Door unlock fault	Press Départ/Pause . The appliance will try to open the door. The alarm will not be removed until the door is unlocked. Or turn the programme selector to the Off position for 3 seconds to turn off the machine. Choose the desired programme to start the machine and the alarm will be removed.
F24	Overflow or too much foam	Remove the error code by pressing Départ/Pause and then drain water. Select and start the required program.
Other error codes F04 to F98	Electronic module fails.	Turn the programme selector to the Off position  for 3 seconds to turn off the machine. After fault is removed, press Départ/Pause .

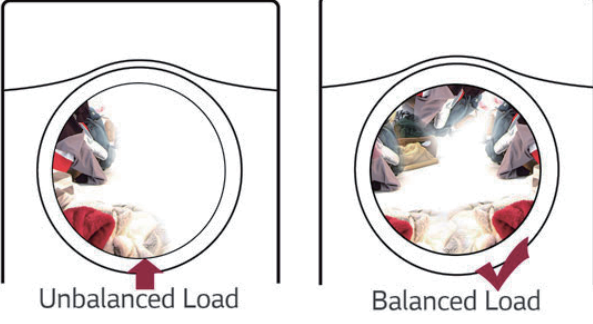
Unb	Unbalance alarm	 <p data-bbox="747 556 1347 672">If laundry winding occurs, separate and rearrange laundry load. If the laundry in the drum is too lightweight, add two or more towels.</p>
-----	-----------------	---

If fault occurs again, unplug the appliance and contact the after-sales service.

Emergency door opening

In case of failure to open the door due to power outage or other special circumstances, the emergency unlock trigger at the drainage pump door can be used for emergency opening.

Before opening the door:



CAUTION !

Risk of burns ! Make sure that the water temperature is not too high and the laundry is not hot. If necessary, wait until they cool down.



CAUTION !

Risk of injury ! Make sure that the drum is not rotating. If necessary, wait until the drum stops rotating.

To open the door, proceed as follows:

1. Ensure that the appliance is switched off and unplugged from the main socket.
2. Open the cover of drain pump filter.
3. Keep the emergency unlock trigger pulled downward and at the same time, open the appliance door.
4. Take out the laundry and then close the appliance door.
5. Close the filter cover.

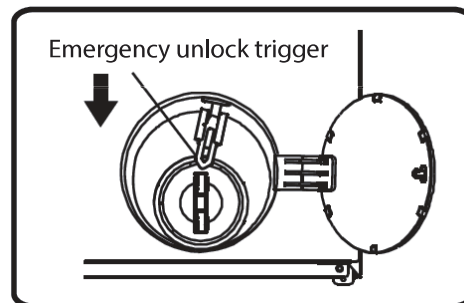

Product Information Sheet

COMMISSION DELEGATED REGULATION (EU) 2019/2014 with regard to energy labelling of household washing machines and household washer-dryers

Supplier's name or trade mark: Etablissements Darty & fils © | TECNOLEC

Supplier's address: 9 Rue des Bateaux-Lavois, 94200 Ivry-sur-Seine, France

Model identifier: TECWD85AD

General product parameters:

Parameter	Value		Parameter	Value	
Rated capacity(kg)	Rated capacity ^(b)	5,0	Dimensions in cm	Height	85
	Rated washing capacity ^(a)	8,0		Width	60
				Depth	54
Energy Efficiency Index	EEL _w ^(a)	51,6	Energy efficiency class	EEL _w ^(a)	A
	EEL _{WD} ^(b)	67,0		EEL _{WD} ^(b)	D
Washing efficiency index	I _w ^(a)	1,031	Rinsing effectiveness (g/kg dry textile)	I _R ^(a)	4,5
	J _w ^(b)	1,031		J _R ^(b)	4,5
Energy consumption in kWh per cycle, for the washing cycle of the household washer-dryer, using the eco 40-60 programme at a combination of full and partial loads. Actual energy consumption will depend on how the appliance is used	0,469		Energy consumption in kWh per cycle, for the wash and dry cycle of the household washer-dryer at a combination of full and half loads. Actual energy consumption will depend on how the appliance is used.	2,660	
Water consumption in litre per cycle, for the eco 40-60 programme at a combination of full and partial loads. Actual water consumption will depend on how the appliance is used and on the hardness of the water	42		Water consumption in litre per cycle, for the wash and dry cycle of the household washer-dryer at a combination of full and half loads. Actual water consumption will depend on how the appliance is used and on the hardness of the water.	80	
Maximum temperature inside the treated textile (°C) for the washing cycle of the household washer-dryer, using the eco 40-60 programme	Rated washing capacity	34	Maximum temperature inside the treated textile (°C) for the washing cycle of the household washer-dryer, using the wash and dry cycle	Rated capacity	26
	Half	30		Half	26
	Quarter	25			
Spin speed (rpm) ^(a)	Rated washing capacity	1400	Weighted remaining moisture content (%) ^(a)	53,0	
	Half	1400			
	Quarter	1400			

Eco 40-60 programme duration (h:min)	Rated washing capacity	3:26	Spin-drying efficiency class (a)	B	
	Half	2:48			
	Quarter	2:48			
Airborne acoustical noise emissions during the spinning phase for the eco 40-60 washing cycle at rated washing capacity (dB(A) re 1 pW)	74	wash and dry cycle duration (h:min)	Rated capacity	11:30	
			Half	8:00	
Type	free-standing	Airborne acoustical noise emission class for the spinning phase for the eco 40-60 programme at rated washing capacity	B		
Off-mode (W) (if applicable)	0,49	Standby mode (W) (if applicable)	-		
Delay start (W) (if applicable)	3,70	Networked standby (W) (if applicable)	-		
Minimum duration of the guarantee offered by the supplier: 24 months					
This product has been designed to release silver ions during the washing cycle		NO			
Additional information:					
Weblink to the supplier's website, where the information in point 9 of Annex II to Regulation (EU) 2019/2023 is found: https://www.madocumentationreparation.com					

(a) for the eco 40-60 programme

(b) for the wash and dry cycle

To find the model information in the product database :

Click the link

<https://eprel.ec.europa.eu/screen/product/washerdryers2019/2265203>

Values for the following programmes:

The eco 40-60 programme at the rated capacity	
(a) rated capacity in kg:	8 kg
(b) programme duration, expressed in hours and minutes:	3:26
(c) energy consumption, expressed in kWh/cycle:	0,740 kWh/cycle
(d) water consumption, expressed in litres/cycle:	55 L/cycle
(e) maximum temperature reached for minimum 5 minutes inside the laundry being treated in the washing cycle, expressed in degrees centigrade:	34°C
(f) remaining moisture content after the washing cycle, expressed in percentage of water content, and spinning speed at which this was achieved:	53% 1400 rpm

The eco 40-60 programme at half of the rated capacity	
(a) rated capacity in kg:	4 kg
(b) programme duration, expressed in hours and minutes:	2:48
(c) energy consumption, expressed in kWh/cycle:	0,372 kWh/cycle
(d) water consumption, expressed in litres/cycle:	40 L/cycle
(e) maximum temperature reached for minimum 5 minutes inside the laundry being treated in the washing cycle, expressed in degrees centigrade:	30°C
(f) remaining moisture content after the washing cycle, expressed in percentage of water content, and spinning speed at which this was achieved:	53% 1400 rpm

The eco 40-60 programme at a quarter of the rated capacity	
(a) rated capacity in kg:	2 kg
(b) programme duration, expressed in hours and minutes:	2:48
(c) energy consumption, expressed in kWh/cycle:	0,250 kWh/cycle
(d) water consumption, expressed in litres/cycle:	30 L/cycle
(e) maximum temperature reached for minimum 5 minutes inside the laundry being treated in the washing cycle, expressed in degrees centigrade:	25°C
(f) remaining moisture content after the washing cycle, expressed in percentage of water content, and spinning speed at which this was achieved:	53% 1400 rpm

The 20 °C programme at the rated capacity for this programme	
(a) rated capacity in kg:	8 kg
(b) programme duration, expressed in hours and minutes:	1:50
(c) energy consumption, expressed in kWh/cycle:	0,190 kWh/cycle
(d) water consumption, expressed in litres/cycle:	65 L/cycle
(e) maximum temperature reached for minimum 5 minutes inside the laundry being treated in the washing cycle, expressed in degrees centigrade:	21°C
(f) remaining moisture content after the washing cycle, expressed in percentage of water content, and spinning speed at which this was achieved:	55% 1400 rpm

One cotton programme at nominal temperature higher than or equal to 60 °C (if present) at the rated capacity for this programme	
(a) rated capacity in kg:	8 kg
(b) programme duration, expressed in hours and minutes:	3:29
(c) energy consumption, expressed in kWh/cycle:	1,180 kWh/cycle
(d) water consumption, expressed in litres/cycle:	68 L/cycle
(e) maximum temperature reached for minimum 5 minutes inside the laundry being treated in the washing cycle, expressed in degrees centigrade:	57°C
(f) remaining moisture content after the washing cycle, expressed in percentage of water content, and spinning speed at which this was achieved:	53% 1400 rpm



One programme for other textiles than cotton or a mix of textiles (if present) at the rated capacity for this programme 	
(a) rated capacity in kg:	4 kg
(b) programme duration, expressed in hours and minutes:	1:58
(c) energy consumption, expressed in kWh/cycle:	0,580 kWh/cycle
(d) water consumption, expressed in litres/cycle:	58 L/cycle
(e) maximum temperature reached for minimum 5 minutes inside the laundry being treated in the washing cycle, expressed in degrees centigrade:	38°C
(f) remaining moisture content after the washing cycle, expressed in percentage of water content, and spinning speed at which this was achieved:	55% 1400 rpm

One programme for the quick washing of lightly soiled laundry (if present) at the rated capacity for this programme 	
(a) rated capacity in kg:	1 kg
(b) programme duration, expressed in hours and minutes:	0:30
(c) energy consumption, expressed in kWh/cycle:	0,310 kWh/cycle
(d) water consumption, expressed in litres/cycle:	18 L/cycle
(e) maximum temperature reached for minimum 5 minutes inside the laundry being treated in the washing cycle, expressed in degrees centigrade:	38°C
(f) remaining moisture content after the washing cycle, expressed in percentage of water content, and spinning speed at which this was achieved:	55% 800 rpm

One programme for heavily soiled textiles (if present) at the rated capacity for this programme 	
(a) rated capacity in kg:	8 kg
(b) programme duration, expressed in hours and minutes:	2:09
(c) energy consumption, expressed in kWh/cycle:	0,240 kWh/cycle
(d) water consumption, expressed in litres/cycle:	68 L/cycle
(e) maximum temperature reached for minimum 5 minutes inside the laundry being treated in the washing cycle, expressed in degrees centigrade:	20°C
(f) remaining moisture content after the washing cycle, expressed in percentage of water content, and spinning speed at which this was achieved:	53% 1400 rpm

For household washer-dryers: the wash and dry cycle at the rated capacity 	
(a) rated capacity in kg:	5 kg
(b) programme duration, expressed in hours and minutes:	11:30
(c) energy consumption, expressed in kWh/cycle:	3,170 kWh/cycle
(d) water consumption, expressed in litres/cycle:	92 L/cycle
(e) maximum temperature reached for minimum 5 minutes inside the laundry being treated in the washing cycle, expressed in degrees centigrade:	26°C
(f) remaining moisture content after the washing cycle, expressed in percentage of water content, and spinning speed at which this was achieved:	2,90% 1400 rpm

For household washer-dryers: the wash and dry cycle at half of the rated capacity	
☀ Lavage et Séchage	
(a) rated capacity in kg:	2,5 kg
(b) programme duration, expressed in hours and minutes:	8:00
(c) energy consumption, expressed in kWh/cycle:	1,900 kWh/cycle
(d) water consumption, expressed in litres/cycle:	63 L/cycle
(e) maximum temperature reached for minimum 5 minutes inside the laundry being treated in the washing cycle, expressed in degrees centigrade:	26°C
(f) remaining moisture content after the washing cycle, expressed in percentage of water content, and spinning speed at which this was achieved:	2,90% 1400 rpm

NOTES :

- The eco 40-60 programme is able to clean normally soiled cotton laundry declared to be washable at 40 °C or 60 °C, together in the same cycle.
- This programme is used to assess the compliance with the EU ecodesign legislation.
- The most efficient programmes in terms of energy consumption are generally those that perform at lower temperatures and longer duration.
- The wash and dry cycle is able to clean normally soiled cotton laundry declared to be washable at 40 °C or 60 °C, together in the same cycle, and to dry it in such a way that it can be immediately stored in a cupboard, and that this programme is used to assess the compliance with the EU ecodesign legislation.
- Loading the household washing machine up to the capacity indicated by the manufacturer for the respective programmes will contribute to energy and water savings.
- Noise and remaining moisture content are influenced by the spinning speed: the higher the spinning speed in the spinning phase, the higher the noise and the lower the remaining moisture content.
- The values given for programmes other than the eco 40-60 programme and the wash cycle are indicative only.

Ratings	220-240V~, 50Hz 1750W (rated power) 1350W (drying power)
Water pressure	0,1 – 1 MPa
Grade of waterproof	IPX4

REPAIR AND SPARE PARTS SERVICE



Do not disassemble or repair the appliance by yourself. Failure to do so may result in an electric shock or personal injury.

To access to professional repair and order spare parts, please get the support from FNAC DARTY after-sales service.

Spare parts for your appliances will be delivered within 15 working days after having received the order.

Availability of spare parts: a minimum period of 10 years

Please Note !

All appliances have a 2-year warranty.

Warranty does not cover damages caused due to improper installation, unauthorized modification, self-repair or non-professional repair.

Contact us at :



www.darty.com



0978 970 970

24 Hours

7 Days a week



9 Rue des Bateaux-Lavois,
94200 Ivry-sur-Seine,
France

Vanden Borre
in alle vertrouwen

www.vandenborre.be



02 334 00 00

8 AM – 6 PM

Mon to Sat



Slesbroekstraat 101
1600 Sint-Pieters-Leeuw
Belgium

DISPOSAL



As a responsible retailer we care about the environment. As such we urge you to follow the correct disposal procedure for the appliance and packaging materials. This will help conserve natural resources and ensure that it is recycled in a manner that protects health and the environment.

You must dispose of this appliance and its packaging according to local laws and regulations. Because this appliance contains electronic components, the appliance and its accessories must be disposed of separately from household waste when the appliance reaches its end of life.

Contact your local authority to learn about disposal and recycling.
The appliance should be taken to your local collection point for recycling. Some collection points accept appliance free of charge.

We apologise for any inconvenience caused by minor inconsistencies in these instructions, which may occur as a result of product improvement and development.

Etablissements Darty & fils ©,
9 Rue des Bateaux-Lavois, 94200 Ivry-sur-Seine, France 28/02/2025

Déclaration UE de Conformité N°862025020025

*EU Declaration of Conformity
EU- Conformiteitsverklaring
Declaración UE de Conformidad
Declaração UE de Conformidade
Dichiarazione di Conformità UE*

Description du produit –

LAVE LINGE SÉCHANT

Product Description:

WASHER DRYER

Productbeschrijving:

WAS-EN DROOGCOMBINATIE

Descripción del producto:

SECADOR DA MÁQUINA DE LAVAR

Descrição do produto:

LAVASCIUGA BIANCHERIA

Descrizione del prodotto:



Marque –

Tecnolec

Brand /Merk /Marca:

Référence commerciale –

TECWD85AD (SKU: 7915020)

Model number /Modelnummer /

Número de modelo/ Número do modelo/

Numero del Modello:

L'objet de la déclaration décrit ci-dessus est conforme à la législation d'harmonisation de l'Union applicable :

The object of the declaration described above is in conformity with the relevant Union harmonisation legislation:

Het hierboven beschreven voorwerp is in overeenstemming met de desbetreffende harmonisatiewetgeving van de Unie:

El objeto de la declaración descrita anteriormente es conforme con la legislación de armonización pertinente de la Unión:

O objeto da declaração acima descrito está em conformidade com a legislação de harmonização da União aplicável:

L'oggetto della dichiarazione di cui sopra è conforme alla pertinente normativa di armonizzazione dell'Unione:

Reference number

- 2014/30/EU
- 2014/35/EU
- 2009/125/EC
- 2011/65/EU & (EU) 2015/863

Title

EMC Directive (EMC)
 Low Voltage Directive (LVD)
 Eco design requirements for energy-related products (ErP)
 RoHS

EMC:

EN IEC 55014-1:2021
 EN IEC 55014-2:2021
 EN IEC 61000-3-2:2019+A1:2021
 EN 61000-3-3:2013+A1:2019+A2:2021

LVD :

EN 60335-2-7:2010 + A1:2013 + A11:2013 + A2:2019
 EN 60335-2-11:2010 + A11:2012 + A1:2015 + A2:2018
 EN 60335-1:2012 + A11:2014 + A13:2017 + A1:2019 + A14:2019 + A2:2019 + A15:2021
 EN 62233: 2008

ErP :

(EU) 2019/2014
 (EU) 2019/2023
 (EU) 2021/340
 (EU) 2021/341
 EN 60456:2016 + A11:2020
 EN IEC 62512:2020 + A11:2020

La présente déclaration de conformité est établie sous la seule responsabilité du fabricant.

This declaration of conformity is issued under the sole responsibility of the manufacturer.
 Deze conformiteitsverklaring wordt uitsluitend onder de verantwoordelijkheid afgelegd van de fabrikant.
 Esta declaración de conformidad se redacta bajo la exclusiva responsabilidad del fabricante.
 Esta declaração de conformidade é redigida sob a responsabilidade exclusiva do fabricante.
 La presente dichiarazione di conformità è rilasciata sotto la responsabilità esclusiva del fabbricante.

Le responsable de cette déclaration est :

The person responsible for this declaration is:
 De verantwoordelijke persoon voor deze verklaring is:
 La persona responsable de esta declaración es:
 A pessoa responsável por esta declaração é:
 La persona responsabile di questa dichiarazione è:



Signé par et au nom de – Signed for and on behalf of - Firmato a nome e per conto di : **Etablissements Darty & Fils**

Nom – Name - Nome: **Predrag Petricevic**
 Fonction – Function – Funzione: **Directeur du Laboratoire Fnac Darty**



Place, Date / Lieu / Luogo e data:
Ivry-sur-Seine, février 25, 2025

Signé par :

 EA30F3FB8F314D0...

