

PROLINE

SÈCHE-LINGE À POMPE À CHALEUR WARMTEPOMPDROGER

PROHP82



MANUEL D'UTILISATION HANDLEIDING

FR















NL

PT

EN



TABLE DES MATIÈRES

	MISES EN GARDE IMPORTANTES.....	2
	CONSEILS D'ÉCONOMIE D' ÉNERGIE.....	6
	DÉBALLAGE DE L'APPAREIL.....	6
	DESCRIPTION DU PRODUIT.....	7
	AVANT D'INSTALLER L'APPAREIL.....	9
	INSTALLATION.....	9
	CONNEXION ÉLECTRIQUE.....	12
	REMARQUES CONCERNANT L'ENTRETIEN DU LING.....	13
	AVANT LA PREMIÈRE UTILISATION.....	14
	FONCTIONNEMENT DU SÈCHE-LINGE.....	15
	NETTOYAGE ET ENTRETIEN.....	21
	GUIDE DE DEPANNAGE.....	24
	FICHE PRODUIT.....	25
	SPÉCIFICATIONS.....	26
	MISE AU REBUT.....	27

FR

NL

PT

EN

01





MISES EN GARDE IMPORTANTES

MERCI DE BIEN VOULOIR LIRE LES CONSIGNES DE SÉCURITÉ
ATTENTIVEMENT AVANT D'UTILISER L'APPAREIL ET
CONSERVER POUR RÉFÉRENCE ULTÉRIEURE.

Avertissements

-  Lisez la notice d'utilisation.
- Cet appareil est destiné à être utilisé dans des applications domestiques et analogues telles que:
 - les coins cuisines réservés au personnel des magasins, bureaux et autres environnements professionnels;
 - les fermes;
 - l'utilisation par les clients des hôtels, motels et autres environnements à caractère résidentiel;
 - les environnements de type chambre d'hôtes.
- Si le câble d'alimentation est endommagé, il doit être remplacé par le fabricant, son service après-vente ou des personnes de qualification similaire afin d'éviter un danger.
- Cet appareil peut être utilisé par des enfants âgés d'au moins 8 ans et par des personnes ayant des capacités physiques, sensorielles ou mentales réduites ou dénuées d'expérience ou de connaissance, s'ils (si elles) sont correctement surveillé(e)s ou si des instructions relatives à l'utilisation de l'appareil en toute sécurité leur ont été données et si les risques encourus ont été appréhendés.

Les enfants ne doivent pas jouer avec l'appareil.
Le nettoyage et l'entretien par l'utilisateur ne doivent pas être effectués par des enfants sans surveillance.
- La masse maximale de linge sec, en kilogrammes, pour cet appareil est de 8 kg.
- En ce qui concerne les informations détaillées sur la méthode du nettoyage, référez-vous dans la section "NETTOYAGE ET ENTRETIEN" en pages 21-23.
- Mise au rebut de l'appareil :**
Pour éviter toute nuisance envers l'environnement ou la santé





humaine causée par la mise au rebut non contrôlée de déchets électriques, recyclez l'appareil de façon responsable pour promouvoir la réutilisation des ressources matérielles. La mise au rebut doit être faite de façon sûre dans des points de collecte publique prévus à cet effet.

- **Installation et mise en service :**

L'appareil doit être installé sur le sol, sur une surface plane et horizontale en s'assurant que les ouvertures d'aération sont correctement dégagées. Ne jamais essayer de remplacer ou de réparer vous même une partie ou un composant de l'appareil, demandez de l'aide à un personnel professionnel et qualifié, si besoin.

- **Manipulation :**



Toujours manipuler l'appareil avec soin afin d'éviter d'endommager celui-ci.

- Le sèche-linge à tambour ne doit pas être utilisé si des produits chimiques ont été utilisés pour le nettoyage.
- Le collecteur de bourre doit être nettoyé fréquemment.
- Il ne faut pas laisser de la bourre s'accumuler autour du sèche-linge à tambour.
- Une ventilation appropriée doit être fournie afin d'éviter un refoulement, à l'intérieur de la pièce, de gaz provenant d'appareils brûlant d'autres combustibles, y compris les feux ouverts.
- Ne pas sécher dans le sèche-linge à tambour des articles non lavés.
- Il convient que les articles qui ont été salis avec des substances telles que l'huile de cuisson, l'acétone, l'alcool, l'essence, le kérosène, les détachants, la térébenthine, la cire et les substances pour retirer la cire soient lavés dans de l'eau chaude avec une quantité supplémentaire de détergent avant d'être séchés dans le sèche-linge à tambour.
- Il convient que les articles comme le caoutchouc mousse (mousse de latex), les bonnets de douche, les textiles étanches, les articles doublés de caoutchouc et les vêtements ou les oreillers





comprenant des parties en caoutchouc mousse ne soient pas séchés dans le sèche-linge à tambour.

- Il convient d'utiliser les produits assouplissants, ou produits similaires, conformément aux instructions relatives aux produits assouplissants.
- Retirer des poches tous les objets tels que briquets et allumettes.
- MISE EN GARDE: Ne jamais arrêter un sèche-linge à tambour avant la fin du cycle de séchage, à moins que tous les articles ne soient retirés rapidement et étalés, de telle sorte que la chaleur soit dissipée.
- MISE EN GARDE: L'appareil ne doit pas être alimenté par l'intermédiaire d'un interrupteur externe, comme une minuterie, ou être connecté à un circuit qui est régulièrement mis sous tension et hors tension par le fournisseur d'électricité.
- Il convient de maintenir à distance les enfants de moins de 3 ans, à moins qu'ils ne soient sous une surveillance continue.
- Les ouvertures de ventilation ne doivent pas être obstruées par un tapis.
- L'air rejeté ne doit pas être évacué dans une évacuation utilisée pour les fumées rejetées provenant des appareils brûlant du gaz ou d'autres combustibles.
- L'appareil ne doit pas être installé derrière une porte à verrouillage, une porte coulissante ou une porte ayant une charnière du côté opposé à celle du sèche-linge, empêchant ainsi l'ouverture totale du sèche-linge à tambour.
- La fiche de prise de courant doit demeurer facilement accessible après l'installation de l'appareil.
-  Les surfaces sont susceptibles de devenir chaudes au cours de l'utilisation.
-  Danger; Risque d'incendie / Matières inflammables
- MISE EN GARDE: Maintenir dégagées les ouvertures de ventilation dans l'enceinte de l'appareil ou dans la structure d'encastrement.





- MISE EN GARDE: Ne pas endommager le circuit de réfrigération.

Precautions de securite

- Cet appareil n'est pas destine a une utilisation en plein air..
- Ne touchez pas l'appareil avec les mains ou les pieds humides ou mouilles.
- Ne vous appuyez pas sur la porte lors du chargement de la machine et n'utilisez pas la porte pour sou lever ou deplacer la machine.
- N'utilisez pas l'appareil si le filtre a peluches n'est pas en place ou est endommage.
- Debranchez toujours la fiche de la prise electrique murale avant de nettoyer l'appareil.
- Ne continuez pas a faire fonctionner cet appareil s'il semble defectueux.



FR

NL

PT

EN

05





CONSEILS D'ÉCONOMIE D' ÉNERGIE

Pour éviter un temps de séchage trop long et une trop forte consommation d'énergie :

- Assurez-vous que votre linge est complètement essoré avant le séchage.
- Chargez le linge selon la quantité optimale recommandée pour le programme utilisé (voir Tableau des Programmes).
- Assurez-vous que la pièce dans laquelle se trouve le sèche-linge est bien ventilée.
- Assurez-vous que le filtre est propre avant d'utiliser le sèche-linge.

DÉBALLAGE DE L'APPAREIL

- Cet appareil est lourd. Prenez des précautions lorsque vous le déplacez.
- Après avoir déballé l'appareil, assurez-vous qu'il n'est pas endommagé. En cas de doute, n'utilisez pas l'appareil et contactez le service après-vente.
- Tous les matériaux d'emballage doivent être retirés avant l'utilisation.



DESCRIPTION DU PRODUIT

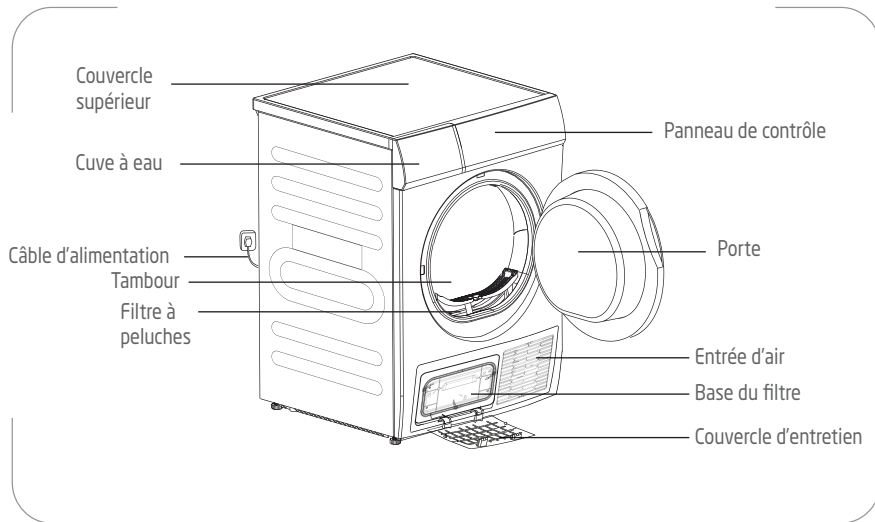

Panneau de contrôle

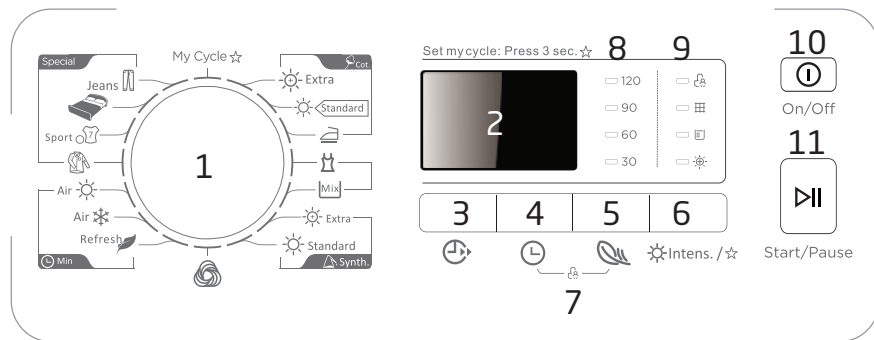

1. Bouton de sélection du programme

2. Affichage

Cet écran est utilisé pour afficher les réglages.

88:88 / 88 Temps de séchage restant estimé / Codes d'erreur

04 Temps restant avant le démarrage différé

3. Bouton de départ différé

FR

NL







PT

EN

07





4.  Bouton de durée
5.  Bouton anti-froissage
6.  Intens. /  Bouton de intensité de séchage / programme favori
7.   Boutons de sécurité enfants
8. Indicateurs lumineux des le temps de anti-froissage
9. Indicateurs lumineux

			
Sécurité enfants	Nettoyer le filtre	Vider le reservoir d'eau	Niveau de séchage

10.  Bouton marche/arrêt
11.  Bouton démarrage/pause





AVANT D'INSTALLER L'APPAREIL

Avant de brancher votre sèche-linge à une prise électrique, vérifiez que la tension indiquée sur la plaque signalétique de votre appareil correspond à la tension du secteur de votre logement. Une tension différente pourrait endommager l'appareil.

La prise du câble d'alimentation sert de dispositif de déconnexion de l'appareil du secteur et doit donc toujours rester accessible. Pour déconnecter l'appareil de la source d'alimentation, éteignez-le et débranchez-le de la prise électrique.

Cet appareil doit être relié à la terre. Le fabricant n'est pas responsable des dommages résultant d'une utilisation de l'appareil sans mise à la terre.

INSTALLATION

- Pour plus de commodité, nous vous recommandons de placer votre sèche-linge près de votre machine à laver.
- Installez le sèche-linge dans un endroit propre où les saletés ne s'accumulent pas.
- Le sèche-linge ne doit pas être installé à proximité d'une plaque de cuisson à gaz, d'une cuisinière, d'un chauffe-eau ou d'un gril, car les flammes des brûleurs pourraient l'endommager.
- Lors de l'installation de l'appareil, assurez-vous que le câble d'alimentation n'est pas coincé ni écrasé.
- Pour limiter au maximum les vibrations et bruit lorsque que le sèche-linge est en marche, placez-le sur une surface plane et ferme.

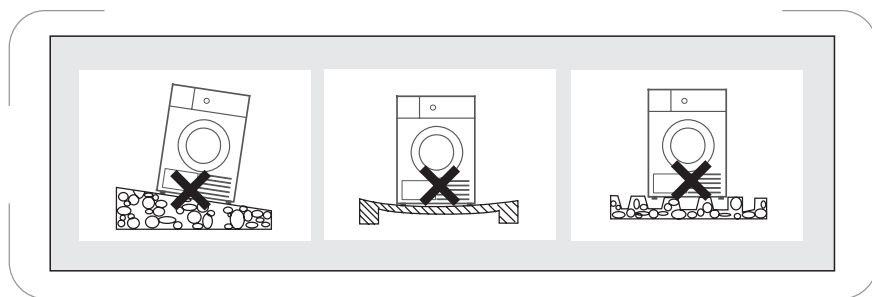

FR

NL

PT

EN

09





Mise à niveau du sèche-linge

Le sèche-linge doit être parfaitement mis à niveau pour assurer un fonctionnement sûr et adéquat.

Si le sèche-linge n'est pas bien à plat sur le sol, ajustez les pieds réglables comme souhaité.

NE placez PAS de pièces en bois, ni aucun autre objet sous les pieds de l'appareil.



Si l'appareil est installé sur un sol recouvert d'une moquette ou sur un tapis, veuillez ajuster les pieds afin de permettre à l'air de circuler librement sous l'appareil.



Ne retirez pas les pieds. Ne réduisez pas l'espace séparant l'appareil et le sol avec des tapis/moquettes à poil long, des morceaux de bois ou des objets similaires. Cela pourrait provoquer une accumulation de chaleur qui nuirait au bon fonctionnement du sèche-linge.



Mettez la machine à niveau en levant ou en baissant les pieds réglables.

N'essayez en aucun cas de corriger les irrégularités du sol en mettant du carton, une cale en bois ou tout autre matériau similaire sous la machine.

Une machine parfaitement mise à niveau est plus stable, plus silencieuse et vibre moins.

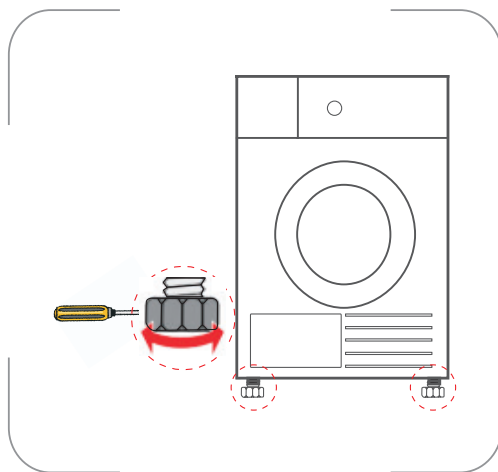



Installation d'accessoires

Si votre sèche-linge comporte les pièces suivantes, veuillez porter des gants et les installer conformément aux instructions ci-dessous.

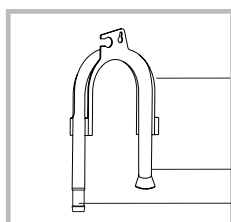

Support de tuyau

Tuyau de vidange

Connecteur

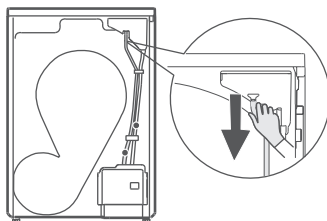

Remontez le tuyau de vidange supérieur.

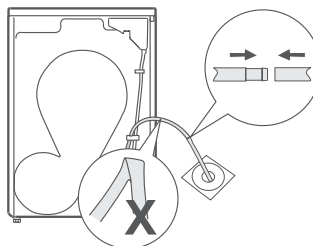

Mettez le tuyau de vidange externe dans le siphon de sol.
(Veuillez à ne pas plier le tuyau de vidange externe).





CONNEXION ÉLECTRIQUE

Danger :

Pour effectuer la connexion électrique de votre appareil :

- La connexion à l'alimentation secteur doit être conforme aux norms et règlements en vigueur.
- N'utilisez pas de rallonge électrique, ni d'adaptateur ou autre dispositif similaire.
- La prise doit être facilement accessible après l'installation de l'appareil.
- En case de doute sur l'état de votre connexion, consultez un électricien qualifié.



Avertissement ! Le fabricant decline toute responsabilité enc as de dommage ou blessure qui pourrait résulter du non respect des consignes de raccordement électrique indiquées ci-dessus.











REMARQUES CONCERNANT L'ENTRETIEN DU LINGE

Étiquettes d'entretien des vêtements

Les vêtements ont leur propre étiquette d'entretien de lavage et il est recommandé de suivre les indications de séchage expliquées ci-dessous.

 Séchage	 Séchage au sèche-linge	 Ne pas sécher dans un sèche-linge	 Ne pas sécher
 Séchage à l'air / Étendre pour sécher	 Faire égoutter	 Sécher à plat	 Sécher à l'ombre
 Nettoyer à sec	 Ne pas nettoyer à sec	 Nettoyer à sec avec n'importe quel solvant	 Nettoyer à sec, solvant à base de pétrole seulement

Les nouveaux vêtements de couleurs foncées doivent être lavés et séchés séparément des vêtements de couleur claire pour éviter que les couleurs ne déteignent et ne décolorent d'autres vêtements ou même les composants en plastique à l'intérieur du sèche-linge. Les fibres de couleur foncée peuvent déteindre sur les vêtements de couleur claire et vice versa.

Caoutchouc et plastiques

Ne faites pas sécher les articles contenant du caoutchouc ou des matières plastiques tels que:

- les tabliers, les bavoirs et les housses de chaise
- les rideaux et les nappes
- les tapis de bain

Vêtements de bébé et chemises de nuit

Vérifiez toujours les étiquettes d'entretien du fabricant.





Vêtements infroissables











Sortez les vêtements infroissables dès que le sèche-linge s'arrête pour réduire les plis.

Vêtements tricotés

Certains vêtements tricotés, tels que les T-shirts et sous-vêtements ont tendance à rétrécir en fonction de leur qualité. Ne faites pas trop sécher ces textiles.

Capacité de charge

Les poids suivants ne sont donnés qu'à titre indicatif.

 Manteaux mixtes (800g)	 Blousons (800g)	 Jeans (800g)
 Drap de lit (600g)	 Vêtements de travail (1120g)	 Pyjamas (200g)
 Tricots de corps (180g)	 Sous-vêtements (70g)	 Chaussettes (50g)
 Draps housses (900g)	 Chemises (300g)	

AVANT LA PREMIÈRE UTILISATION

Afin d'éliminer les résidus qui pourraient avoir été produits en usine, essayez le tambour du sèche-linge avec un chiffon humide ou effectuez un bref séchage avec des chiffons humides placés dans le sèche-linge.







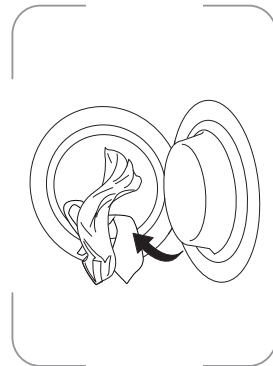

FONCTIONNEMENT DU SÈCHE-LINGE

- 1 Ouvrez la porte.**
- 2 Vérifiez si le filtre et le tambour sont propres.**
 - Si ce n'est pas le cas, nettoyez-les en vous référant au paragraphe "Nettoyage et entretien".
- 3 Placez le linge dans le tambour après l'avoir trié.**
 - Les vêtements doivent être triés en fonction de leur type de fibres et du niveau de séchage requis. Tous les cordons et ceintures des vêtements doivent être bien attachés et fixés avant d'être mis dans le tambour.
 - Ne surchargez pas le tambour (référez-vous au "Tableau des programmes" indiquant les recommandées pour chaque programme).



ATTENTION :

Ne faites pas sécher des vêtements non lavés dans le sèche-linge.

- 4 Refermez la porte.**
 - Avant de fermer la porte, vérifiez que le linge est bien inséré à l'intérieur du tambour, de sorte qu'il ne puisse pas se coincer ou être abîmé.
- 5 Appuyez sur  pour mettre le sèche-linge en marche.**
- 6 Sélectionnez un programme en tournant le bouton de sélection sur le programme souhaité.**
 - L'écran affichera le temps restant pour le programme que vous avez sélectionné.
 - Si vous sélectionnez l'un des programmes avec réglage de durée, (Air chaud , Air froid , Rafraîchissement ) réglez la durée de séchage en appuyant plusieurs fois sur .

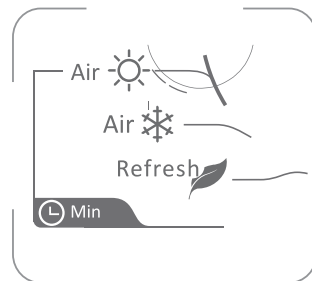

FR

NL

PT

EN

15







7 Sélectionnez la fonction anti-froissage si nécessaire.



Vous pouvez utiliser cette fonction pour empêcher le linge de se froisser si vous ne retirez pas le linge une fois le programme terminé. À la fin du cycle de séchage, la durée de la fonction anti-plis par défaut est de 30 minutes.

Vous pouvez appuyer sur  pour sélectionner 30, 60, 90 ou 120 minutes.

Cette fonction n'est pas disponible pour les programmes Air , Refresh  et .

8 Vous pouvez activer la fonction d'intensité de séchage requis en appuyant sur Intens. / .

Le temps de séchage augmentera de 10 minutes. Le témoin lumineux  s'allume.

Pour désactiver cette fonction, appuyez à nouveau sur  Intens. /  et le voyant  s'éteindra.

 **REMARQUE :** Cette fonction peut être sélectionnée avec les programmes illustrés ci-dessous.

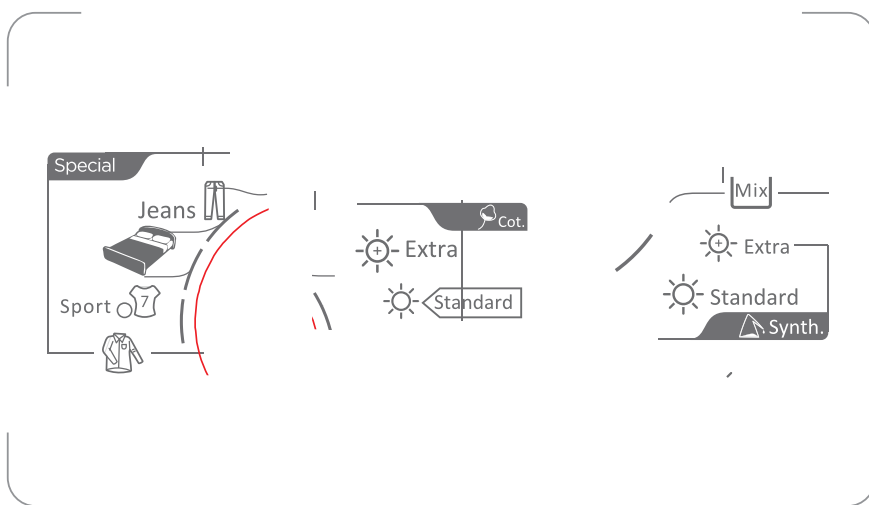

9 Appuyez sur .

10 Lorsque le cycle est terminé, le sèche-linge bipera si la fonction d'alerte. "End" s'affichera.





11 Ouvrez la porte et enlevez le linge.



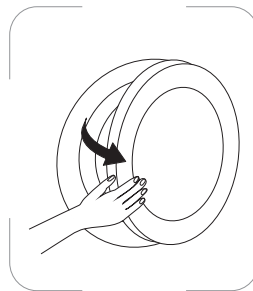

Attention ! L'intérieur du tambour peut encore être chaud.

Vérifiez que tous les articles ont été retirés du tambour. Si vous laissez des articles dans le sèche-linge, ceux-ci risquent d'être endommagés par un cycle de séchage supplémentaire lorsque le sèche-linge sera à nouveau utilisé.



12 Nettoyez le filtre comme décrit dans le paragraphe "Nettoyage et entretien".



















- Pour éviter les odeurs désagréables et pour mieux entretenir le joint de porte, gardez la porte du sèche-linge entrouverte jusqu'au prochain cycle de séchage.
- Les voyants  et  s'allument pour vous rappeler de nettoyer le filtre et de vider le réservoir d'eau de condensation.

13 Débranchez le câble d'alimentation de la prise murale lorsque l'appareil ne sera pas utilisé durant une longue période.



Tableau des programmes

Pour savoir quelle quantité de linge vous pouvez charger en fonction du programme sélectionné, veuillez vous référer aux recommandations ci-dessous. Les valeurs dans le tableau ci-dessous sont fournies à titre d'information seulement.

Type de linge	Programme de séchage	Capacité (kg)	Durée de séchage (minutes)	Articles à sécher
 Cot. Coton	 Extra	8	220	Tissus en coton tels que les serviettes, les T-shirts, les sous-vêtements et le linge de maison.
	 Standard		200	
	 Prêt à repasser		180	
 Délicate	Délicate	1	85	Linge délicat qui convient au séchage ou linge qui est conseillé d'être lavé à la main à une température inférieure.
 Mélange	Mélange	3,5	110	Tissus synthétiques et coton non teints
 Synth. Synthétiques	 Extra	3,5	100	Tissus synthétiques tels que les chemises, les chemisiers et la lingerie
	 Standard		90	
 Laine	Laine	1	25	Tissus en laine
 Min Time	Air  Air chaud	–	10	Pour sécher de petites quantités de linge à l'air chaud de 10 minutes à 120 minutes par intervalles de 10 minutes
	Air  Air froid	–	10	Pour sécher de petites quantités de linge à l'air froid de 10 minutes à 30 minutes par intervalles de 10 minutes
	Refresh  Rafraîchissement	1	20	Pour rafraîchir les vêtements qui ont été conservés dans des environnements fermés pendant une longue période de minimum 20 minutes à maximum 150 minutes par étapes de 10 minutes
Special	Jeans 	4,0	190	Jeans et vêtements de loisirs
	Draps de lit 	4,0	170	Pour sécher le linge de lit ou d'autres textiles de grande taille
	Sport 	3,0	80	Vêtements de sport, tissus fins, polyester ne nécessitant pas de repassage
	Chemises 	1,0	80	Vêtements faciles d'entretien tels que les chemises et les blouses





Remarque !

-  Ce symbole signifie le programme d'essai d'efficacité énergétique «programme coton standard», qui est conforme à la norme EN 61121 applicable et qui convient le mieux pour sécher une charge de coton normale à la capacité de charge nominale.
- Tissus épais ou multicouches, par ex. le linge de lit, les jeans, etc. ne sont pas faciles à sécher. Il est recommandé de choisir le programme Cotton Extra.
- Comme le matériau inégal, les vêtements épais et multicouches ne sont pas faciles à sécher, il est préférable de choisir le programme de séchage approprié pour les sécher si certaines parties des vêtements sont encore humides après la fin du programme.

Départ différé

Le départ d'un cycle de séchage peut être différé jusqu'à un maximum de 24 heures. Pour activer la fonction de départ différé procédez comme suit :



1. Sélectionnez le programme désiré.
2. Chaque fois que vous appuyez sur  , le délai de départ différé sera augmenté de 1 heure (jusqu'à 24 heures au maximum).
 - Le délai sélectionné apparaîtra sur l'écran d'affichage.
3. Appuyez sur  pour confirmer.
4. Une fois le délai écoulé, le programme sélectionné démarrera.

Pour annuler le départ différé :

Si vous souhaitez annuler le départ différé et démarrer immédiatement le programme, éteignez le sèche-linge, puis remettez-le en marche.

Selection du programme favori

Vous pouvez enregistrer un programme favori fréquemment utilisé.

1. Tournez le bouton de sélection des programmes pour sélectionner un programme. Sélectionnez les fonctions d'option si nécessaire.
2. Appuyez et maintenez  pendant environ 3 secondes. Le programme et les options définies seront enregistrés.
3. Vous pouvez tourner le bouton de programme sur la position My Cycle  pour démarrer votre programme et vos options préférées.







Verrouillage securite-enfants

Vous pouvez utiliser cette fonction pour empêcher les enfants de jouer avec votre sèche-linge.

Le bouton de programme et tous les boutons sauf le bouton **I** sont désactivés lorsque la fonction de sécurité enfant est active.

Pour activer cette fonction, maintenez enfoncés les boutons  et  simultanément pendant environ 3 secondes. Le voyant de verrouillage enfant  s'allume.

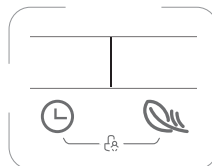

Pour désactiver cette fonction, maintenez ce bouton enfoncé de nouveau pendant environ 3 secondes.

Le témoin lumineux de verrouillage enfant s'éteint.





NETTOYAGE ET ENTRETIEN



Éteignez toujours l'appareil et débranchez-le toujours de la prise secteur avant toute procédure de nettoyage ou d'entretien.
N'utilisez jamais de nettoyant chimique ou abrasif.

Nettoyage externe

Essuyez régulièrement l'extérieur de la machine avec un chiffon légèrement humide. Puis séchez-le complètement.

Nettoyage de la surface intérieure de la porte

Nettoyez toujours la surface intérieure de la porte après chaque processus de séchage.
Essuyez la partie intérieure de la porte et du joint de porte avec un chiffon doux et humide pour éliminer les peluches.



Nettoyage du filtre à peluches

Le filtre collecte les peluches qui s'accumulent pendant le séchage et doivent être enlevées et le filtre nettoyé après chaque processus de séchage.
L'indicateur lumineux d'avertissement  s'allume pour vous rappeler de nettoyer le filtre à peluches.

1. Tirez le filtre à peluches vers le haut et en l'éloignant de l'appareil.
2. Ouvrez le filtre à peluches et retirez tous les fils ou peluches à la main ou avec une brosse nettoyez-le sous l'eau courante.

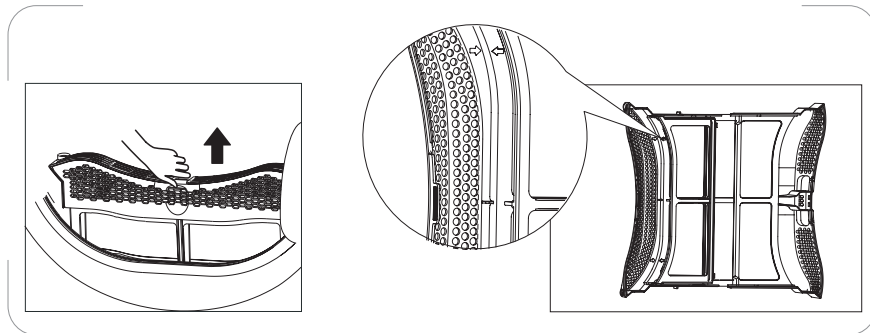

3. Fermez le filtre à peluches et remettez-le en place.

FR

NL

PT

EN

21





Vidange du réservoir d'eau

Videz le réservoir d'eau après chaque processus de séchage. Pour vider le réservoir d'eau :

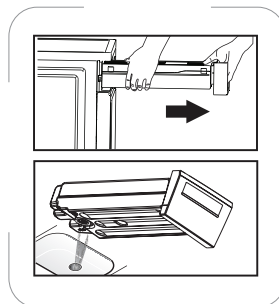

1. Tirez le réservoir d'eau et retirez-le soigneusement.
2. Videz l'eau du réservoir.
3. Remettez le réservoir d'eau en place.



L'eau condensée n'est pas potable !



Ne retirez jamais le réservoir d'eau lorsque l'appareil fonctionne !

Si vous oubliez de vider le réservoir d'eau, l'appareil s'arrêtera pendant le séchage lorsque le réservoir d'eau est plein et l'indicateur lumineux d'avertissement  s'allumera. Dans ce cas, vidangez le réservoir d'eau et appuyez sur  pour reprendre le cycle de séchage.

Nettoyage du dispositif de filtrage

Nettoyez le dispositif de filtrage après chaque processus de séchage.

1. Si un processus de séchage a été effectué, ouvrez le couvercle du dispositif de filtrage et attendez qu'il refroidisse.
2. Déverrouillez les 3 verrous du dispositif de filtrage. Retirez le dispositif de filtrage.
3. Nettoyez le dispositif de filtrage en le passant sous l'eau courante. Puis séchez-le complètement.

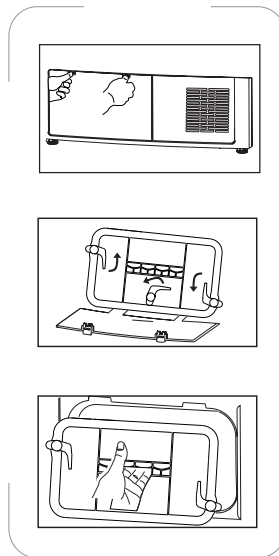



4. Si nécessaire, nettoyez l'échangeur de chaleur une fois tous les 2 mois.



Ne touchez pas l'échangeur de chaleur avec les mains !

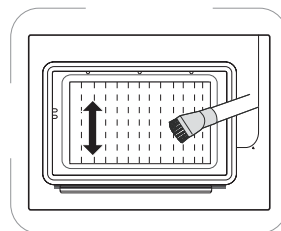



Retirez les peluches de l'échangeur de chaleur à l'aide d'un aspirateur équipé d'une brosse à poussière fixée. Nettoyez l'échangeur de chaleur sans appliquer de pression.

5. Remettez le dispositif de filtrage en place. Fixez les 3 verrous et assurez-vous qu'ils sont bien fixés.
6. Fermez le couvercle jusqu'à ce qu'un déclic se fasse entendre.





GUIDE DE DÉPANNAGE

Problèmes	Solutions possibles
Le sèche-linge ne démarre pas.	Contrôlez la porte et vérifiez qu'elle est correctement fermée.
	Vérifiez que le programme est défini.
	Vérifiez que le bouton de démarrage  a été pressé.
L'affichage n'est pas allumé.	Vérifiez si l'alimentation électrique est activée.
	Vérifiez si la fiche électrique est insérée.
	Vérifiez si un programme est défini.
	Vérifiez si le bouton d'alimentation  a été pressé.
Le degré de séchage n'est pas atteint.	Nettoyez le filtre à peluches et l'échangeur de chaleur.
	La cuve est vide.
	Inspectez le tuyau de vidange.
	L'endroit d'installation du sèche-linge est trop restreint.
	Utilisez un programme de niveau de séchage plus élevé.

 Si vous ne pouvez pas résoudre vous-même les problèmes et avez besoin d'aide,

- appuyez sur  pour éteindre l'appareil et débranchez-le.
- contactez le service après-vente.

Codes d'erreur

Affichage	Cause	Solution
E32	Erreur du capteur d'humidité	Veuillez contacter le service après-vente local si l'erreur se produit.
E33	Erreur du capteur de température	
E82	Erreur de communication	





FICHE PRODUIT

La fiche produit de ce sèche-linge est conforme à la directive européenne N° 392/2012.

Marque	Proline	
Modèle	PROHP82	
Capacité nominale du linge en coton pour le programme « coton standard » à pleine charge	8 kg	
Type de séchage	Condensateur	
Classe d'efficacité énergétique ¹	A++	
Consommation d'énergie annuelle pondérée (AEC) ²	235 kWh/annum	
Procédé de séchage	Sèche-linge automatique	
Consommation d'énergie du programme coton standard	à pleine charge (Eséchage)	1,78 kWh
	à charge partielle (Eséchage1/2)	1,01 kWh
Consommation d'énergie du programme coton standard à pleine charge	mode d'arrêt (Po)	0,43 W
	mode de veille (PI)	0,52 W
Durée du mode de veille	10 minutes	
Programme de séchage standard ³		
Durée du programme pondérée (Tt) du programme « coton standard à pleine charge et à charge partielle »	143 minutes	
Durée du programme « coton standard »	à pleine charge (Tséchage)	210 minutes
	à charge partielle (Tséchage1/2)	110 minutes
Classe d'efficacité de condensation ⁴	B	
Efficacité de la condensation moyenne du programme coton standard	à pleine charge (Cséchage)	84 %
	à charge partielle (Cséchage1/2)	84 %
Efficacité de condensation pondérée (Ct) pour le programme « coton standard » à pleine charge et charge partielle	84 %	
Niveau de puissance acoustique (valeur moyenne pondérée -LWA) pour le programme coton standard à pleine charge	65 dB	
Appareil intégré O/N	Non	

- ¹ De A+++ (le plus efficace) à D (le moins efficace)
- ² Consommation d'énergie annuelle 235 kWh, basée sur 160 cycles de séchage du programme « coton standard » à pleine charge et à demi-charge et la consommation des modes à faible puissance. La consommation réelle d'énergie par cycle dépend des conditions d'utilisation de l'appareil.

FR

NL

PT

EN

25





- ③ Le « programme coton standard » utilisé à pleine charge et à demi-charge est le programme de séchage standard auquel se rapportent les informations qui figurent sur l'étiquette et sur la fiche. Ce programme convient pour le séchage de textiles en coton normalement humides et il constitue le plus efficace en terme de consommation d'énergie pour le coton.
- ④ De A(le plus efficace) à G (le moins efficace)



SPÉCIFICATIONS

Tension/fréquence nominale	220-240V~ 50Hz
Puissance nominale	800W
Degré d'étanchéité	IPX4
Réfrigérant	R290 / 120 g PRP: 3 CO2 - eq: 0T

Fermé hermétiquement





MISE AU REBUT



En tant que distributeur responsable, nous accordons une grande importance à la protection de l'environnement.

Nous vous encourageons à respecter les procédures correctes de mise au rebut de votre appareil, des piles et des éléments d'emballage. Cela aidera à préserver les ressources naturelles et à garantir qu'il soit recyclé d'une manière respectueuse de la santé et de l'environnement.

Vous devez jeter ce produit et son emballage selon les lois et les règles locales. Puisque ce produit contient des composants électroniques et parfois des piles, le produit et ses accessoires doivent être jetés séparément des déchets domestiques lorsque le produit est en fin de vie.

Pour plus de renseignements sur les procédures de mise au rebut et de recyclage, contactez les autorités de votre commune.

Apportez l'appareil à un point de collecte local pour qu'il soit recyclé. Certains centres acceptent les produits gratuitement.

Hotline Darty France

Quels que soient votre panne et le lieu d'achat de votre produit en France, avant de vous déplacer en magasin Darty, appelez le 0 978 970 970 (prix d'un appel local) 7j/7 et 24h/24.

Hotline Vanden Borre

Le service après-vente est joignable au +32 2 334 00 00, du lundi au samedi de 8h à 18h.

Hotline Fnac France

Quels que soient votre panne et le lieu d'achat de votre produit en France, avant de vous déplacer en magasin Fnac, appelez le 0 969 324 334 du lundi au samedi (8h30-21h00) et le dimanche et jours fériés (10h00-18h00), (prix d'un appel local)

FR

NL

PT

EN

27



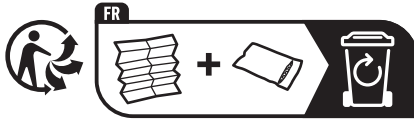















En raison des mises au point et améliorations constamment apportées à nos produits, de petites incohérences peuvent apparaître dans ces instructions. Veuillez nous excuser pour la gêne occasionnée.

Etablissements Darty & fils ©,
9 Rue des Bateaux-Lavois, 94200 Ivry-sur-Seine, France 31/01/2024





INHOUDSOPGAVE

	BELANGRIJKE VEILIGHEIDSINSTRUCTIES.....	30
	ENERGIEBESPARINGSTIPS.....	33
	HET APPARAAT UITPAKKEN.....	33
	PRODUCTBESCHRIJVING.....	34
	VOOR INSTALLATIE VAN HET APPARAAT.....	36
	INSTALLATIE.....	36
	ELEKTRISCHE AANSLUITING.....	39
	OPMERKINGEN OVER HET WASSEN.....	40
	VOORINGEBRUIKNAME.....	41
	DE DROOGTROMMEL GEBRUIKEN.....	42
	REINIGING EN ONDERHOUD.....	48
	PROBLEEMOPLOSSING.....	51
	PRODUCTFICHE.....	52
	SPECIFICATIES.....	53
	VERWIJDERING.....	54





BELANGRIJKE VEILIGHEIDSINSTRUCTIES

LEES DE VOLGENDE VEILIGHEIDSINSTRUCTIES AANDACHTIG DOOR VOORDAT U HET APPARAAT IN GEBRUIK NEEMT EN BEWAAR ZE VOOR TOEKOMSTIG GEBRUIK.

Waarschuwingen

-  Lees de instructies.
- Dit apparaat is geschikt voor huishoudelijk gebruik en gelijksoortige toepassingen zoals:
 - kantines voor personeel in winkels, kantoren en andere werkomgevingen;
 - boerderijen;
 - door gasten in hotels, motels en andere woonomgevingen;
 - bed & breakfasts.
- Laat het snoer vervangen door de fabrikant, servicedienst of gelijksoortig bevoegd person als deze beschadigd is om risico's te voorkomen.
- Dit apparaat mag worden gebruikt door kinderen vanaf 8 jaar oud en personen met beperkte fysieke, visuele of mentale mogelijkheden, of die een gebrek aan ervaring en kennis hebben indien ze gepaste instructies hebben gekregen zodat ze het apparaat op een veilige manier kunnen gebruiken en op de hoogte zijn van de gevaren die het gebruik van het apparaat met zich meebrengt.
Laat kinderen niet met het apparaat spelen.
Kinderen mogen het apparaat niet zonder toezicht reinigen of onderhouden.
- Het maximum gewicht aan droog textile dat in het apparaat mag worden gebracht is 8 kg.
- Voor details over de reinigingsmethode, zie de rubriek "REINIGING EN ONDERHOUD" op pagina's 48 -50.
- Voor verwijdering van het apparaat :**
Om mogelijke schade aan het milieu of de menselijke gezondheid door ongecontroleerde afvalverwijdering te voorkomen, moet u het op een verantwoorde manier recyclen om duurzaam





hergebruik van materiële hulpbronnen te bevorderen. En de verwijdering mag alleen gebeuren via openbare inzamelpunten.

- **Voor installatie, onderhoud :**

Het apparaat moet op een horizontale vloer worden geplaatst en de ventilatie vrij houden. Probeer geen componenten zelf te vervangen of te repareren, vraag indien nodig het servicebureau om hulp.

- **Voor behandeling :**

Behandel het apparaat altijd om schade te voorkomen.

- De droogtrommel mag niet worden gebruikt al ser industriële chemicaliën gebruikt warden om schoon te maken.
- Maak de pluisfilter regelmatig schoon.
- Vermijd ophoping van pluis in de droogtrommel.
- Er moet voldoende ventilatie zijn om het terugstromen van gassen in de kamer te voorkomen voor apparaten die andere gassen branden, waaronder open vuur.
- Droog geen ongewassen artikelen in de droogtrommel.
- Items die zijn bevuild met stoffen zoals spijsolie, aceton, alcohol, benzine, petroleum, vlekkenverwijderaars, terpentijn, was en wasverwijderaars moeten eerst in warm water met een extra hoeveelheid wasmiddel worden gewassen voordat ze in de droogtrommel gedroogd mogen worden.
- Items zoals schuimrubber (latexschuim), douchekapjes, waterdicht textile, artikelen met een rubber achterkant en kleding of kussens met schuimrubber mogen niet in de droogtrommel worden gedroogd.
- Wasverzachters of soortgelijke producten moeten worden gebruikt zoals aangegeven in de wasverzachterinstructies.
- Haal alle voorwerpen, zoals aanstekers en lucifers, uit de zakken.
- **WAARSCHUWING:** Stop een droogtrommel nooit voor het einde van de droogcyclus, tenzij alle items snel verwijderd en verspreid worden zodat de warmte kan ontsnappen.
- **WAARSCHUWING:** het apparaat mag niet van stroom worden

FR

NL

PT

EN

31



voorzien via een extern schakelapparaat, zoals een timer, of worden aangesloten op een stroomkring die door en nutsbedrijf regelmatig wordt in-en uitgeschakeld.

- Houd kinderen jonger dan 3 jaar altijd uit de buurt of houd er continu toezicht op.
- Een tapijt mag de openingen niet verhinderen.
- Uitlatlucht dient niet afgevoerd te worden in een rookkanaal dat gebruikt wordt om gassen af te voeren van apparaten die gas of andere brandstoffen branden.
- Installeer dit apparaat niet achter een vergrendelbare deur, een deur met scharnieren aan de tegenovergestelde kant van de droogtrommel, het volledig openen van de droogtrommel kan hierdoor worden belet.
- De stekker moet na installatie van het apparaat goed bereikbaar blijven.



De oppervlakken kunnen tijdens gebruik heet worden.



- **WAARSCHUWING:** Brandgevaar / Ontvlambare materialen
- **WAARSCHUWING:** Houd de ventilatieopeningen in de behuizing van het apparaat of in de ingebouwde structuur vrij van verstoppingen.
- **WAARSCHUWING:** Beschadig het koelcircuit niet.

Veiligheidsmaatregelen

- Niet voor gebruik buitenshuis.
- Raak het apparaat niet aan wanneer handen of voeten vochtig of nat zijn.
- Leun niet op de deur bij het laden van de machine en gebruik de deur niet om de machine op te tillen of te verplaatsen.
- Gebruik het apparaat niet als het pluizenfilter niet op zijn plaats zit of beschadigd is.
- Trek altijd de stekker uit het stopcontact voordat u het apparaat reinigt.
- Blijf dit apparaat niet gebruiken als het defecten vertoont.





ENERGIEBESPARINGSTIPS

Om onnodig lange droogtijden en een hoog energieverbruik te voorkomen:

- Zorg dat uw wasgoed grondig is gecentrifugeerd voordat u het droogt.
- Laad het apparaat volgens de ideale hoeveelheid wasgoed die voor het gebruikte programma is aanbevolen (Zie Programmatafel).
- Zorg dat de ruimte waar de droogtrommel zich in bevindt goed wordt gelucht.
- Zorg dat de filter voor gebruik van de droogtrommel droog is.

HET APPARAAT UITPAKKEN

- Dit apparaat is zwaar. Wees voorzichtig wanneer u het verplaatst.
- Tijdens het uitpakken van het apparaat, controleer op eventuele schade. In geval van twijfel, gebruik het apparaat niet en neem contact op met het servicecentrum.
- Verwijder alle verpakking voor gebruik.

FR

NL

PT

EN

33



PRODUCTBESCHRIJVING

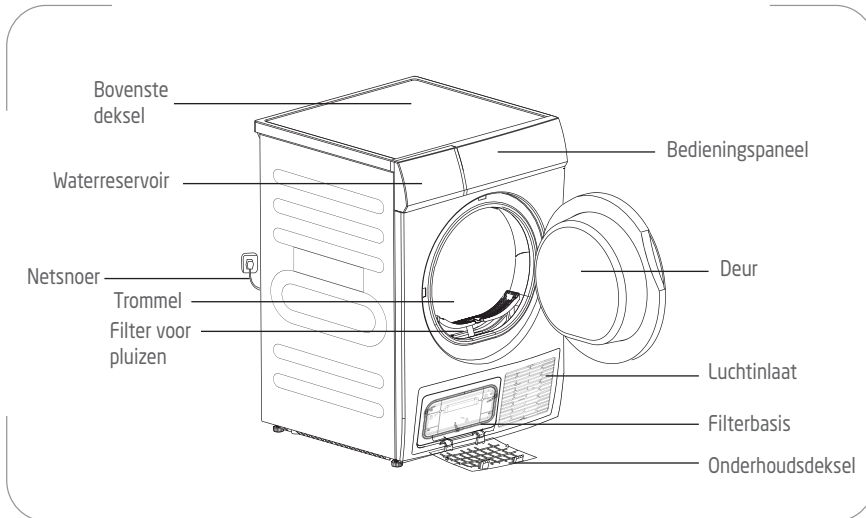

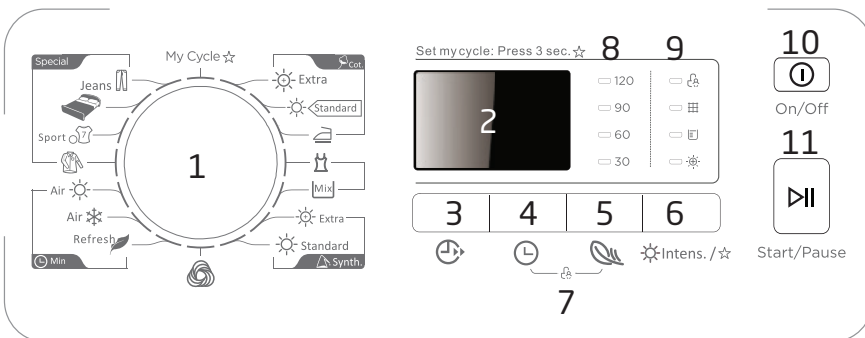

Bedieningspaneel









1. Knop voor programmakeuze
2. Display
Dit display wordt gebruikt voor het weergeven van de instellingen
88:88 / 88 Geschatte resterende droogtijd /Foutcodes
04 Vertaagde start
3. Uitgestelde start knop





4.  Tijd knop
5.  Anti-kreuk knop
6.  Intens. /  Droogintensiteit / Favoriete programma knop
7.   Kinderslot knops
8. Indicatielampjes voor anti-kreuktijd
9. Indicatie lichten

			
Kinderslot	Filter reinigen	Waterreservoir ledigen	Droogniveau

10.  Aan/Uit-knop
11.  Start/Pauze-knop





VOOR INSTALLATIE VAN HET APPARAAT

Controleer voordat u uw droogtrommel op de netvoeding aansluit of de spanning op het typeplaatje van uw apparaat overeenstemt met de spanning bij u thuis. Een andere spanning kan het apparaat beschadigen.

De stekker is de enige manier om het apparaat van de voeding te ontkoppelen, zorg dat deze altijd makkelijk bereikbaar is. Om de voeding naar het apparaat te ontkoppelen, schakel het apparaat uit en haal vervolgens de stekker uit het stopcontact.

Het apparaat moet geaard zijn. De fabrikant is niet verantwoordelijk voor schade die ontstaat door het niet gebruiken van een aarding.

INSTALLATIE

- Voor uw gemak is het aanbevolen om het apparaat in de buurt van uw wasmachine te plaatsen.
- Installeer het apparaat in een schone ruimte, waar vuil niet wordt opgehoopt.
- Plaats het apparaat niet in de buurt van een gasfornuis, kooktoestel, verwarmingstoestel of grill, de vlammen van de branders kunnen schade veroorzaken.
- Tijdens de installatie van het apparaat, zorg dat het snoer niet gekneld of gedraaid is.
- Om de trilling en het lawaai tot een minimum te beperken wanneer de droogtrommel in werking is, plaats het op een stevig en vlak oppervlak.

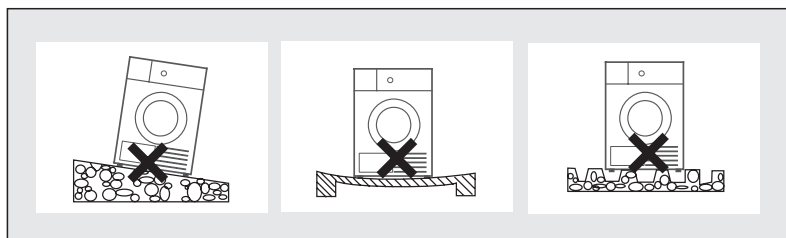



Het apparaat nivelleren

Zorg dat de droogtrommel perfect vlak staat voor een veilige en juiste werking. Als de droogtrommel niet perfect vlak staat, pas de stelvoetjes aan zoals vereist. Plaats GEEN houten blokjes of ander voorwerp onder de voetjes.

- ⚠ Als het apparaat op vloerbekleding wordt geplaatst, pas de voetjes aan zodat er lucht onder het apparaat kan circuleren.
- ⚠ Haal de voetjes niet af. Belemmer de ruimte tot de vloer niet door het apparaat op hoogpolige vloerkleden, houten blokjes of gelijksoortig te plaatsen. Dit kan de warmte doen toenemen en de werking van het apparaat negatief beïnvloeden.

Stel het apparaat waterpas door de voetjes omhoog of omlaag te brengen. Plaats nooit karton, houten blokken of gelijksoortig materiaal onder de machine om deze waterpas te zetten.

De machine volledig waterpas zetten voorkomt trilling, lawaai en verschuiving van het apparaat tijdens de werking.

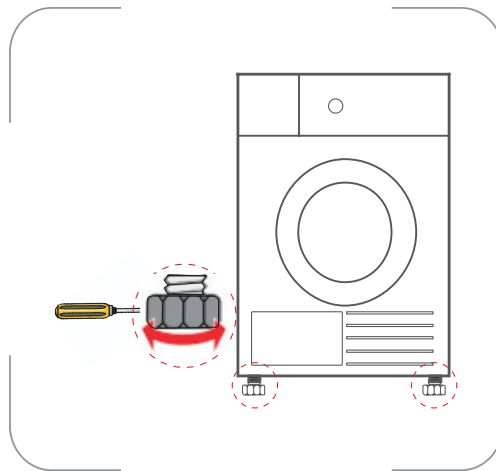

FR

NL

PT

EN

37





Installeren van accessoires

Als u de volgende onderdelen heeft, draag dan handschoenen en installeer deze volgens onderstaande instructies.

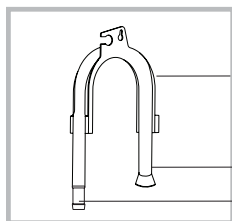

Slanghouder

Afvoerslang

Stekker

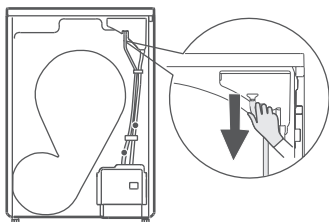

Trek de bovenste afvoerslang omhoog.

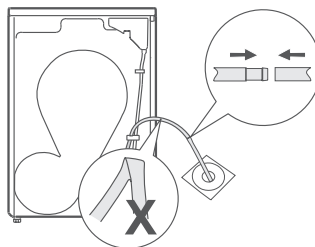

Stop de externe afvoerslang in de vloerafvoer.
(Zorg dat de externe afvoerslang niet wordt gebogen.)





ELEKTRISCHE AANSLUITING

Gevaar:

Om de elektrische aansluiting naar uw apparaat te maken:

- De installatie naar de netvoeding dient in overeenstemming te zijn met de lokale richtlijnen en voorschriften.
- Gebruik geen verlengsnoer, een adapterstekker, etc.
- De stekker moet na het installeren van het apparaat eenvoudig bereikbaar zijn.
- In geval van twijfel over de toestand van uw aansluiting, raadpleeg een bekwame elektricien.



Waarschuwing! De fabrikant is niet aansprakelijk voor schade of letsel veroorzaakt door het negeren van bovenstaande waarschuwingen over de elektrische aansluiting.



FR

NL

PT

EN

39







OPMERKINGEN OVER HET WASSEN

Waslabels

Kledingstukken hebben hun eigen waslabels. Drogen in overeenstemming met onderstaande waslabels is aldus aanbevolen.

			
Droog	Machinaal drogen	Niet in droogtrommel drogen	Niet drogen
			
Aan de waslijn / handgend drogen	Druipdroog	Vlak laten drogen	In de schaduw
			
Chemisch reinigen	Niet chemisch reinigen	Chemisch reinigen, alle oplosmiddelen	Chemisch reinigen, alleen aardolie

Nieuwe, donker gekleurde kledingstukken moeten afzonderlijk van licht gekleurde kledingstukken gewassen en gedroogd worden om het Mengten van kleuren of verkleuring van kledingstukken of zelfs de kunststof onderdelen in de droogtrommel te voorkomen. Donker gekleurde vezels kunnen tevens op licht gekleurde kledingstukken en vice versa terecht komen.

Rubber en kunststof

Droog geen items van of die rubber of kunststof bevatten, zoals:

- schorten, slabbetjes en stoelovertrekken
- gordijnen en tafelkleden
- badmatten

Babykleding en nachthemden

Controleer altijd de waslabels van de fabrikant.





Kreukvrije kledingstukken

Verwijder kreukvrije kledingstukken zodra de droogtrommel stopt om kreuken te beperken.

Lusvorm geweven kledingstukken

Bepaalde lusvorm geweven kledingstukken, zoals T-shirts en ondergoed, hebben de neiging om te krimpen, afhankelijk van de kwaliteit. Droog deze kledingstukken niet te veel.

Laadvermogen

De volgende gewichten dienen uitsluitend ter referentie.

 Jassen uit meerdere materialen (800g)	 Vesten (800g)	 Jeans (800g)
 beddenlaken (600g)	 Werkkleding (1120g)	 Pyjama (200g)
 Onderhemden (180g)	 Onderbroeken (70g)	 Sokken (50g)
 Handdoek (900g)	 Hemden (300g)	

VOOR INGEBRUIKNAME

Om eventuele fabricageresten te verwijderen, veeg de trommel schoon met een vochtige doek of voer een korte droogcyclus met vochtige doeken in de droogtrommel uit.

FR

NL

PT

EN

41





DE DROOGTROMMEL GEBRUIKEN

1 Open de deur.

2 Controleer of de filter en trommel schoon zijn.

- Als dit niet het geval is, reinig deze zoals vermeld in de sectie 'Reiniging en onderhoud'.

3 Plaats het wasgoed losjes in de trommel na het sorteren.

- Sorteert de kledingstukken volgens het type vezel en het nodig droogniveau. Alle koorden en riemen van kledingstukken moeten goed vastegemaakt zijn voordat u ze in de trommel doet.
- Overbelast de trommel niet (zie de "Programmatabel" voor de aanbevolen lading voor elk programma).

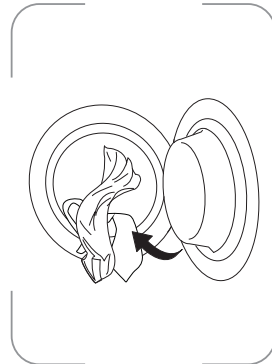

OPGELET:





Droog geen ongewassen kledingstukken in de droogtrommel.

4 Sluit de deur.

- Voordat u de deur sluit, controleer of het wasgoed zich volledig en goed in de trommel bevindt zodat het niet vast komt te zitten of beschadigd raakt.

5 Druk op **i** om de droogtrommel in te schakelen.

6 Selecteer een programma door de programmakeuzeknop naar de gewenste positie te draaien.

- Het display heeft de resterende tijd weer voor het programma dat u hebt gekozen.
- Als u een van de tijdprogramma's selecteert, (Warme lucht Air , Koude lucht Air , Opfrissen Refresh ) kunt u de droogtijd instellen door herhaaldelijk op  te drukken.

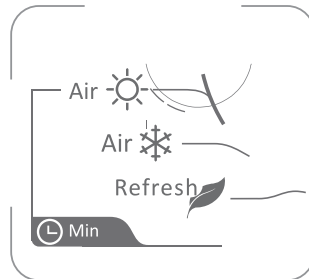



7 Indien nodig, selecteer de anti-kreukfunctie.

U kunt deze functie gebruiken om te voorkomen dat het wasgoed kreukt als u het wasgoed niet uit de machine haalt nadat het programma is afgelopen. Aan het einde van de droogcyclus is de standard antikreuktijd 30 minuten.



U kunt op  drukken om 30, 60, 90 of 120 minuten te selecteren.

Deze functie is niet beschikbaar voor de Air , Refresh  en  programma's.

8 U kunt de functie voor droogintensiteit activeren op te drukken

 Intens. / ☆ .

De droogtijd wordt met 10 minuten verlengd. Het indicatielampje  gaat branden.

Om deze functie uit te schakelen, drukt u nogmaals op  Intens. / ☆ en het indicatielampje  gaat uit.

 **OPMERKING:** Deze functie kan worden geselecteerd met de onderstaande programma's.

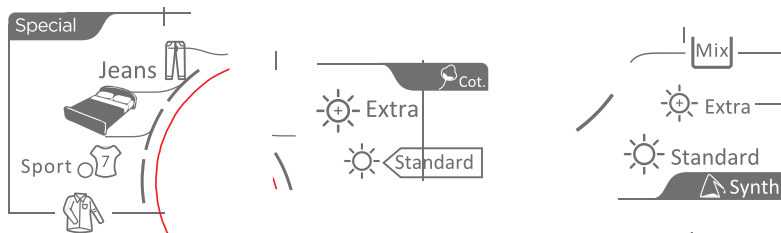

9 Druk op .

10 Na het beëindigen van de cyclus kunt u pieptonen horen het display geeft "End".

FR

NL

PT

EN

43





11 Open de deur en haal het wasgoed uit.



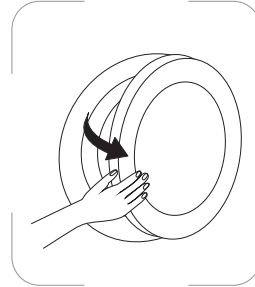

Voorzichtig ! De binnenkant van de trommel kan nog warm zijn.

Controleer of alle items uit de trommel zijn gehaald. Als er zich nog items in de droogtrommel bevinden, kunnen deze tijdens de volgende droogcyclus door overmatig drogen beschadigd raken.



12 Reinig de filter zoals beschreven in het hoofdstuk Reiniging en Onderhoud.

- Om onaangename geuren te voorkomen en een goede staat van de deurafdichting te handhaven, houd de deur van het apparaat lichtjes open tot de volgende droogcyclus.
- De indicatielampjes  en  gaan branden om u eraan te herinneren de filter te reinigen en het condenswaterreservoir te ledigen.



















13 Haal de stekker uit het stopcontact als u het apparaat gedurende een lange periode niet zult gebruiken.





Programmatabel

Volg de aanbevolen lading met wasgoed wanneer u een bepaald programma gebruikt. De waarden, die in onderstaande tabel zijn vermeld, zijn louter informatief.

Type wasgoed	Droog-programma	Capaciteit (kg)	Droogtijd (minuten)	Voor het drogen van
 Cot. Katoen	 Extra	8	220	Katoenen stiften zoals handdoeken, T-shirts, ondergoed en beddegoed
	 Standard		200	
	 Strijken		180	
 Delicaat	Delicaat	1	85	Fijn wasgoed dat geschikt is om te drogen of wasgoed dat met de hand moet worden gewassen op een lagere temperatuur.
 Mix	Mix	3,5	110	Ongeverfde synthetische en katoenen stoffen
 Synth. Synthetisch	 Extra	3,5	100	Synthetische stiften zoals hemden, bloezen en lingerie
	 Standard		90	
 Wol	Wol	1	25	Wollen stoffen
 Min	 Air Warme lucht	–	10	Om kleine ladingen wasgoed met warme lucht tussen 10 en 120 miuten te drogen, in stappen van 10 minuten.
	 Air Koude lucht	–	10	Om kleine ladingen wasgoed met koude lucht tussen 10 en 30 miuten te drogen, in stappen van 10 minuten.
	 Refresh Oprissen	1	20	Voor het oprissen van kleding die lange tijd in gesloten omgevingen is bewaard van minimaal 20 minuten tot maximaal 150 minuten in stappen van 10 minuten
Special	 Jeans	4,0	190	Jeans en vrijetijdskleding
	 Beddegoed	4,0	170	Om beddegoed of ander groot textiel te drogen
	 Sport	3,0	80	Sportkleding, dunne stiften, polyester die niet mogen gestreken worden
	 Hemden	1,0	80	Onderhoudsvriendelijke kleding zoals overhemden en blouses

FR

NL

PT

EN

45





Opmerking!

-  Dit symbool betekent het energie-efficiëntie-testprogramma "standaard katoenprogramma", dat in overeenstemming is met de toepasselijke EN 61121-norm en het meest geschikt is om normale katoenlading bij nominaal laadvermogen te drogen.
- Dikke of meerlagige stoffen, b.v. beddengoed, jeans enz. zijn niet gemakkelijk te drogen. Het wordt aanbevolen om het programma Cotton Extra te kiezen
- Omdat het oneffen materiaal, dikke en meerlagige kleding niet gemakkelijk te drogen is, is het beter om het juiste tijddroogprogramma te kiezen om ze te drogen als sommige delen van de kleding na afloop van het programma nog vochtig zijn

Uitgestelde start

De droogcyclus kan tot 24 uur worden uitgesteld Om deze functie in te schakelen:



1. Selecteer het gewenste programma.
2. Druk herhaaldelijk op  om de uitsteltijd per 1 uur, tot 24 uur, te verhogen.
 - Het display geeft de uitsteltijd weer.
3. Druk op  om te bevestigen.
4. Het geselecteerde programma start eenmaal de uitsteltijd is verstreken.

Om de uitgestelde start te annuleren :

Als u de uitgestelde start wilt annuleren en het programma wilt starten, schakel de droogtrommel uit en vervolgens opnieuw aan.

Favoriete programmaselectie

U kunt een favoriete programma opslaan dat vaak wordt gebruikt.

1. Draai aan de programmaknop om het gewenste programma te selecteren. Selecteer de optie-functies indien nodig.
2. Houd de knop  Intens. /  ongeveer 3 seconden ingedrukt. Het ingestelde programma en de opties worden opgeslagen.
3. U kunt de programmaknop naar de positie My Cycle  draaien om uw favoriete programma en opties te starten.







Kinderslot

U kunt deze functie gebruiken om te voorkomen dat kinderen met uw droger spelen.

De programmaknop en alle knoppen behalve de knop  worden gedeactiveerd wanneer de het kinderslot actief is.

Om deze functie te activeren houdt U  en  tegelijkertijd ongeveer 3 seconden ingedrukt. Op het display verschijnt het kinderslotsymbool. Het kinderslot-indicatielampje  zal oplichten.

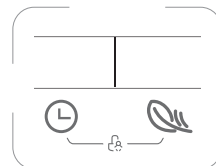

Om deze functie uit te schakelen, houdt u dezelfde knoppen opnieuw ongeveer 3 seconden ingedrukt. Het lampje van het kinderslot gaat uit.



FR

NL

PT

EN

47





REINIGING EN ONDERHOUD



Schakel het apparaat uit en haal de stekker uit het stopcontact voordat u het schoonmaakt.

Schakel het apparaat uit en haal de stekker uit het stopcont

Externe reiniging

Veeg de buitenkant van het apparaat af met een vochtige doek. Droog grondig af.

Reinigen van de binnenkant van de deur

Reinig na elk droogprogramma de binnenkant van de deur.

Veeg de binnenkant van de deur en het deurrubber af met een zachte vochtige doek om eventuele pluïsjes te verwijderen.



Reinigen van het pluïzenfilter

Het filter vangt pluïzen op die zich tijdens het drogen ophopen en moet na elk droogproces worden verwijderd en gereïnid.

Het waarschuïwingslampje  wordt weergegeven om u te herinneren aan het schoonmaken van het pluïzenfilter.

1. Trek het pluïzenfilter naar boven en uit het apparaat.
2. Open het pluïsfiter en verwijder draad of pluïsjes met de hand of met een zachte borstel. Maak het schoon onder stromend water.

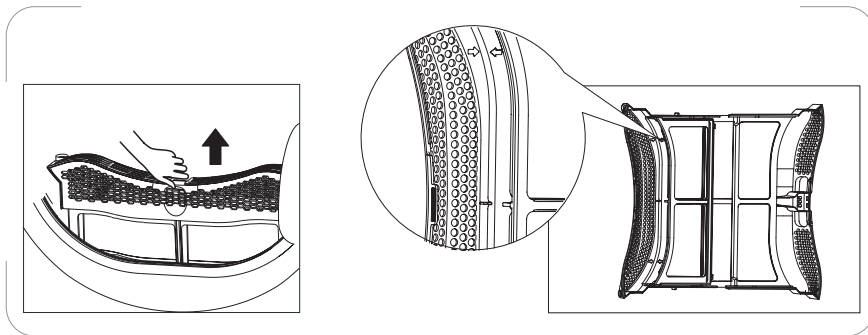

3. Siu it het pluïzenfilter en plaats het terug in de machine.





Legen van het waterreservoir

Laat het waterreservoir na elk droogproces leeglopen. Om het waterreservoir af te tappen:

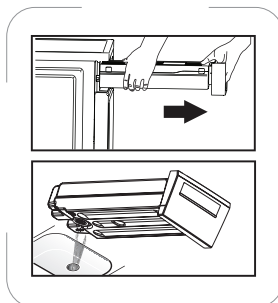

1. Trek aan het waterreservoir en verwijder het voorzichtig.
2. Laat het water in het reservoir weglopen.
3. Plaats het waterreservoir terug in de machine.



Het condenswater is geen drinkwater!



Verwijder nooit het waterreservoir als het apparaat in werking is!

Als u vergeet het waterreservoir af te tappen, stopt het apparaat tijdens het drogen als het waterreservoir vol is en brandt het waarschuwingslampje . In dit geval laat u het waterreservoir leeglopen en drukt u op  om de droogcyclus te hervatten.

Reinigen van de filterbasis

Reinig de filterbasis na elk droogproces.

1. Als er een droogproces is uitgevoerd, opent u het deksel van de filterbasis en wacht u tot deze is
2. Ontgrendelen van de 3 filtervergrendelingen. Trek de filterbasis eruit. Ontgrendelen van de 3 filtervergrendelingen. Trek de filterbasis eruit.
3. Reinig de filterbasis onder stromend water. Droog grondig af.

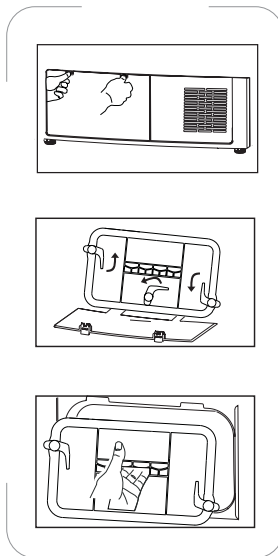

FR

NL

PT

EN

49



4. Maak de warmtewisselaar indien nodig één keer per 2 maanden schoon.



Raak de warmtewisselaar niet aan met uw handen!

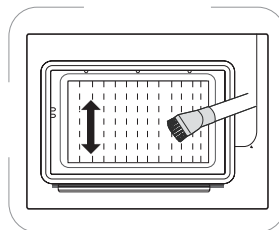



Verwijder de pluisjes van de warmtewisselaar met behulp van een stofzuiger met daarop een afstofborstel. Reinig de warmtewisselaar zonder druk uit te oefenen.

5. Plaats de filterbasis terug in de machine. Maak de 3 vergrendelingen vast en zorg ervoor dat ze goed vastzitten.
6. Sluit het deksel tot u een klik hoort.





PROBLEEMOPLOSSING

Problemen	Mogelijke oplossing
Drager start niet.	Controleer of de deur goed gesloten is.
	Controleer of het programma is ingesteld.
	Controleer of de startknop  is ingedrukt.
Display staat niet aan.	Controleer of de stroomvoorziening in orde is.
	Controleer of de stekker in het stopcontact zit.
	Controleer of het programma is ingesteld.
	Check the power button  is ingedrukt.
De mate van droogte wordt niet bereikt.	Reinig het pluizenfilter en de warmtewisselaar.
	Leeg het waterreservoir.
	Controleer de afvoeslang.
	De installatieplaats van de droger is te beperkt.
	Gebruik een programma met een hoger droogniveau.



Als u problemen niet zelf kunt oplossen en hulp nodig hebt,

- druk dan op  om het apparaat uit te schakelen en trek de stekker uit het stopcontact.
- neem contact op met de servicedienst.

Foutcodes

Display	Oorzaak	Oplossing
E32	Fout in de vochtigheidssensor	Neem contact op met uw servicedienst als deze fout optreedt.
E33	Fout in de temperatuursensor	
E82	Fout in de communicatie	

FR

NL

PT

EN

51



PRODUCTFICHE

De productfiche van deze droogtrommel is opgesteld in overeenstemming met EU-verordening nr. 392/2012.

Merk	Proline	
Model	PROHP82	
Nominale capaciteit voor het standaard katoenprogramma bij volledige belading	8 kg	
Drogertype	Condensdroger	
Energie-efficiëntieklasse ①	A++	
Gewogen jaarlijks energieverbruik (AEc) ②	235 kWh/annum	
Droogproces	Automatische droger	
Energieverbruik van het standaard katoenprogramma	bij volle lading (Edry)	1,78 kWh
	bij gedeeltelijke lading (Edry1/2)	1,01 kWh
Energieverbruik bij het standaard katoenprogramma bij volledige belading	uit-stand (Po)	0,43 W
	stand-by-modus (PI)	0,52 W
Duur van de stand-by-stand	10 minuten	
Standaard droogprogramma ③		
Gewogen programmatijd (Tt) van het standaard katoenprogramma bij volledige en gedeeltelijke belading	143 minuten	
Programmatijd van het standaard katoenprogramma	bij volle lading (Tdry)	210 minuten
	bij gedeeltelijke lading (Tdry1/2)	110 minuten
Condensatie-efficiëntieklasse ④	B	
Gemiddelde condensatie efficiëntie van het standaard katoenprogramma	bij volle lading (Cdry)	84 %
	bij gedeeltelijke lading (Cdry1/2)	84 %
Gewogen condensatie-efficiëntie (Ct) voor de norm katoenprogramma bij volledige en gedeeltelijke belading	84 %	
Geluidsniveau (gewogen gemiddelde waarde -LWA) voor het standaard katoenprogramma bij volle belading	65 dB	
Inbouwapparaat J/N	Nee	

- ① Van A+++ (meest efficiënt) tot D (minst efficiënt)
- ② Energieverbruik 235 kWh per jaar, gebaseerd op 160 standaard droogcycli van het standaard katoenprogramma bij volle en gedeeltelijke lading en verbruik op lage vermogenmodi. Het werkelijk energieverbruik per cyclus is afhankelijk van de gebruikswijze van het apparaat.





- ③ Het 'standaard katoenprogramma', dat bij volle en gedeeltelijke lading wordt gebruikt, is het standaard droogprogramma waar de informatie op het etiket en de fiche naar verwijst. Dit programma is geschikt voor het drogen van normaal nat katoenen wasgoed en is het meest efficiënte programma op het gebied van energieverbruik voor katoen.
- ④ Van A (meest efficiënt) tot G (minst efficiënt)

SPECIFICATIES

Nominale spanning/frequentie	220-240V~ 50Hz
Nominaal vermogen	800W
Beschermingsgraad tegen vocht	IPX4
Koudemiddel	R290 / 120 g GWP: 3 CO ₂ - eq: 0 T

Hermetisch afgedicht



FR

NL

PT

EN

53





VERWIJDERING



Als verantwoordelijke handelaar dragen we zorg voor het milieu. We moedigen u aan om de juiste verwijderingsprocedure voor uw apparaat en verpakkingsmateriaal te volgen. Dit draagt bij tot het behoud van de natuurlijke rijkdommen door deze te recyclen zodat zowel de menselijke gezondheid en het milieu worden beschermd.

Gooi dit apparaat en de verpakking weg in overeenstemming met de geldende wetgeving en voorschriften.

Aangezien dit apparaat elektronische componenten bevat moet het apparaat en toebehoren aan het einde van hun levensduur afzonderlijk van het huisafval worden weggegooid.

Neem contact op met uw gemeente voor informatie over afdanking en recycling.

Lever het apparaat in bij het inzamelpunt van uw gemeente voor recycling. Bij sommige inzamelpunten kunt u het apparaat gratis inleveren.

Hotline Vanden Borre

Dienst naverkoop is bereikbaar op tel.nr. +32 2 334 00 00, van maandag tot zaterdag 8u - 18u.















We verontschuldigen ons voor enig ongemak veroorzaakt door kleine inconsistenties in deze gebruikershandleiding, die kunnen ontstaan door productverbetering of -ontwikkeling.

Etablissements Darty & fils ©,
9 Rue des Bateaux-Lavois, 94200 Ivry-sur-Seine, France 31/01/2024





ÍNDICE

	INSTRUÇÕES DE SEGURANÇA IMPORTANTES.....	56
	DICAS PARA POUPAR ENERGIA.....	59
	DESEMBALAR O APARELHO.....	59
	DESCRIÇÃO DO PRODUTO.....	60
	ANTES DE INSTALAR O APARELHO.....	62
	INSTALAÇÃO.....	62
	LIGAÇÃO ELÉTRICA.....	65
	NOTAS SOBRE CUIDADOS COM A ROUPA.....	66
	ANTES DA PRIMEIRA UTILIZAÇÃO.....	67
	FUNCIONAMENTO DA MÁQUINA DE SECAR.....	68
	LIMPEZA E MANUTENÇÃO.....	74
	RESOLUÇÃO DE PROBLEMAS.....	77
	FICHA DO PRODUTO.....	78
	CARACTERÍSTICAS TÉCNICAS	79
	ELIMINAÇÃO.....	80

FR

NL

PT

EN

55



INSTRUÇÕES DE SEGURANÇA IMPORTANTES

LEIA OS SEGUINTE AVISOS DE SEGURANÇA E AS INSTRUÇÕES CUIDADOSAMENTE ANTES DE UTILIZAR O APARELHO E GUARDE PARA FUTURAS REFERÊNCIAS.

Avisos

-  Leia as instruções.
- Este aparelho foi criado para uso doméstico e em aplicações semelhantes, como as seguintes:
 - Cozinhas em lojas, escritórios e outros ambientes de trabalho;
 - Casas de campo;
 - Por clientes em hotéis, motéis e outros ambientes do tipo residencial;
 - Ambientes do tipo residenciais com pequeno-almoço.
- Se o fio da alimentação ficar danificado, deverá ser substituído pelo fabricante, o agente de reparação ou uma pessoa igualmente qualificada, de modo a evitar quaisquer perigos.
- Este aparelho pode ser usado por crianças com mais de 8 anos de idade e pessoas com capacidades físicas, sensoriais ou mentais reduzidas, ou falta de experiência e conhecimentos, se forem supervisionadas e ensinadas quanto à utilização do aparelho de um modo seguro, e compreenderem os perigos envolvidos. As crianças não deverão brincar com o aparelho. A limpeza e manutenção não deverão ser feitas por crianças sem supervisão.
- O peso máximo do material têxtil seco em quilogramas a ser usado no aparelho é de 8 kg.
- Relativamente às instruções acerca do método de limpeza, consulte a secção "LIMPEZA E MANUTENÇÃO" nas páginas 74-76.
- Eliminação do aparelho:**
Para evitar possíveis danos para o ambiente ou para a saúde humana decorrentes de uma eliminação descontrolada dos resíduos, recicle-os de forma responsável para promover a reutilização sustentável dos recursos materiais. A eliminação





- deve ser apenas realizada através de pontos de recolha públicos.
- **Instalação, reparação:**
O aparelho deve ser colocado num piso horizontal, mantendo a ventilação desimpedida. Não tente substituir nem reparar quaisquer componentes. Peça ajuda, caso seja necessário, junto de um centro de reparação.
 - **Manuseamento:**
Manuseie sempre o aparelho para evitar qualquer dano.
 - A máquina de secar não deve ser utilizada se tiverem sido utilizados produtos químicos industriais para a limpeza.
 - O coletor de algodão tem de ser limpo frequentemente.
 - Não se deve permitir a acumulação de algodão à volta da máquina de secar.
 - É necessário prever uma ventilação adequada para evitar o refluxo de gases para o compartimento provenientes de aparelhos que queimam outros combustíveis, incluindo fogueiras.
 - Não seque os artigos não lavados na máquina de secar.
 - Os artigos que foram sujos com substâncias como óleo alimentar, acetona, álcool, gasolina, querosene, tira-nódoas, aguarrás, ceras e removedores de cera devem ser lavados em água quente com uma quantidade extra de detergente antes de serem secos na máquina de secar.
 - Artigos como espuma de borracha (espuma de látex), toucas de banho, têxteis impermeáveis, artigos com revestimento de borracha e roupas ou almofadas equipadas com almofadas de espuma de borracha não devem ser secos na máquina de secar.
 - Os amaciadores de roupa, ou produtos semelhantes, devem ser utilizados de acordo com as instruções do amaciador.
 - Remova todos os objetos dos bolsos, como isqueiros e fósforos.
 - AVISO: Nunca pare a máquina de secar antes do fim do ciclo de secagem, a menos que todos os objetos sejam rapidamente retirados e espalhados para que o calor se dissipe.
 - AVISO: O aparelho não deve ser alimentado através de um dispositivo externo de ligação, como um temporizador, ou ligado

FR

NL

PT

EN

57



a um circuito que seja ligado e desligado com regularidade por uma empresa de serviços públicos.

- As crianças com menos de 3 anos de idade deverão ser mantidas afastadas, a não ser que sejam constantemente supervisionadas.
- A alcatifa não deve obstruir as aberturas.
- O ar de exaustão não deve ser descarregado para uma chaminé utilizada para a exaustão de fumos de aparelhos a gás ou outros combustíveis.
- Este aparelho não deve ser instalado atrás de uma porta que possa ser fechada, de uma porta de correr ou de uma porta com dobradiças do lado oposto ao da máquina de secar, de modo a impedir a abertura total da porta da máquina de secar.
- A ficha tem de permanecer facilmente acessível após a instalação do aparelho.



As superfícies podem aquecer durante a utilização.



- **Aviso:** Risco de fogo/materiais inflamáveis.
- **AVISO:** Na caixa do aparelho ou na estrutura incorporada, mantenha as aberturas de ventilação livres de obstruções.
- **AVISO:** Não danifique o circuito refrigerador.

Precauções de segurança

- Não use no exterior.
- Não toque no aparelho se as mãos ou os pés estiverem húmidos ou molhados.
- Não se apoie na porta quando carregar a máquina nem utilize a porta para levantar ou deslocar a máquina.
- Não utilize o aparelho se o filtro de algodão não estiver na posição ou estiver danificado.
- Retire sempre a ficha do aparelho da tomada antes de proceder à limpeza do aparelho.
- Não continue a utilizar este aparelho se lhe parecer estar avariado.





DICAS PARA POUPAR ENERGIA

Para evitar um tempo de secagem desnecessariamente longo e um alto consumo de energia:

- Certifique-se de que a sua roupa é bem centrifugada antes de a secar.
- Carregue de acordo com a quantidade ideal de roupa recomendada para o programa que está a ser utilizado (consulte a Tabela de Programas).
- Certifique-se de que a sala em que a máquina de secar está localizada está bem ventilada.
- Certifique-se de que o filtro está limpo antes de utilizar a máquina de secar.

DESEMBALAR O APARELHO

- Este aparelho é pesado: É necessário ter cuidado ao deslocá-lo.
- Ao desembalar o aparelho, verifique se não está danificado.. Em caso de dúvida, não o utilize e contacte o Centro de Assistência.
- Todas as embalagens devem ser retiradas antes da utilização.





DESCRIÇÃO DO PRODUTO

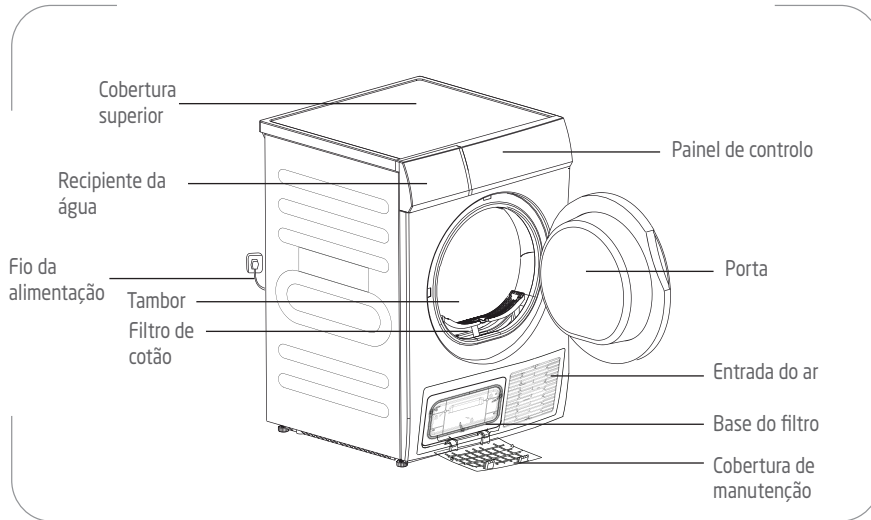

Painel de controlo

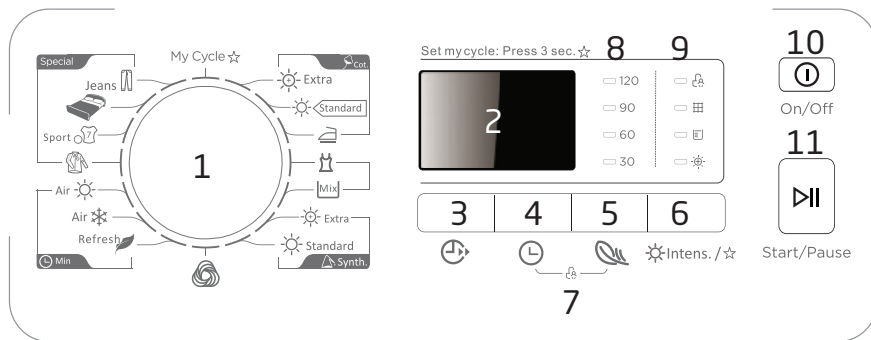

1. Botão de seleção de programas

2. Visor

Este visor é utilizado para visualizar as definições.







88:88 / 88 Tempo de secagem restante estimado / Códigos de erro





04 Hora de início retardada



3. Botão de início retardado





4.  Botão do tempo:
5.  Botão anti-vincos
6.  Intens. /  Intensidade de secagem/Botão do programa favorito
7.   Função de bloqueio para crianças
8. Indicadores luminosos para o tempo de anti-vincos
9. Indicadores luminosos

			
Bloqueio de segurança para crianças	Limpar o filtro	Depósito de água suja	Intensidade

10.  Botão de ligar/desligar
11.  Botão de Iniciar/Pausa

FR

NL

PT

EN

61



ANTES DE INSTALAR O APARELHO

Antes de ligar a sua máquina de secar à alimentação, verifique se a voltagem indicada na placa das especificações corresponde à voltagem em sua casa. Uma voltagem diferente pode danificar o aparelho.

A ficha é o único modo de desligar o aparelho da alimentação e deverá estar permanentemente acessível. Para desligar a alimentação do aparelho, desligue o aparelho e retire a ficha da tomada.

O aparelho tem de ser ligado à terra. O fabricante não se responsabiliza por danos que possam ocorrer como resultado de uma utilização sem ligação à terra.

INSTALAÇÃO

- Recomenda-se que, para sua comodidade, o aparelho seja colocado perto da sua máquina de lavar.
- O aparelho deve ser instalado num local limpo, onde a sujidade não se acumule.
- O aparelho não deve ser colocado perto de uma placa de fogão a gás, fogão, aquecedor ou grelhador, pois as chamas dos queimadores podem danificá-lo.
- Ao instalar o aparelho, certifique-se de que o cabo de alimentação não fica preso ou torcido.
- Para reduzir ao mínimo as vibrações e o ruído durante a utilização da máquina de secar, esta deve ser colocada numa superfície firme e plana.

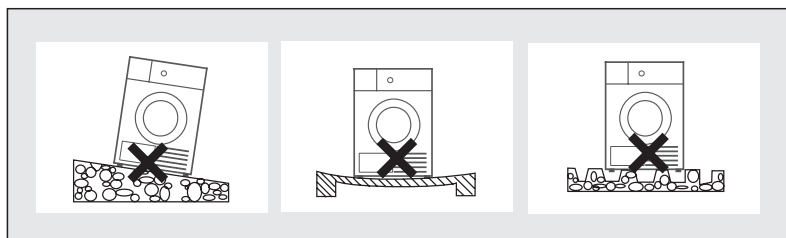



Nivelar o aparelho

A máquina de secar deve estar perfeitamente nivelada para garantir um funcionamento seguro e correto.

Se a máquina de secar não estiver bem nivelada, ajuste os pés de nivelamento, se necessário.

NÃO insira pedaços de madeira de qualquer outro objeto por baixo dos pés.



Se o aparelho for instalado num piso alcatifado, é necessário ajustar os pés para que o ar circule livremente por baixo do aparelho.



Não remova os pés. Não diminua a folga do piso através de tapetes grossos, pedaços de madeira ou equivalente. Isto pode aumentar o calor, o que pode afetar o funcionamento do aparelho.

Nivele o aparelho levantando ou baixando os pés.

Nunca coloque caixas de cartão, blocos de madeira ou materiais semelhantes debaixo da máquina para equilibrar as irregularidades ao nível do solo.

O nivelamento exato evita vibrações, ruídos e deslocações do aparelho durante o funcionamento.

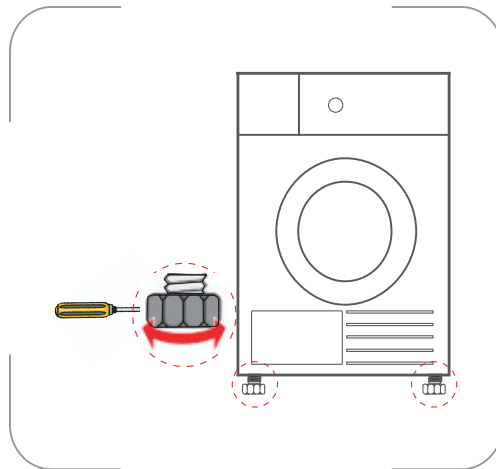

FR

NL

PT

EN

63





Instalação de acessórios

Se a sua máquina de secar tiver as seguintes peças, use luvas e instale-as de acordo com as instruções abaixo.

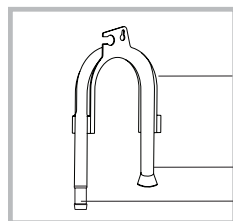

Suporte da mangueira

Mangueira de drenagem

Conetor

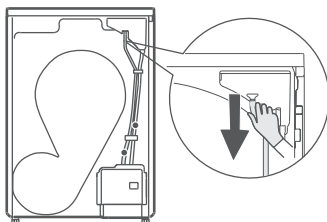

Puxar para cima a mangueira de drenagem superior.

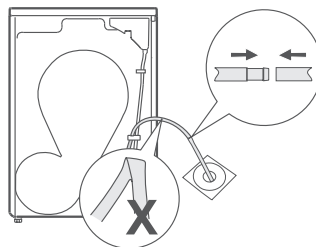

Coloque a mangueira de drenagem externa no ralo do chão.
(Tenha cuidado para não dobrar a mangueira de drenagem externa).





LIGAÇÃO ELÉTRICA

Perigo:

Para fazer a ligação elétrica ao seu aparelho:

- A instalação na rede elétrica deve estar em conformidade com as normas e os regulamentos locais.
- Não utilize um fio de extensão, um adaptador ou algo similar.
- A ficha tem de estar facilmente acessível após a instalação do aparelho.
- Se tiver dúvidas sobre o estado da sua ligação, consulte um electricista qualificado.



Aviso! O fabricante declina qualquer responsabilidade por danos ou ferimentos resultantes do não cumprimento das precauções de ligação elétrica acima referidas.



FR

NL

PT

EN

65





NOTAS SOBRE CUIDADOS COM A ROUPA

Etiquetas de cuidados com a roupa

As roupas têm as suas próprias etiquetas de cuidados de lavagem, pelo que se recomenda a secagem de acordo com a etiqueta de cuidados de lavagem abaixo.

 Secar	 Secar na máquina	 Não secar na máquina.	 Não secar
 Secagem em linha/ pendurar para secar	 Secagem por goteja- mento	 Secar em plano	 Na sombra
 Limpar a seco	 Não limpar a seco.	 Limpar a seco, qualquer solvente	 Limpar a seco, apenas solvente de petróleo

As peças de vestuário novas de cor escura devem ser lavadas e secas separadamente das peças de vestuário de cor clara para evitar o perigo de as cores escorrerem e descolorarem outras peças de vestuário ou mesmo componentes de plástico na máquina de secar. As fibras de cor escura podem também assentar em peças de vestuário de cor clara e vice-versa.

Borracha e plásticos

Não seque artigos feitos de ou que contenham borracha ou plástico, tais como:

- a. aventais, babetes e coberturas de cadeiras
- b. cortinados e toalhas de mesa
- c. tapetes de banho

Roupas de bebé e vestidos de noite

Verifique sempre as etiquetas de cuidados do fabricante.





Vestuário de prensagem permanente







Retire as peças de vestuário de prensagem permanente assim que a máquina de secar parar para reduzir os vincos.

Vestuário de malha

Algumas peças de vestuário em malha, como as t-shirts e a roupa interior, tendem a encolher, dependendo da sua qualidade. Não seque demasiado estes têxteis.

Capacidade de carga

Os pesos seguintes são indicados apenas a título de referência.

	Vestuário de tecido misto (800g)		Casaco (800g)		Calças de ganga (800g)
	Lençol de cama (600g)		Panos de trabalho (1120g)		Roupa de dormir (200g)
	Camisas de manga curta (180g)		Calças curtas (70g)		Meias (50g)
	Colcha de retalhos (900g)		Camisa de manga comprida (300g)		

ANTES DA PRIMEIRA UTILIZAÇÃO

Para eliminar os resíduos que possam ter sido deixados durante a produção, limpe o tambor da máquina de secar com um pano húmido ou efetue um breve ciclo de secagem com a roupa húmida na máquina de secar.

FR

NL

PT

EN

67





FUNIONAMENTO DA MÁQUINA DE SECAR

- 1 **Abra a porta.**
- 2 **Verifique se o filtro e o tambor estão limpos.**
 - Caso contrário, limpe-os consultando a secção Limpeza e manutenção.

- 3 **Coloque a roupa solta no tambor após a triagem.**

- As roupas devem ser selecionadas de acordo com os tipos de fibras e o nível de secagem necessário. Todos os cordões e cintos da roupa devem ser bem atados e fixados antes de serem colocados no tambor.
- Não sobrecarregue o tambor (consulte a "Tabela de Programas" para obter recomendações sobre as

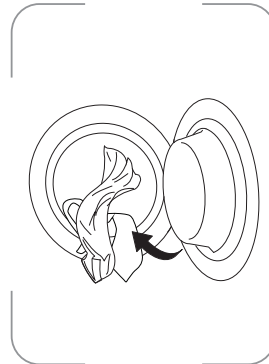

CUIDADO:





Não seque roupas não lavadas na máquina de secar.

- 4 **Feche a porta.**

- Antes de fechar a porta, verifique se a roupa está bem dentro do tambor para que não fique presa ou danificada.

- 5 **Prima  para ligar a máquina de secar.**

- 6 **Selecione um programa rodando o botão de seleção de programas para a posição desejada.**

- O visor apresenta o tempo restante do programa selecionado.
- Se seleccionar um dos programas de horário, (Quente Air  , Frio Air  , Refrescar Refresh ) pode definir o tempo de secagem premindo repetidamente  .

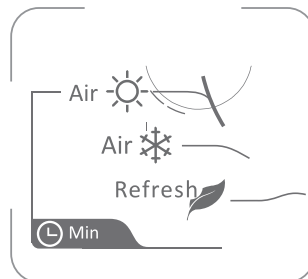





- 7 **Selecione a função anti-vincos quando necessário.**

Pode utilizar esta função para evitar que a roupa fique amarrotada se não retirar





a roupa após o fim do programa.

 Pode premir repetidamente para seleccionar 30, 60, 90 ou 120 horas. No final do ciclo de secagem, o tempo de anti-vincos predefinido é de 30 minutos. Esta função não está disponível para os programas Air , Refresh  e .

8 Pode ativar a função de intensidade da secagem premindo

 Intens. / ☆.

O tempo de secagem aumentará em 10 minutos. O indicador luminoso  acende.

Para desativar esta função, prima  Intens. / ☆ novamente e o indicador luminoso  desliga-se.

 **NOTA:** Esta função pode ser seleccionada com os programas mostrados abaixo.

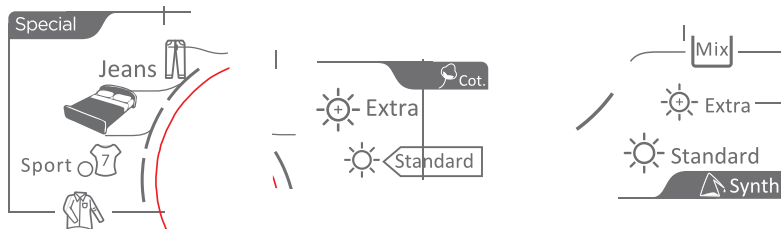

9 Prima .

10 Depois de terminado o ciclo, ouve-se um sinal sonoro e o visor indica "Fim".

11 Abra a porta e retire a roupa.

FR

NL

PT

EN





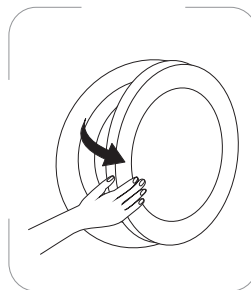

Cuidado! O tambor interno ainda pode estar quente.

Verifique se todos os artigos foram removidos do tambor. Se deixar artigos na máquina de secar, estes podem ficar danificados por secagem excessiva quando a máquina for utilizada de novo.



12 Limpe os filtros conforme descrito na seção Limpeza e manutenção.

- Para evitar odores desagradáveis e conservar melhor a vedação da porta, mantenha a porta do aparelho ligeiramente aberta até ao próximo ciclo de secagem.
- O indicador acende  e  acenderá para lembrá-lo de limpar o filtro e esvaziar o depósito da água.



















13 Desligue o aparelho da tomada elétrica se não for utilizado durante longos períodos.





Tabela de programas

Siga a carga de roupa recomendada quando utilizar o programa atribuído. Os valores indicados no quadro seguinte são meramente informativos.

Tipo de roupa	Programa de secagem	Capacidade (kg)	Tempo de secagem (minutos)	Para secagem
 Cot. Algodão	 Extra	8	220	Tecidos de algodão, como toalhas, t-shirts, roupas íntimas e roupa de cama
	 Standard		200	
	 Ferro de engomar		180	
 Delicado	Delicado	1	85	Roupa delicada que seja adequada para secar ou roupa que seja aconselhável ser lavada à mão a uma temperatura mais baixa.
 Mix	Misto	3,5	110	Tecidos sintéticos e de algodão não tingidos
 Synth. Sintético	 Extra	3,5	100	Tecidos sintéticos, como camisas, blusas e lingerie
	 Standard		90	
 Lã	Lã	1	25	Tecidos de lã
 Min Hora	Air  Ar quente	–	10	Para secar pequenas cargas de roupa com ar quente de 10 minutos a 120 minutos em etapas de 10 minutos
	Air  Ar frio	–	10	Para secar pequenas cargas de roupa com ar frio de 10 minutos a 30 minutos em etapas de 10 minutos
	Refresh  Refrescar	1	20	Para refrescar as roupas que estiveram em ambientes fechados durante muito tempo, do mínimo de 20 minutos ao máximo de 150 minutos em etapas de 10 minutos
Special	Jeans 	4,0	190	Calças de ganga e roupas de lazer
	Roupa de cama 	4,0	170	Para secar roupa de cama ou outros têxteis de grandes dimensões
	Sport 	3,0	80	Roupa desportiva, tecidos finos, poliéster que não são passados a ferro
	Camisas 	1,0	80	Roupas fáceis de cuidar, como camisas e blusas

FR

NL

PT

EN

71





Nota!

-  Este símbolo representa o programa de teste de eficiência energética “programa de algodão normalizado”, que está em conformidade com a norma EN 61121 aplicável e é o mais adequado para secar a carga normal de algodão com a capacidade de carga nominal.
- Os tecidos grossos ou com várias camadas, por exemplo, roupa de cama, calças de ganga, etc., não são fáceis de secar. Recomenda-se escolher o programa Algodão Extra.
- Uma vez que os materiais irregulares, as roupas grossas e com várias camadas não são fáceis de secar, é melhor escolher o programa de secagem de tempo adequado para as secar se algumas partes da roupa ainda estiverem húmidas depois de o programa estar concluído.

Início retardado

O ciclo de secagem pode ser retardado em até 24 horas. Para ativar essa função de início retardado, proceda da seguinte forma:



1. Selecione o programa desejado.
2. Prima repetidamente  para aumentar o tempo de atraso em 1 hora, até 24 horas.
 - O visor apresenta o tempo de atraso.
3. Prima  para confirmar.
4. Depois de decorrido o tempo de atraso, o programa selecionado é iniciado.

Para cancelar o início retardado:

Se quiser cancelar o início retardado e iniciar o programa, desligue a máquina de secar e volte a ligá-la.

Seleção de programas favoritos.

Pode guardar um programa favorito que seja utilizado frequentemente.

1. Rode o botão de seleção de programas para selecionar um programa. Selecione as funções de opção, se necessário.
2. Prima e mantenha premido  durante cerca de 3 segundos. O programa e as opções definidos são guardados.
3. Pode rodar o botão de programas para a posição My Cycle  para iniciar o







seu programa e respetivas opções favoritos.

Bloqueio de segurança para crianças

Pode utilizar esta função para evitar que as crianças brinquem com a máquina de secar.

O botão de programas e todos os botões, exceto o botão  são desativados quando a função de bloqueio para crianças está ativa.

Para desativar esta função, prima novamente e mantenha premido  e  em simultâneo durante 3 segundos.

O indicador luminoso de desbloqueio para crianças  acende.

Para desativar esta função, prima novamente e mantenha premidos em simultâneo os mesmos botões durante cerca de 3 segundos. O indicador luminoso do bloqueio para crianças apaga-se.

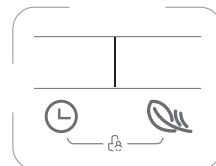



LIMPEZA E MANUTENÇÃO



Desligue o aparelho e retire a ficha da tomada antes de efetuar a limpeza ou manutenção.

Nunca utilize qualquer agente de limpeza abrasivo ou químico.

Limpeza externa

Limpe regularmente o exterior do aparelho com um pano húmido ligeiramente macio. Seque bem.

Limpeza da superfície interior da porta

Limpe sempre a superfície interior da porta após cada processo de secagem.

Limpe a parte interior da porta e a junta da porta com um pano macio e húmido para remover qualquer penugem.



Limpeza do filtro de algodão

O filtro recolhe a penugem que se acumula durante a secagem e deve ser retirado e limpo após cada processo de secagem.

O indicador luminoso de aviso  acenderá para lembrá-lo de limpar o filtro de algodão.

1. Puxe o filtro de algodão para cima e para fora do aparelho.
2. Abra o filtro de algodão e remova quaisquer fios ou algodão à mão ou com uma escova macia.
Lave com água corrente.

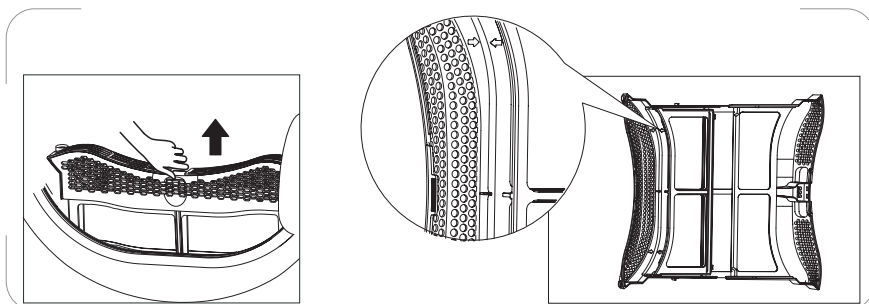

3. Feche o filtro de algodão e volte a colocá-lo na posição.





Drenagem do depósito da água

Drene o depósito da água após cada processo de secagem. Para drenar o depósito da água:

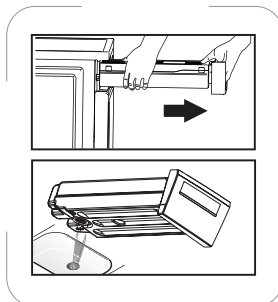

1. Puxe o depósito de água e retire-o cuidadosamente.
2. Esvazie a água do depósito.
3. Volte a colocar o depósito da água na respetiva posição.



A água condensada não é potável!



Nunca retire o depósito da água quando o aparelho estiver a funcionar!

Se se esquecer de esvaziar o depósito da água, o aparelho para durante a secagem quando o depósito da água estiver cheio e o indicador luminoso de aviso  acende-se. Nesse caso, drene o depósito da água e prima  para retomar o ciclo de secagem.

Limpeza da base do filtro

Limpe a base do filtro após cada processo de secagem.

1. Se tiver sido efetuado um processo de secagem, abra a tampa da base do filtro e aguarde que arrefeça.
2. Desbloqueie os 3 fechos da base do filtro. Retire a base do filtro.
3. Limpe a base do filtro com água corrente. Seque bem.
4. Se necessário, limpe o permutador de calor de 2 em 2 meses.

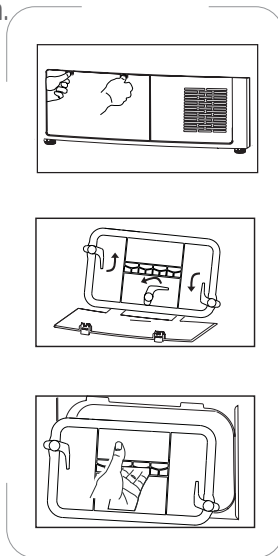

FR

NL

PT

EN

75





Não toque no permutador de calor com a mão!

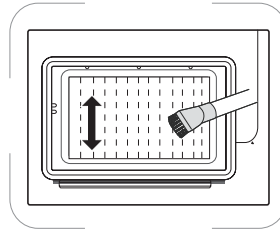



Retire a penugem do permutador de calor utilizando um aspirador com uma escova para o pó. Limpe o permutador de calor sem aplicar pressão.

5. Volte a colocar a base do filtro na posição. Aperte os 3 fechos e certifique-se de que estão bem fixos.
6. Feche a cobertura até ouvir um clique.





RESOLUÇÃO DE PROBLEMAS

Problemas	Possíveis Soluções
A máquina de secar não inicia.	Verifique se a porta está devidamente fechada.
	Verifique se o programa está definido.
	Verificar se o botão de iniciar  está premido.
O visor não está ligado.	Verifique se a fonte de alimentação funciona.
	Verifique se a ficha de alimentação está inserida.
	Verifique se o programa está definido.
	Verifique se o botão da alimentação  está premido.
O grau de secagem não é atingido.	Limpe o filtro de algodão e o permutador de calor.
	Esvazie o recipiente.
	Verifique a mangueira de drenagem.
	O local de instalação da máquina de secar é muito restrito.
	Utilize um programa de maior nível de secagem.

 Se não consegue lidar com os problemas sozinho e precisa de ajuda,

- prima  para desligar o aparelho e retirar a ficha da tomada.
- Contacte o serviço pós-venda.

Códigos de Erro

Visor	Causa	Solução
E32	Erro no sensor da humidade.	Se ocorrer um erro, contacte o serviço pós-venda local.
E33	Erro no sensor da temperatura.	
E82	Erro de comunicação:	

FR

NL

PT

EN

77





FICHA DO PRODUTO

A ficha de produto desta máquina de secar foi elaborada em conformidade com o Regulamento (UE) n.º 392/2012.

Marca	Proline	
Modelo	PROHP82	
Capacidade nominal de roupa de algodão para o programa normal de algodão em carga máxima	8 kg	
Tipo de secagem	Condensador	
Classe de eficiência energética ¹	A++	
Consumo anual ponderado de energia (AEC) ²	235 kWh/ano	
Processo de secagem	Máquina de secar automática	
Consumo de energia do programa normal de algodão	em carga máxima (E _{seco})	1,78 kWh
	em carga parcial (E _{1/2seco})	1,01 kWh
Consumo de energia para o programa normal de algodão em carga máxima	modo desligado (P _o)	0,43 W
	modo ligado (P _i)	0,52 W
Duração do modo ligado	10 minutos	
Programa de secagem normal ³		
Tempo de programa ponderado (T _p) do programa de algodão normal em carga máxima e parcial	143 minutos	
Tempo do programa do programa normal de algodão	em carga máxima (T _{seco})	210 minutos
	em carga parcial (T _{1/2seco})	110 minutos
Classe de eficiência de condensação ⁴	B	
Condensação média eficiência do programa normal de algodão	em carga máxima (C _{seco})	84 %
	em carga parcial (C _{1/2seco})	84 %
Eficiência de condensação ponderada (C _t) para o programa normal de algodão em carga máxima e parcial	84 %	
Nível de potência sonora (valor médio ponderado -L _{WA}) para o programa normal de algodão em carga máxima	65 dB	
Aparelho encastrado S/N	Não	

¹ De A+++ (mais eficiente) a D (menos eficiente)

² Consumo de energia 235 kWh por ano, com base em 160 ciclos de secagem do programa normal de algodão em carga máxima e parcial, e no consumo dos modos de baixo consumo. O consumo real de energia por ciclo dependerá da forma como o aparelho é utilizado.





- 3 O "programa normal para algodão" utilizado em carga total e parcial é o programa de secagem normal a que se referem as informações constantes do rótulo e da ficha, segundo as quais este programa é adequado para secar roupa normal de algodão molhada e é o programa mais eficiente em termos de consumo de energia para o algodão.
- 4 De A (mais eficiente) a G (menos eficiente)



CARACTERÍSTICAS TÉCNICAS

Voltagem nominal/frequência	220-240V~ 50Hz
Potência nominal	800W
Grau de impermeabilidade	IPX4
Refrigerante	R290 / 120 g GWP: 3 CO ₂ - eq: 0 T

Selado hermeticamente



FR

NL

PT

EN

79





ELIMINAÇÃO



Como um retalhista responsável, nós cuidamos do meio ambiente. Como tal, pedimos-lhe que siga o procedimento correto para a eliminação do produto e materiais de empacotamento. Isto irá ajudar a preservar os recursos naturais e assegurar que os materiais sejam reciclados de forma a proteger a saúde e o meio ambiente.

Tem de eliminar este aparelho e material de empacotamento de acordo com as leis e normas locais.

Como este aparelho contém componentes eletrónicos, o aparelho e respetivos acessórios têm de ser eliminados em separado do lixo doméstico comum quando o aparelho chegar ao fim do seu tempo de vida.

Contacte as autoridades locais para saber mais acerca da eliminação e reciclagem. O aparelho deverá ser entregue no seu ponto de recolha local para se proceder à reciclagem. Alguns pontos de recolha aceitam o aparelho livre de encargos.















Pedimos desculpa por qualquer inconveniente causado por inconsistências menores nestas instruções, as quais podem ocorrer como resultado da melhoria e desenvolvimento do produto.

Etablissements Darty & fils ©,
9 Rue des Bateaux-Lavours, 94200 Ivry-sur-Seine, France 31/01/2024





TABLE OF CONTENTS

	IMPORTANT SAFETY INSTRUCTIONS.....	82
	ENERGY SAVING TIPS.....	85
	UNPACKING THE APPLIANCE.....	85
	PRODUCT DESCRIPTION.....	86
	BEFORE INSTALLING THE APPLIANCE.....	88
	INSTALLATION.....	88
	ELECTRICAL CONNECTION.....	91
	NOTES ON LAUNDRY CARE.....	91
	BEFORE FIRST USE.....	93
	OPERATING THE DRYER.....	94
	CLEANING AND MAINTENANCE.....	99
	TROUBLESHOOTING.....	102
	PRODUCT FICHE.....	103
	SPECIFICATIONS.....	104
	DISPOSAL.....	105



IMPORTANT SAFETY INSTRUCTIONS

PLEASE READ THE FOLLOWING SAFETY WARNINGS AND THE INSTRUCTIONS CAREFULLY BEFORE USING THE APPLIANCE AND KEEP FOR FUTURE REFERENCE.

Warnings

-  Read the instructions.
- This appliance is intended to be used in household and similar applications such as:
 - staff kitchen areas in shops, offices and other working environments;
 - farm houses;
 - by clients in hotels, motels and other residential type environments;
 - bed and breakfast type environments.
- If the supply cord is damaged, it must be replaced by the manufacturer, its service agent or similarly qualified persons in order to avoid a hazard.
- This appliance can be used by children aged from 8 years and above and persons with reduced physical, sensory or mental capabilities or lack of experience and knowledge if they have been given supervision or instruction concerning use of the appliance in a safe way and understand the hazards involved. Children shall not play with the appliance. Cleaning and user maintenance shall not be made by children without supervision.
- The maximum mass of dry textile material in kilograms to be used in the appliance is 8 kg.
- Regarding the instructions for the method of cleaning, refer to the section "CLEANING AND MAINTENANCE" in pages 99-101.
- For disposal of the appliance :**
To prevent possible harm to the environment or human health from uncontrolled waste disposal, recycle it responsibly to promote the sustainable reuse of material resources. And the disposal should only be done through public collection points.





- **For installation, servicing :**

The appliance should be placed on a horizontal floor and keep the ventilation freely. Don't try to replace or repair any components by yourself, ask the service agency for help if necessary.

- **For handling :**

Always handle the appliance to avoid any damage.

- The tumble dryer is not to be used if industrial chemicals have been used for cleaning.
- The lint trap has to be cleaned frequently.
- Lint must not be allowed to accumulate around the tumble dryer.
- Adequate ventilation has to be provided to avoid the back flow of gases into the room from appliances burning other fuels, including open fires.
- Do not dry unwashed items in the tumble-dryer.
- Items that have been soiled with substances such as cooking oil, acetone, alcohol, petrol, kerosene, spot removers, turpentine, waxes and wax removers should be washed in hot water with an extra amount of detergent before being dried in the tumble dryer.
- Items such as foam rubber (latex foam), shower caps, waterproof textiles, rubber backed articles and clothes or pillows fitted with foam rubber pads should not be dried in the tumble dryer.
- Fabric softeners, or similar products, should be used as specified by the fabric softener instructions.
- Remove all objects from pockets such as lighters and matches.
- **WARNING:** Never stop a tumble dryer before the end of the drying cycle unless all items are quickly removed and spread out so that the heat is dissipated.
- **WARNING:** The appliance must not be supplied through an external switching device, such as a timer, or connected to a circuit that is regularly switched on and off by a utility.
- Children of less than 3 years should be kept away unless continuously supervised.
- A carpet must not obstruct the openings.

FR

NL



PT

EN

83





- Exhaust air must not be discharged into a flue which is used for exhausting fumes from appliances burning gas or other fuels.
- This appliance must not be installed behind a lockable door, a sliding door or a door with hinges on the opposite side to that of the tumble dryer, in such a way that a full opening of the tumble dryer door is restricted.
- The plug must be remained easily accessible after installation of the appliance.
-  The surfaces are liable to get hot during use.
-  Warning; Risk of fire/Flammable materials
- **WARNING:** In the appliance enclosure or in the built-in structure, keep ventilation openings clear of obstruction.
- **WARNING:** Do not damage the refrigerant circuit.

Safety Precautions

- Do not use outdoors.
- Do not touch the appliance when hands or feet are damp or wet.
- Do not lean on the door when loading the machine or use the door to lift or move the machine.
- Do not operate the appliance if the lint filter is not in position or is damaged.
- Always remove the plug from the mains socket before cleaning the appliance.
- Do not continue to operate this appliance if it appears to be faulty.





ENERGY SAVING TIPS

To avoid unnecessarily long drying time and high consumption of energy:

- Make sure that your laundry is thoroughly spun before drying.
- Load according to the optimum amount of laundry recommended for the program being used (see Program Chart).
- Make sure the room in which the dryer is located is well ventilated.
- Make sure the filter is clean before using the dryer.



UNPACKING THE APPLIANCE

- This appliance is heavy. Care should be taken when moving it.
- When unpacking the appliance, check that it is not damaged. If in doubt, do not use it and contact the Service Center.
- All packaging must be removed before use.



FR

NL

PT

EN

85





PRODUCT DESCRIPTION

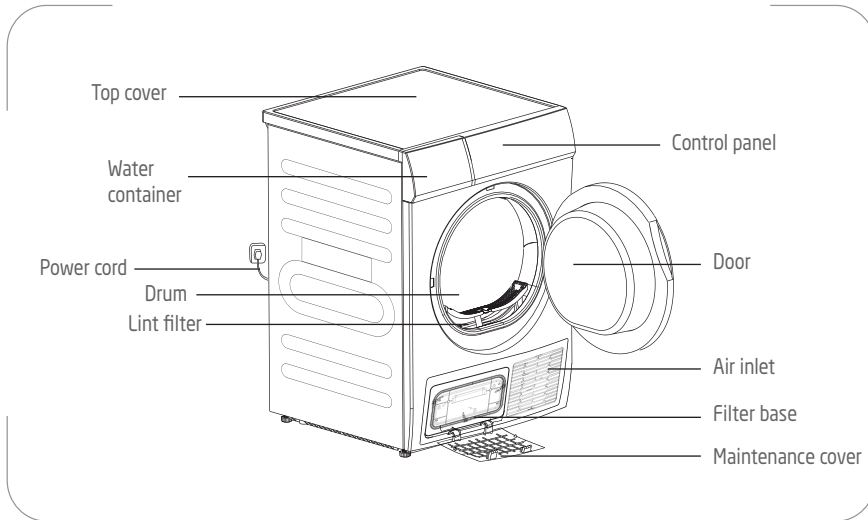



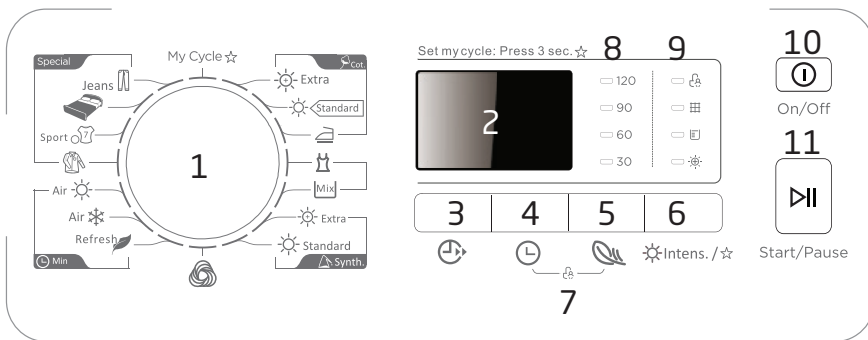



Control Panel









1. Program selection knob
2. Display
This display is used for displaying settings.
88:88 / 88 Estimated remaining drying time / Error codes
04 Delayed start time
3. Delayed start button





4.  Time button
5.  Anti-crease button
6.  Intens. /  Drying intensity / Favourite program button
7.   Child lock buttons
8. Indicator lights for anti-crease time
9. Indicator lights

			
Child lock	Clean filter	Empty water tank	Intensity

10.  On/Off button
11.  Start/Pause button



FR

NL

PT

EN

87





BEFORE INSTALLING THE APPLIANCE

Before connecting your dryer to the power supply, check that the voltage stated on the rating label of your appliance corresponds to the voltage in your home. A different voltage could damage the appliance.

The plug is the only way to unplug the appliance and should therefore be accessible at all times. To turn off main power to the appliance, turn it off and then detach the plug from the outlet.

The appliance must be grounded. The manufacturer is not responsible for damages that may occur as a result of usage without grounding.



INSTALLATION

- It is recommended that, for your convenience, the appliance is positioned close to your washing machine.
- The appliance must be installed in a clean place, where dirt does not build up.
- The appliance should not be located near a gas hob, cooker, heater or grill, as flames from the burners could damage it.
- When installing the appliance, make sure that the power cord is not trapped or twisted.
- To keep vibration and noise to a minimum when the dryer is in use, it should be placed on a firm, level surface.

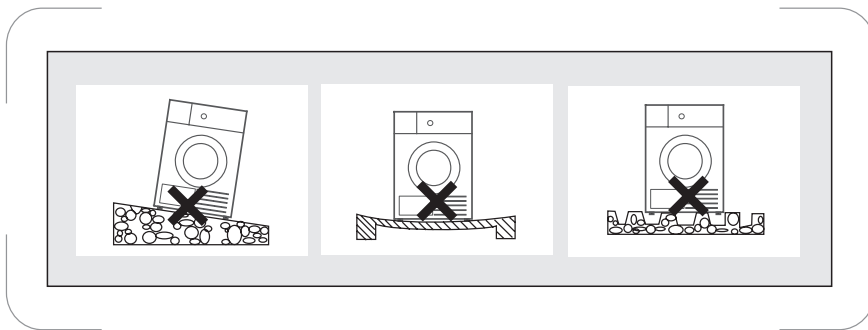



Levelling the appliance

The dryer must be perfectly level to ensure safe and proper operation. If the dryer is not properly level, adjust the levelling feet as necessary. DO NOT insert pieces of wood or any other object under the feet.

- ⚠ If the appliance is installed on a carpeted floor, please adjust the feet in order to allow air to circulate freely under the appliance.
- ⚠ Do not remove the feet. Do not decrease the floor clearance through thick carpets, pieces of wood or equivalent. This can increase the heat which can affect the operation of the appliance.

Level the appliance by raising or lowering the feet. Never put cartons, wooden blocks or similar materials under the machine to balance the irregularities on the level of the ground. Accurate levelling prevents vibration, noise and displacement of the appliance during operation.

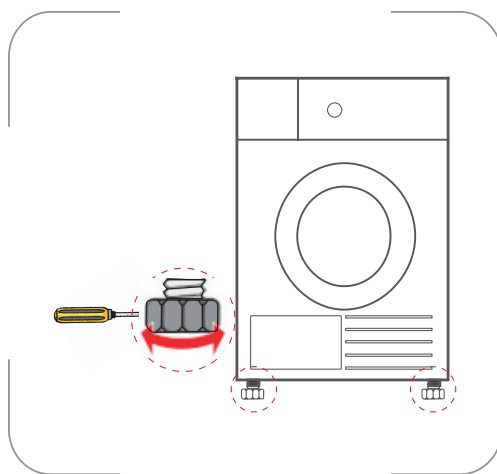

FR

NL

PT

EN

89





Installing accessories

If your dryer has the following parts, please wear gloves and install them as per the instruction below.

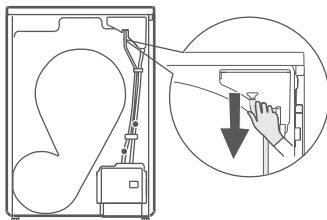
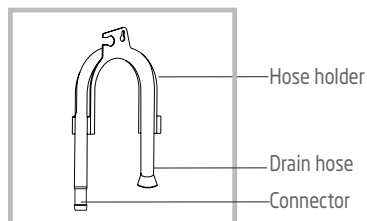

Pull up the upper drain hose.

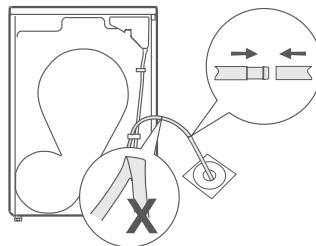

Put the external drain hose into the floor drain.
(Be careful not to bend the external drain hose.)





ELECTRICAL CONNECTION

Danger:

To make the electrical connection to your appliance :

- The installation to the mains supply must conform to the local standards and regulations.
- Do not use an extension cord, an adapter or the like.
- The plug must be easily accessible after installing the appliance.
- If there is any doubt about the condition of your connection, consult a qualified electrician.







Warning ! The manufacturer declines any responsibility for damage or injury through failure to comply with the electrical connection precautions above.

NOTES ON LAUNDRY CARE

Laundry care labels

Clothes have their own wash care labels, so drying according to the wash care label below is recommended.

 Dry	 Tumble dry	 Do not tumble dry	 Do not dry
 Line dry / hang to dry	 Drip dry	 Dry flat	 In the shade
 Dry clean	 Do not dry clean	 Dry clean, any solvent	 Dry clean, petroleum solvent only

FR

NL

PT

EN

91



New dark coloured garments should be washed and dried separately from light coloured garments to avoid the danger of colours running and discolouring other garments or even plastic components in the dryer. Dark coloured fibres can also settle on light coloured garments and vice versa.

Rubber and plastics

Do not dry any items made from or containing rubber or plastics such as:

- a. aprons, bibs and chair covers
- b. curtains and table clothes
- c. bathmats

Baby clothes and night gowns

Always check the manufacturer's care labels.

Permanent press garments









Take out permanent press garments as soon as the dryer stops to reduce creases.

Loop knit garments

Some loop knit garments such as T-shirts and underwear tend to shrink depending on their quality. Do not over-dry these textiles.

Load capacity

Following weights are given only for reference.

	Mixed-fabric clothes (800g)		Jacket (800g)		Jeans (800g)
	Bed sheet (600g)		Work cloths (1120g)		Pyjama (200g)
	Short-sleeve shirts (180g)		Short pants (70g)		Socks (50g)





Towel quilt
(900g)



Long sleeve
shirt (300g)



BEFORE FIRST USE

In order to remove any residues which may have been left during production, wipe the dryer drum with a damp cloth or carry out a brief drying cycle with damp clothes in the dryer.



FR

NL

PT

EN

93





OPERATING THE DRYER

1 Open the door.

2 Check the filter and drum are clean.

- If not, clean them referring to the section Cleaning and Maintenance.

3 Place laundry loosely into the drum after sorting.

- The clothes should be sorted according to the types of fibres and the drying level required. All the strings and belts of clothes should be well tied and fixed before being put into the drum.
- Do not overload the drum (see the "Program Chart" for recommended loads for each program).

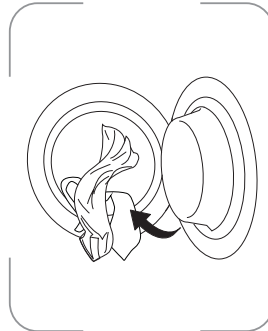

CAUTION:





Do not dry unwashed clothes in the tumble dryer.

4 Close the door.

- Before you close the door, check the laundry is right inside the drum so that it cannot get trapped or damaged.



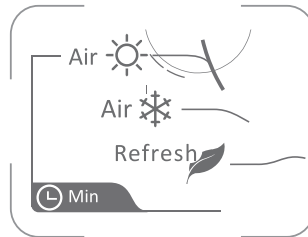

5. Press  to turn on the tumble dryer.

6 Select a program by turning the program selection knob to the desired position.

- The display will show the remaining time for the program you have selected.
- If you select one of the time programs, (Warm Air , Cool Air , Refresh Refresh ) you can set the drying time by repeatedly pressing .



7 Select the anti-crease function when needed.

You can use this function to prevent laundry from creasing if you will not take the laundry out after the program has come to an end. You can repeatedly press  to select 30, 60, 90 or 120 minutes. At the end of the drying cycle, the default anti-crease time is 30 minutes. This function is not available for the Air , Refresh  and  programs.

8 You can activate the drying intensity function by pressing  Intens. / .





The drying time will increase by 10 minutes. The indicator light  will illuminate.

To deactivate this function, press  Intens. /  again and the indicator light  will go out.

 **NOTE:** This function can be selected with the programs shown below.

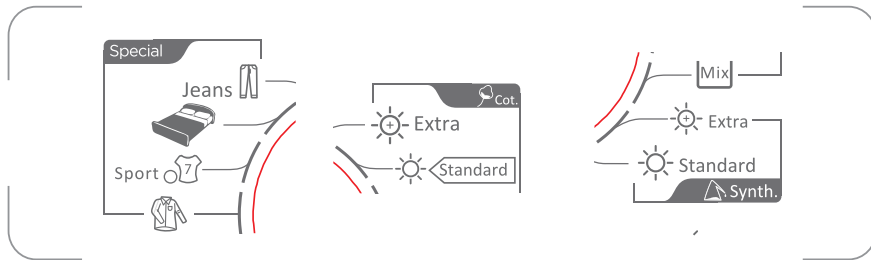

9 Press ▷|.

10 After the cycle is finished, you can hear beeps and the display will show "End".



11 Open the door and remove the laundry.

 **Careful ! The drum inside could still be hot.**

Check that all items have been removed from the drum. If items are left in the dryer, they could be damaged by over drying when the dryer is next used.



12 Clean the filters as described in the section Cleaning and Maintenance.

- To prevent unpleasant odours and better maintain the door seal, keep the appliance door slightly open until the next drying cycle.
- The indicator lights  and  will illuminate to remind you to clean the filter and empty the water tank.



















13 Disconnect the appliance from the mains socket if it is not in use for long periods.





Program chart

Please follow the recommended laundry load when you use the assigned program. The values in the table below are for information purpose only

Type of Laundry	Drying program	Capacity (kg)	Drying time (minutes)	For drying
 Cot. Cotton	 Extra	8	220	Cotton fabrics such as towels, T-shirts, underwear and bed linen
	 Standard		200	
	 Iron		180	
	Delicate	1	85	Delicate laundry that is suitable for drying or laundry which is advised to be hand-washed at a lower temperature.
	Mix	3,5	110	Non-dyed synthetic and cotton fabrics
 Synth. Synthetics	 Extra	3,5	100	Synthetic fabrics such as shirts, blouses and lingerie
	 Standard		90	
	Wool	1	25	Woolen fabrics
 Min Time	Air  Warm air	–	10	To dry small loads of laundry with warm air from 10 minutes up to 120 minutes in 10-minute steps
	Air  Cool air	–	10	To dry small loads of laundry with cool air from 10 minutes up to 30 minutes in 10-minute steps
	Refresh 	1	20	To refresh the clothes that have been kept at closed environments for a long time from minimum 20 minutes to maximum 150 minutes in 10-minute steps
Special	Jeans 	4,0	190	Jeans and leisure clothes
	Bed linen 	4,0	170	To dry bed linen or other large sized textiles
	Sport 	3,0	80	Sportswear, thin fabrics, polyester which are not ironed
	Shirts 	1,0	80	Easy care clothes such as shirts and blouses







Note !

-  This symbol means the energy efficiency test program “standard cotton program”, which is in accordance with the applicable EN 61121 standard and most suitable to dry normal cotton load at rated load capacity.
- Thick or multi-layered fabrics, e.g. bed linen, jeans, etc. are not easy to dry. It is recommended to choose Cotton Extra program.
- As the uneven material, thick and multi-layered clothes are not easy to dry, it is better to choose the appropriate time drying program to dry them if some parts of the clothes still are damp after the program is finished.

Delayed start

The drying cycle can be delayed by up to 24 hours. To activate this delayed start function, please proceed as follows:



1. Select the desired program.
2. Repeatedly press  to increase the delay time by 1 hour, up to 24 hours.
 - The display will show the delay time.
3. Press  to confirm.
4. Once the delay time has elapsed, the selected program will start.

To cancel the delayed start :

If you want to cancel the delayed start and start the program, switch off the dryer and then switch it back on.

Favorite program selection

You can save a favorite program that is used frequently.



1. Turn the program selection knob to select a program. Select the option functions if required.
2. Press and hold  for about 3 seconds. The set program and options will be saved.
3. You can turn the program knob to the My Cycle  position to start your favorite program and options.



Child lock

You can use this function to prevent children from playing with your dryer.

The program knob and all buttons except the button  are deactivated when the child lock function is active.

To activate this function, press and hold  and  at the same time for about 3 seconds. The child lock indicator light  will illuminate.

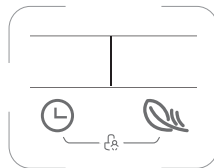

To deactivate this function, press and hold the same buttons for about 3 seconds again. The child lock indicator light will go out.





CLEANING AND MAINTENANCE



Turn off and unplug the appliance from the mains socket before carrying out any maintenance or cleaning.
Never use any abrasive or chemical cleaning agent.

External Cleaning

Regularly wipe the outside of the appliance with a slightly soft damp cloth. Dry thoroughly.

Cleaning the Door Inner Surface

Always clean the door inner surface after each drying process.

Wipe the interior part of the door and door gasket with a soft damp cloth to remove any fluff.

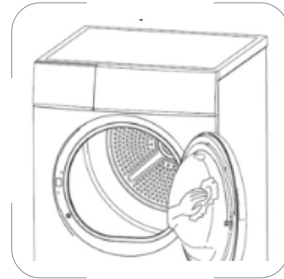

Cleaning the Lint Filter

The filter collects fluff which accumulates during drying and it must be removed and cleaned after each drying process.

The warning indicator light  will illuminate to remind you of cleaning the lint filter.

1. Pull the lint filter upwards and away from the appliance.
2. Open the lint filter and remove any threads or fluff by hand or with a soft brush.
Clean it under running water.

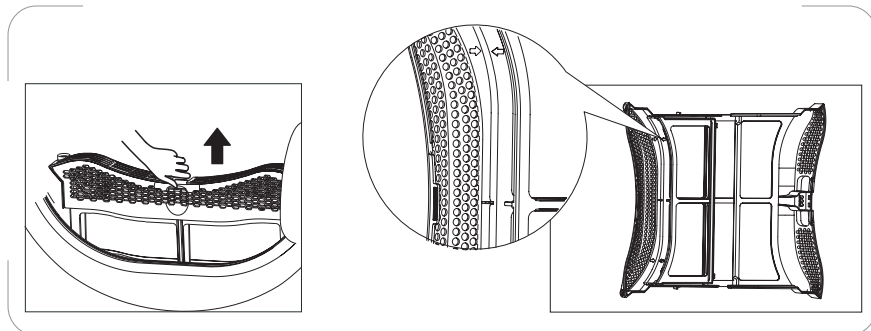

3. Close the lint filter and place it back into position.





Draining the Water Tank

Drain the water tank after each drying process. To drain the water tank:

1. Pull the water tank and remove it carefully.
2. Drain the water in the tank.
3. Place the water tank back into position.





Condensed water is not drinkable!

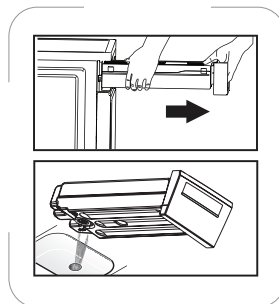

Never remove the water tank when the appliance is operating!



If you forget to drain the water tank, the appliance will stop during drying when the water tank is full and the warning indicator light  will illuminate. In this case, drain the water tank and press  to resume the drying cycle.

Cleaning the Filter Base

Clean the filter base after each drying process.

1. If a drying process has been carried out, open the cover of the filter base and wait until it cools down.
2. Unlock the 3 filter base locks. Pull out the filter base.
3. Clean the filter base under running water. Dry thoroughly.

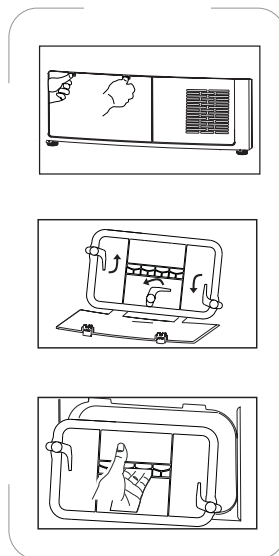



4. If necessary, clean the heat exchanger once every 2 months.



Do not touch the heat exchanger with your hand!

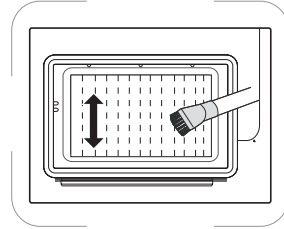

Remove the fluff from the heat exchanger using a vacuum cleaner with a dusting brush attached. Clean the heat exchanger without applying any pressure.

5. Place the filter base back into position. Fasten the 3 locks and make sure that they are secured.
6. Close the cover until a click is heard.



FR

NL

PT

EN

101





TROUBLESHOOTING

Problems	Possible Solutions
Dryer does not start.	Check the door has closed properly.
	Check the program has set.
	Check the start button is pressed.
Display is not on.	Check if the power supply works.
	Check if the mains plug is inserted.
	Check the program has set.
	Check the power button is pressed.
Degree of dryness is not reached.	Clean lint filter and heat exchanger.
	Empty container.
	Check drain hose.
	Dryer installation place is too restricted.
	Use higher drying level program.



If you cannot deal with problems by yourself and need help,

- press to turn off the appliance and unplug it.
- Contact the after-sales service.

Error Codes

Display	Cause	Solution
E32	Humidity sensor error	Please contact your local after-sales service if the error occurs.
E33	Temperature sensor error	
E82	Communication error	





PRODUCT FICHE

This tumble dryer's product fiche has been setup in conformity with EU Regulation No 392/2012.

Brand	Proline	
Model	PROHP82	
Rated capacity of cotton laundry for the standard cotton programme at full load	8 kg	
Dry type	Condenser	
Energy efficiency class ^①	A++	
Weighted annual energy consumption (AEC) ^②	235 kWh/annum	
Drying process	Automatic tumble dryer	
Energy consumption of the standard cotton programme	at full load (Edry)	1,78 kWh
	at partial load (Edry1/2)	1,01 kWh
Power consumption for the standard cotton programme at full load	off-mode (Po)	0,43 W
	left-on mode (Pl)	0,52 W
Duration of the left-on mode	10 minutes	
Standard drying programme ^③		
Weighted programme time (Tt) of the standard cotton programme at full and partial load	143 minutes	
Programme time of the standard cotton programme	at full load (Tdry)	210 minutes
	at partial load (Tdry1/2)	110 minutes
Condensation efficiency class ^④	B	
Average condensation efficiency of the standard cotton programme	at full load (Cdry)	84 %
	at partial load (Cdry1/2)	84 %
Weighted condensation efficiency (Ct) for the standard cotton programme at full and partial load	84 %	
Sound power level (weighted average value -LWA) for the standard cotton programme at full load	65 dB	
Built-in appliance Y/N	Não	

- ^① From A+++ (most efficient) to D (least efficient)
- ^② Energy consumption 235 kWh per year, based on 160 drying cycles of the standard cotton programme at full and partial load, and the consumption of the low-power modes. Actual energy consumption per cycle will depend on how the appliance is used.

FR

NL

PT

EN

103





- ③ The 'standard cotton programme' used at full and partial load is the standard drying programme to which the information in the label and fiche relates, that this programme is suitable for drying normal wet cotton laundry and that it is the most efficient programme in terms of energy consumption for cotton.
- ④ From A (most efficient) to G (least efficient)



SPECIFICATIONS

Rated voltage /frequency	220-240V~ 50Hz
Rated power	800W
Grade of waterproof	IPX4
Refrigerant	R290 / 120 g GWP: 3 CO2 - eq: 0 T

Hermetically sealed





DISPOSAL



 As a responsible retailer we care about the environment. As such we urge you to follow the correct disposal procedure for the appliance and packaging materials. This will help conserve natural resources and ensure that it is recycled in a manner that protects health and the environment.

You must dispose of this appliance and its packaging according to local laws and regulations.

Because this appliance contains electronic components, the appliance and its accessories must be disposed of separately from household waste when the appliance reaches its end of life.

Contact your local authority to learn about disposal and recycling.

The appliance should be taken to your local collection point for recycling. Some collection points accept appliance free of charge.

We apologise for any inconvenience caused by minor inconsistencies in these instructions, which may occur as a result of product improvement and development.

Etablissements Darty & fils ©,

9 Rue des Bateaux-Lavoirs, 94200 Ivry-sur-Seine, France 31/01/2024

FR

NL

PT

EN

105



FNAC DARTY

Etablissements Darty & fils ©,
9 Rue des Bateaux-Lavoirs,
94200 Ivry-sur-Seine, France

Déclaration UE de Conformité N°862023120026

EU Declaration of Conformity
EU- Conformiteitsverklaring
Declaración UE de Conformidad
Declaração UE de Conformidade

Description du produit –

SÈCHE-LINGE À POMPE À CHALEUR

Product Description:

HEAT PUMP DRYER

Productbeschrijving:

WARMTEPOMPDROGER

Descripción del producto:

MÁQUINA DE SECAR COM

Descrição do produto:

BOMBA DE CALOR



Marque –

Proline

Brand /Merk /Marca:

Référence commerciale –

PROHP82

Model number:

/Modelnummer / Numero de modelo /

Numero do modelo:

L'objet de la déclaration décrit ci-dessus est conforme à la législation d'harmonisation de l'Union applicable :

The object of the declaration described above is in conformity with the relevant Union harmonisation legislation:

Het hierboven beschreven voorwerp is in overeenstemming met de desbetreffende harmonisatiewetgeving van de Unie:

El objeto de la declaración descrita anteriormente es conforme con la legislación de armonización pertinente de la Unión:

O objeto da declaração acima descrito está em conformidade com a legislação de harmonização da União aplicável:



**Reference number**

- 2014/30/EU
- 2014/35/EU
- 2009/125/EC
- 2011/65/EU & (EU) 2015/863

Title

EMC Directive (EMC)
Low Voltage Directive (LVD)
Eco design requirements for energy-related products (ErP)
RoHS

EMC:

EN IEC 55014-1:2021
EN IEC 55014-2:2021
EN IEC 61000-3-2:2019+A1
EN 61000-3-3:2013+A1+A2

LVD :

EN 60335-1:2012+A11:2014+A13:2017+A1:2019+A14:2019+A2:2019+A15:2021
EN 60335-2-11:2010+A11:2012+A1:2015+A2:2018
EN 62233:2008

ErP :

(EU) No 932/2012
(EU) No 392/2012
EN 61121:2013+A11:2019

La présente déclaration de conformité est établie sous la seule responsabilité du fabricant.

This declaration of conformity is drawn up under the sole responsibility of the manufacturer.
Deze conformiteitsverklaring wordt uitsluitend onder de verantwoordelijkheid afgelegd van de fabrikant.
Esta declaración de conformidad se redacta bajo la exclusiva responsabilidad del fabricante.
Esta declaração de conformidade é redigida sob a responsabilidade exclusiva do fabricante.

Le responsable de cette déclaration est :

The person responsible for this declaration is:
De verantwoordelijke persoon voor deze verklaring is:
La persona responsable de esta declaración es:
A pessoa responsável por esta declaração é:



Signé par et au nom de – Signed by and on behalf of: **Etablissements Darty & Fils**
Nom – Name : **Predrag Petricevic**
Fonction – Position: **Directeur du Laboratoire Fnac Darty**

Place, Date / Lieu :
Ivry-sur-Seine, décembre 20, 2023

DocuSigned by:
Predrag Petricevic
EA30F3FB8F314D0...





PROLINE

Etablissements Darty & fils ©,
9 Rue des Bateaux-Lavoirs, 94200 Ivry-sur-Seine, France

